

TABLE OF CONTENTS

	SOLID BODY ELECTRIC GUITARS
4-5	Prestige/Premium
8-11	RG Prestige
12-13	RG Premium
14-15	RG
16	RGD Prestige
17	RGD
19	RGA Prestige
20-21	RGA
22-23	GRGA/GRG
24-25	ARZ/ART
26-27	DARKSTONE
28-29	X
30	S Prestige
31	S
32	SV Prestige
33	SA
34	GSA/GAX
35	FR
36-37	JS
38-39	JEM/UV
40-41	APEX/EGEN/STM
42-43	MTM/PGM/AT
44	ORM/NDM
	HOLLOW BODY GUITARS
45	AGR/AMF
46-47	AS
48-49	AF/AFS/AK/AG
50-51	GB/PM/JSM
	ELECTRIC BASSES
54-55	SR Prestige
56	SR Premium
57-60	SR
61	SRX
62-63	GSR
64	ATK Prestige
65	ATK/GATK
66-67	BTB/JTKB/AFB/AGB
68-71	Grooveline
72-73	GVB/GWB/K5
74-75	MDB/SDB/PIB/PGB
	PACKAGES
76-77	Jumpstart
	AMPLIFIERS
80	TSA
81	Wholetone
82-83	Tone Blaster X/IBZ/Desktop Amp
84-85	Promethean
86	Sound Wave
87	Troubadour
	EFFECTS
88-89	9 series&TS808
90	Tube King/Weeping Demon/WH10V2
91	JEMINI/AF2
	ACCESSORIES
92-93	Tuners
94-95	Cables/Straps
96-97	Picks/Guitar Stands
98-99	Bags/Cases
	OTHERS
100-101	Original Hardware (Tremolo, Bridge)
102-103	Pickup Specifications/Neck Dimensions
104	Guitar Switching Systems
105	Bass Electronics
106-107	Finishes

As the world changes, musical trends change, and the Ibanez lineup continually evolves along with these shifts. However, one constant remains: the passion and effort Ibanez puts forth to offer the best in musical instruments, suited to YOUR style and suited to where YOU are in your musical development. That's why you'll see a wide range of instruments listed in these pages. Ibanez knows that every musician is different and wants the instrument that is right for them.

If you are into heavy rock, Ibanez has the downtuned RGD series. If you prefer a single-cutaway but still need to shred, we have the 24-fret ARZ. We can also take you to even further extremes, or to the completely opposite side, like with Ibanez's huge variety of Artcore hollow body guitars.

For the more experienced player, we have the Prestige models, which offer the ultimate in Ibanez craftsmanship down to the last detail. And for those about to make a first step into this great world of music, we have a wide selection of GIO models, each of which we are proud to say offers true Ibanez quality. For 2011, we now offer the new Premium series of guitars designed for hardworking musicians. These guitars are for players who push their guitars to the fullest every night on stage and who demand real professional quality instruments both functionally and visually.

HERE ARE YOUR CHOICES ENJOY YOUR SEARCH YOU'RE SURE TO FIND YOUR IBANEZ





Prestige

PRECISION PERFORMANCE PLAYABILITY
EVERYTHING YOU'VE EVER DREAMED OF IN A GUITAR OR BASS

There are three principles behind our new Ibanez Prestige line: Precision, Performance, and Playability. The combination of high-tech manufacturing techniques with old-world Japanese craftsmanship, true innovation in design and construction, and the incorporation of ideas and suggestions from musicians from around the world are the cornerstones of the Prestige production process.



PREMIUM

PERFORMANCE BEYOND EXPECTATION

Ibanez guitars are often praised for their outstanding playability and performance. In 2011, we are proud to introduce the new "Premium" lines, delivering high-end performance and road warrior dependability, at middle-of-the-road pricing. Manufactured with select materials, dedicated skills of craftsmanship and care in details, and high-profile electronics and hardware, Ibanez Premium guitars and basses show you possibilities you could never have imagined and offer you "Performance Beyond Expectation."



ELECTRIC GUITARS

GREAT TONE STARTS WITH GREAT GEAR. SHAPE YOURS WITH IBANEZ.

RG *Prestige*

The RG is the most recognizable and distinctive guitar in the Ibanez line. Forged in the fires of 80's metal, this high-performance machine was built with speed and strength in mind. Whether using a locking tremolo with a sharp action knife edge or a hardtail bridge, the RG is a precision instrument.

DiMarzio® Pickups

The RG3250MZ, RG3570Z and RG3550MZ also feature the DiMarzio® Tone Zone™ in the bridge position, True Velvet™ in the middle position, and the Air Norton™ in the neck position. With colored bobbins, these pickups add the flair of the 80's music scene to these modern designs.



Bobby Thompson
—Job For A Cowboy



Mårten Hagström
—Meshuggah



Tony MacAlpine



Fredrik Thordendal
—Meshuggah



Dexter Holland
—The Offspring



RG4570Z VV
VV (Vintage Violin)



RG4570Z HBK
HBK (Himalayan Black)



RG3550MZ GK

- 5pc Super Wizard HP Maple/Walnut neck *Prestige* w/KTS™ TITANIUM Reinforcement
- Basswood body
- Jumbo frets
- Edge-Zero bridge w/ZPS3
- DiMarzio® Air Norton™ (H) neck pu
- DiMarzio® True Velvet™ (S) mid pu
- DiMarzio® Tone Zone® (H) bridge pu
- Hardware color : Cosmo Black
- Scale : 648mm/25.5"
- Color : GK (Galaxy Black)



RG3250MZ DY
DY (Desert Sun Yellow)

RG3250MZ

- 5pc Super Wizard HP Maple/Walnut neck *Prestige* w/KTS™ TITANIUM Reinforcement
- Basswood body
- Jumbo frets
- Edge-Zero bridge w/ZPS3
- DiMarzio® Air Norton™ (H) neck pu
- DiMarzio® True Velvet™ (S) mid pu
- DiMarzio® Tone Zone® (H) bridge pu
- Hardware color : Cosmo Black
- Scale : 648mm/25.5"
- Colors : DY (Desert Sun Yellow) / FOB (Frozen Ocean Blue)



RG3250MZ FOB
FOB (Frozen Ocean Blue)

RG3570Z LB

- 5pc Super Wizard HP Maple/Walnut neck *Prestige* w/KTS™ TITANIUM Reinforcement
- Basswood body
- Jumbo frets
- Edge-Zero bridge w/ZPS3
- DiMarzio® Air Norton™ (H) neck pu
- DiMarzio® True Velvet™ (S) mid pu
- DiMarzio® Tone Zone® (H) bridge pu
- Hardware color : Cosmo Black
- Scale : 648mm/25.5"
- Color : LB (Laser Blue)



Ultra HP Neck

Ball-milled new Ultra HP neck gives fast yet full grip feel for more versatile players – 18mm thickness at 1st fret and 20mm at the 12th.



Super Wizard HP Neck

Refined super-fast Prestige Wizard neck for ultimate shredders - 17mm thickness at 1st fret and 19mm at the 12th.





RG2570MZ CAB

- 5pc Wizard HP Maple/Walnut neck *Prestige*
- Basswood body
- Jumbo frets
- Edge-Zero bridge w/ZPS3
- DiMarzio® IBZ-N (H) neck pu
- DiMarzio® IBZ-S (S) mid pu
- DiMarzio® IBZ-B (H) bridge pu
- Hardware color : Cosmo Black
- Scale : 648mm/25.5"
- Color : CAB (Caribbean Blue Lagoon)



RG2550Z GK
GK (Galaxy Black)



RG2550Z GW
GW (Galaxy White)

FX EDGE III-8 Bridge

Ibanez FX EDGE III-8 double-locking fixed bridge was made specifically to handle and augment the awesome extended range of the RG2228GK 8-string.

EMG® 808 Pickups

The U.S.A.-made EMG® 808 active pickups-the first ever full-production 8-string pickups.



RG2550Z

- 5pc Wizard HP Maple/Walnut neck *Prestige*
- Basswood body
- Jumbo frets
- Edge-Zero bridge w/ZPS3
- DiMarzio® IBZ-N (H) neck pu
- DiMarzio® IBZ-S (S) mid pu
- DiMarzio® IBZ-B (H) bridge pu
- Hardware color : Cosmo Black
- Scale : 648mm/25.5"
- Colors : GK (Galaxy Black) / GW (Galaxy White)



RG2228 GK

- 5pc Ultra-8 Maple/Wenge neck *Prestige* w/KTS™ TITANIUM Reinforcement
- Basswood body
- Jumbo frets
- FX Edge III-8 bridge
- EMG® 808 (H) neck pu
- EMG® 808 (H) bridge pu
- Hardware color : Black
- Scale : 685.8mm/27"
- Factory Tuning: 1D#, 2A#, 3F#, 4C#, 5G#, 6D#, 7A#, 8F
- String Gauge: .009/ .011/ .016/ .024/ .032/ .042/.054/ .065
- Color : GK (Galaxy Black)

RG1527Z BK

- 5pc Wizard-7 Maple/Wenge neck *Prestige*
- Basswood body
- Jumbo frets
- Edge-Zero 7 bridge w/ZPS3
- V77 (H) neck pu
- V87 (H) bridge pu
- Hardware color : Cosmo Black
- Scale : 648mm/25.5"
- Color : BK (Black)



RG1570Z JB
JB (Jewel Blue)



RG1570Z BK
BK (Black)



RG1570Z LMR
LMR (Liquid Metal Red)



RG1550MZ BK

- 5pc Wizard HP Maple/Walnut neck *Prestige*
- Basswood body
- Jumbo frets
- Edge-Zero bridge w/ZPS3
- V7 (H) neck pu
- S1 (S) mid pu
- V8 (H) bridge pu
- Hardware color : Cosmo Black
- Scale : 648mm/25.5"
- Color : BK (Black)



RG1451 WHP
WHP (White Plaster)



RG1451 NC
NC (Night Crow)

RG1451

- 5pc Wizard HP Maple/Walnut neck *Prestige*
- Basswood body
- Jumbo frets
- Tight-End bridge
- V6F (H) neck pu
- RTS (S) mid pu
- V6F2 (H) bridge pu
- Hardware color : Cosmo Black
- Scale : 648mm/25.5"
- Colors : WHP (White Plaster) / NC (Night Crow)

V7/S1/V8 Pickup

The RG1570Z/RG1550MZ can dial in any tone, from crystal clear to searing and nasty, thanks to its V7 neck pickup, S1 middle pickup and V8 bridge pickup combination.

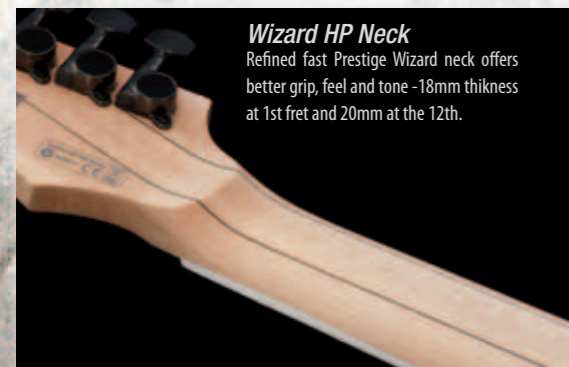

Wizard HP Neck

Refined fast Prestige Wizard neck offers better grip, feel and tone - 18mm thickness at 1st fret and 20mm at the 12th.



Edge-Zero Tremolo

The Edge-Zero has a sharp knife-edge for extremely accurate tremolo playing. This tremolo also uses Ibanez innovations to keep string action constant and the bridge surface smooth. The specially designed arm socket prevents unnecessary wobble from the arm while providing full control over the arm's torque.



Tight-End Bridge

The Tight-End bridge integrates every aspect of the bridge design in rigidness and accuracy. Saddles are firmly locked onto the base plate for maximum string vibration, and remain perfectly linear during intonation adjustment for the most accurate set up. The saddle height can be adjusted individually by one screw. Also, the top side of the bridge is smooth finished. So if you play hard, the Tight-End bridge will forgive you and your hands.



Elias Viljanen
—Sonata Arctica



Ryan Knight
—The Black Dahlia Murder



James Davies
—The Blackout



RG PREMIUM

RG models are made to be played, and played a lot. Among our various lines, the RG Premium is recognized as the ultimate workhorse guitar for today's hardworking musician. The combination of brand new Ibanez Edge-Zero II tremolo with ZPS, and elaborated craft processes, promises you perfect tuning stability and playing comfort. Also the original CAP-VM pickups specially designed for the Premium RG maximize the potential of the gear to produce the tone you desire.



RG870QMZ BI
BI (Black Ice)



RG870QMZ HVV
HVV (High Voltage Violet)



RG870QMZ RDT
RDT (Red Desert)



RG870Z BK
BK (Black)



RG870Z LB
LB (Laser Blue)

RG870QMZ

- 5pc Wizard Maple/Walnut neck w/KTS™ TITANIUM Reinforcement
- Quilted Maple top / Basswood body - Jumbo frets
- Edge-Zero II bridge w/ZPS3Fe
- CAP-VM1 (H) neck pu
- CAP-VM1S (S) mid pu
- CAP-VM2 (H) bridge pu
- Hardware color : Cosmo Black
- Scale : 648mm/25.5"
- Colors : BI (Black Ice) HVV (High Voltage Violet) RDT (Red Desert)



Edge Zero II

Installation of the zero point system in the Edge Zero II makes tuning easier and faster as well as providing stable tuning for long performances, all while maintaining smooth tremolo playing. Loss of tuning is kept to a minimum even when a string breaks. For players that prefer a full floating system, simply remove the stop bar.

RG870Z

- 5pc Wizard Maple/Walnut neck w/KTS™ TITANIUM Reinforcement
- Basswood body - Jumbo frets
- Edge-Zero II bridge w/ZPS3Fe
- CAP-VM1 (H) neck pu
- CAP-VM1S (S) mid pu
- CAP-VM2 (H) bridge pu
- Hardware color : Cosmo Black
- Scale : 648mm/25.5"
- Colors : BK (Black) LB (Laser Blue)

Premium Fret Edge Treatment

The premium fret edges are processed to be specially rounded for smooth play and comfortable neck grip.



CAP-VM1/1S/2 Pickup

RG Premium guitars produce the tone of great diversity, from pure clean to aggressive distortion sound with newly developed pickups, CAP-VM1, VM1S and VM2 which work in great combination that enables such versatile characters. Also, minimum sound loss by adopting OFC coil.

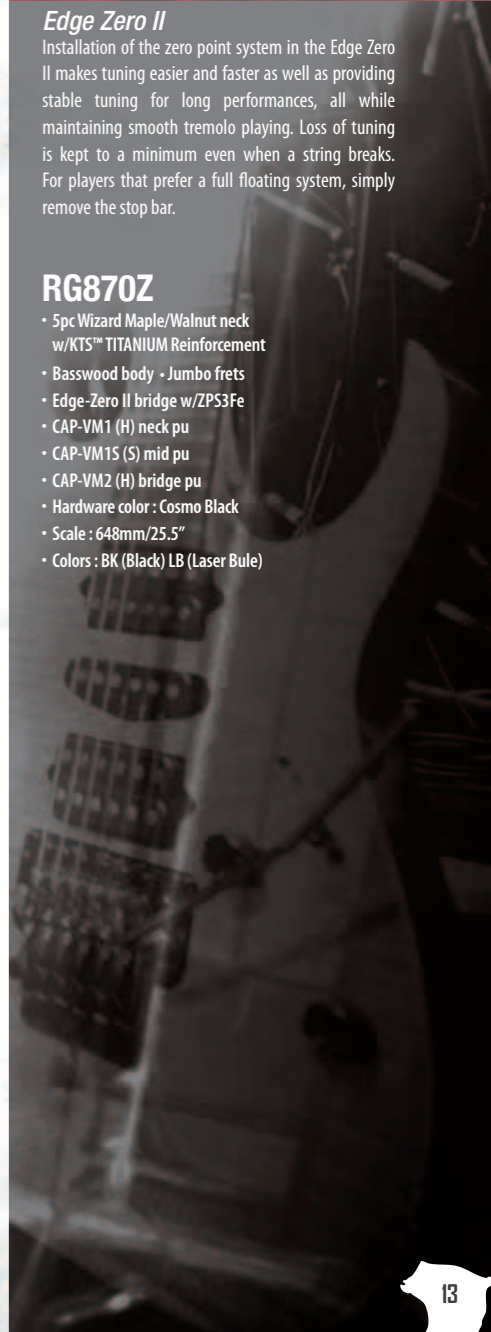

RG STANDARD

RG Tremolo models stand up to the most abusive whammy bar users around. Now featuring the Edge Zero II tremolo with the zero point system, tuning stability is maximized. Lightning fast fretboard work is no problem with the Wizard neck, flat fingerboard, and jumbo frets.

RG470AHZ NTF

- 3pc Wizard III Maple neck
- Ash body
- Jumbo frets
- Edge-Zero II bridge w/ZPS3Fe
- INF1 (H) neck pu
- INF51 (S) mid pu
- INF2 (H) bridge pu
- Hardware color : Cosmo Black
- Scale : 648mm/25.5"
- Color : NTF (Natural Flat)



Light Ash Body
RG470AH's light ash body brings more punch to the mid-range tones.



RG420FBZ NBF

- 3pc Wizard III Maple neck
- Figured Bubinga top/Mahogany body
- Jumbo frets
- Edge-Zero II bridge w/ZPS3Fe
- INF1 (H) neck pu
- INF2 (H) bridge pu
- Hardware color : Cosmo Black
- Scale : 648mm/25.5"
- Color : NBF (Natural Brown Burst Flat)



RG350EXZ BK

- 3pc Wizard III Maple neck
- Basswood body
- Jumbo frets
- Edge-Zero II bridge w/ZPS3Fe
- INF3 (H) neck pu
- INF53 (S) mid pu
- INF4 (H) bridge pu
- Hardware color : Cosmo Black
- Scale : 648mm/25.5"
- Color : BK (Black)



RG350DXZ WH

- 3pc Wizard III Maple neck
- Basswood body
- Jumbo frets
- Edge-Zero II bridge w/ZPS3Fe
- INF3 (H) neck pu
- INF53 (S) mid pu
- INF4 (H) bridge pu
- Hardware color : Black
- Scale : 648mm/25.5"
- Color : WH (White)

Edge Zero II Tremolo

Installation of the zero point system in the Edge Zero II makes tuning easier and faster as well as providing stable tuning for long performances, all while maintaining smooth tremolo playing. Loss of tuning is kept to a minimum even when a string breaks. For players that prefer a full floating system, simply remove the stop bar.



Markus Toivonen
-Ensiferum
Photo by Audrey Dujardin / Shutterblast.net



RG370DXZ BK

- 3pc Wizard III Maple neck
- Basswood body
- Jumbo frets
- Edge-Zero II bridge w/ZPS3Fe
- INF3 (H) neck pu
- INF53 (S) mid pu
- INF4 (H) bridge pu
- Hardware color : Black
- Scale : 648mm/25.5"
- Color : BK (Black)
- Also available left-handed model in BK finish (RG370DXZL BK)



RGR321EX BK

- 3pc Wizard III Maple neck
- Basswood body
- Jumbo frets
- Gibraltar Standard bridge
- INF1 (H) neck pu
- INF2 (H) bridge pu
- Hardware color : Black
- Scale : 648mm/25.5"
- Color : BK (Black)



RG350MZ

- 3pc Wizard III Maple neck
- Basswood body
- Jumbo frets
- Edge-Zero II bridge w/ZPS3Fe
- INF3 (H) neck pu
- INF53 (S) mid pu
- INF4 (H) bridge pu
- Hardware color : Black
- Scale : 648mm/25.5"
- Colors : BK (Black) / YE (Yellow)



RG350MZ YE

YE (Yellow)



RG350MZ BK

BK (Black)



Petri Lindroos
-Ensiferum
Photo by Tina Lindroos / unitedshot.com

RGD

As a pioneer of heavy rock guitars, Ibanez has released 7- and 8-string models in the past, and the RGD is Ibanez's ultimate heavy rock machine. Heavy rock guitars are required to output clear sound down to the lowest note without losing playability. So we minimized extension of the neck scale to 1-inch, and original tuned pickups are mounted. Also, RGD features the special cuts on horn and body offering ultimate playability for upper fret access.

Scoop Cut

This bold horn cut provides easy access to higher frets along with making the guitar lighter. The design feature of the horns tapering towards the tip provides stress-free playing and is a unique Ibanez idea that was developed through our artist relationships.

V7/V8 Custom Pickups

The V7/V8 Custom pickups on RGD Prestige models were specially designed and tuned for capturing more low-end, by regenerating a wider tonal range. Instead of losing the low-end, they output it with a rich, harmonic tone.



Ihsahn



Brandon Jacobs
—Mutiny Within



Ben Orum
—All Shall Perish



Jesse Ketive
—Emmure



Monte Money
—Escape The Fate



Devin Shidaker
—Oceano



RGD Prestige

RGD2120Z ISH
ISH (Invisible Shadow)

RGD2120Z CSM
CSM (Cobweb Silver Metallic)

RGD2120Z

- 5pc Wizard HP Maple/Walnut neck *Prestige* w/KTS™ TITANIUM Reinforcement
- Basswood body
- Jumbo frets
- Edge-Zero bridge w/ZPS3
- V7 Custom (H) neck pu
- V8 Custom (H) bridge pu
- Hardware color : Cosmo Black
- Scale : 672mm/26.5"
- Factory Tuning : 1D, 2A, 3F, 4C, 5G, 6D
- String gauge: .010/ .013/ .017/ .026/ .036/ .046
- Colors : ISH (Invisible Shadow) CSM (Cobweb Silver Metallic)

RGD2127Z ISH

- 5pc Wizard-7 Maple/Wenge neck *Prestige* w/KTS™ TITANIUM Reinforcement
- Basswood body
- Jumbo frets
- Edge-Zero 7 bridge w/ZPS3
- V77 Custom (H) neck pu
- V87 Custom (H) bridge pu
- Hardware color : Cosmo Black
- Scale : 672mm/26.5"
- Factory Tuning : 1D, 2A, 3F, 4C, 5G, 6D, 7A
- String gauge: .010/ .013/ .017/ .026/ .036/ .046/ .059
- Color : ISH (Invisible Shadow)



RGD STANDARD

RGD320Z BK
BK (Black)

RGD320Z WH
WH (White)

RGD7320Z BKF

- 5pc Wizard II-7 Maple/Walnut neck
- Basswood body
- Jumbo frets
- Edge-Zero II-7 bridge w/ZPS3Fe
- CAP-VK17 (H) neck pu
- CAP-VK27 (H) bridge pu
- Hardware color : Black
- Scale : 672mm/26.5"
- Factory Tuning : 1D, 2A, 3F, 4C, 5G, 6D, 7A
- String gauge: .010/ .013/ .017/ .026/ .036/ .046/ .059
- Color : BKF (Black Flat)

Edge Zero II-7 Tremolo

The Edge Zero II-7 features the same zero point system that provides speedy and stable tuning in the 6-string Edge Zero II. By installing the 7-string model's accessory reinforcement spring, playing with heavier strings is possible. Players can experience the power of heavy yet stable tremolo playing.



CAP-VK Pickups

By employing the pickup magnet strength in various ways, output at the neck is perfectly balanced with high output at the bridge. These pickups are designed to increase reverberation of lower tones, making them excellent for down tuning.



RGA

Dino Cazares
-Fear Factory



Brent Rambler
-August Burns Red



Matt Bachand
-Shadows Fall



Mark Jansen
-Epica, MaYaN



JB Brubaker
-August Burns Red



Brian Leppke
-Bleeding Through



Denis Schmidt
-Caliban



Marc Görtz
-Caliban



RGA *Prestige*

The RGA archtop guitar not only has curves but playability. And for live performance, its lightweight body gives players more freedom to move on stage. The arched top also allows players to knock down heavy riffs and power chords without hitting the guitar body. Curved beauty and great performance combine gracefully in the RGA.

RGA420Z PRT

- 5pc Wizard HP Maple/Walnut neck *Prestige*
- Flamed Maple top/Mahogany body
- Jumbo frets
- Edge-Zero bridge w/ZPS3
- CAP-LZ10 (H) neck pu
- CAP-LZ20 (H) bridge pu
- Hardware color : Cosmo Black
- Scale : 648mm/25.5"
- Color : PRT (Predator's Tongue)



RGA427Z DSH

- 5pc Wizard-7 Maple/Wenge neck *Prestige*
- Flamed Maple top/Mahogany body
- Jumbo frets
- Edge-Zero 7 bridge w/ZPS3
- LZ7 (H) neck pu
- LZ7 (H) bridge pu
- Hardware color : Cosmo Black
- Scale : 648mm/25.5"
- Color : DSH (Devil's Shadow)



RGA220Z CYW
CYW (Crystal Wine)



RGA220Z CYB
CYB (Crystal Black)

RGA220Z

- 5pc Wizard HP Maple/Walnut neck *Prestige*
- Mahogany body
- Jumbo frets
- Edge-Zero bridge w/ZPS3
- CAP-LZ10 (H) neck pu
- CAP-LZ20 (H) bridge pu
- Hardware color : Cosmo Black
- Scale : 648mm/25.5"
- Colors : CYW (Crystal Wine) / CYB (Crystal Black)



CAP-LZ10/20 Pickup

CAP-LZ10/20 are newly developed active pickups. They deliver high-power yet cut-through sound, and also minimize the noise even played with high gain setting. The CAP-LZ pickups cover very wide range, and offer strong but rich middle tone for fast and heavy riff and shred solo playing.



Special Horn Cut (RGA Prestige)

The RGA Prestige also utilizes a scoop cut on the back of the horns. This feature provides maximum access and playability at higher frets without degrading the fat tone players can achieve with an arched top. This unique shape was developed by gathering opinions from numerous Ibanez artists.



RGA

Horn & Binding (RGA72QM-TLB)

The new scoop cut utilized on the horns creates a sharper appearance along with increasing playability at the higher frets. In addition, the binding on the body gives the guitar a refined look.

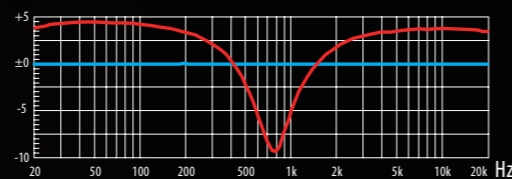

Active EQ

Specially designed to function with the fat and strong CAP-LZ 10/20 pickups, the output is controlled by an active circuit to provide pure tone free of noise.

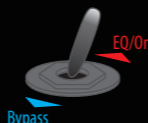

RGA72TQMZ TGB

- 3pc Wizard III Maple set-in neck w/KTS™ TITANIUM Reinforcement
- Quilted Maple top/Mahogany body
- Jumbo frets
- Edge-Zero II bridge w/ZPS3Fe
- CAP-LZ10 (H) neck pu
- CAP-LZ20 (H) bridge pu
- Hardware color : Cosmo Black
- Scale : 648mm/25.5"
- Color : TGB (Transparent Gray Burst)



RGA72QM TLB

- 3pc Wizard III Maple set-in neck w/KTS™ TITANIUM Reinforcement
- Quilted Maple top/Mahogany body
- Jumbo frets
- Gibraltar Standard bridge
- CAP-LZ10 (H) neck pu
- CAP-LZ20 (H) bridge pu
- Hardware color : Cosmo Black
- Scale : 648mm/25.5"
- Color : TLB (Transparent Lavender Burst)



RGA42TFMZ TRB

- 3pc Wizard III Maple neck
- Flamed Maple top/Mahogany body
- Jumbo frets
- Edge-Zero II bridge w/ZPS3Fe
- CAP-LZ10 (H) neck pu
- CAP-LZ20 (H) bridge pu
- Hardware color : Cosmo Black
- Scale : 648mm/25.5"
- Color : TRB (Transparent Red Burst)



RGA42 BK

- 3pc Wizard III Maple neck
- Mahogany body
- Jumbo frets
- Gibraltar Standard bridge
- CAP-LZ10 (H) neck pu
- CAP-LZ20 (H) bridge pu
- Hardware color : Cosmo Black
- Scale : 648mm/25.5"
- Color : BK (Black)



RGA32 MOL
MOL (Mahogany Oil)



RGA32 WH
WH (White)

RGA32

- 3pc Wizard III Maple neck
- Mahogany body
- Jumbo frets
- Gibraltar Standard bridge
- CAP-LZ10 (H) neck pu
- CAP-LZ20 (H) bridge pu
- Hardware color : Cosmo Black
- Scale : 648mm/25.5"
- Colors : MOL (Mahogany Oil) / WH (White)



RGA7 BK

- 5pc Wizard II-7 Maple/Walnut neck
- Mahogany body
- Jumbo frets
- Gibraltar Standard-7 bridge
- LZ7-N (H) neck pu
- LZ7-B (H) bridge pu
- Hardware color : Cosmo Black
- Scale : 648mm/25.5"
- Color : BK (Black)



RGA8 BK

- 5pc Wizard II-8 Maple/Walnut neck w/KTS™ TITANIUM Reinforcement
- Mahogany body
- Jumbo frets
- FX Edge III-8 bridge
- LZ8-N (H) neck pu
- LZ8-B (H) bridge pu
- Hardware color : Black
- Scale : 685.8mm/27"
- Color : BK (Black)



FX EDGE III-8 Bridge

Ibanez FX EDGE III-8 double-locking fixed bridge was made specifically to handle and augment the awesome extended range of the RGA8 8-string.



Gibraltar Standard Bridge

The Gibraltar Standard is a simple fixed bridge that was designed to adhere firmly to the guitar body and make good transfer of the string vibrations. It is also incredibly smooth for maximum playing comfort

GRG/GRGA

A guitar doesn't have to cost a bundle to sound good. The GIO series was developed for players who want Ibanez quality in a more affordable package. The newest addition is the GRGA42T. With an arched top, double-locking bridge, and EMG-HZ pickups, it has everything you need for in a real metal guitar.



EMG®-Hz Pickups (GRGA42T)
The GRGA42T is equipped with EMG® Hz pickups.



GRGA42T BKN

- GRGA1 Maple neck
- Mahogany body
- Medium frets
- Edge III bridge
- EMG® H4A (H) neck pu
- EMG® H4 (H) bridge pu
- Hardware color : Black
- Scale : 648mm/25.5"
- Color : BKN (Black Night)



GRG250DX BKF

- GRG2 Maple neck
- Basswood body
- Medium frets
- Edge III bridge
- PSND1 (H) neck pu
- PSNDS (S) mid pu
- PSND2 (H) bridge pu
- Hardware color : Black
- Scale : 648mm/25.5"
- Color : BKF (Black Flat)



GRG150DXB BKF

- GRG1 Maple neck
- Basswood body
- Medium frets
- Fat 10 bridge
- PSND1 (H) neck pu
- PSNDS (S) mid pu
- PSND2 (H) bridge pu
- Hardware color : Black
- Scale : 648mm/25.5"
- Color : BKF (Black Flat)



GRGR121EX BKN
BKN (Black Night)

GRGR121EX

- GRG1 Maple neck
- Basswood body
- Medium frets
- Fixed bridge
- PSND3 (H) neck pu
- PSND4 (H) bridge pu
- Hardware color : Black
- Scale : 648mm/25.5"
- Colors : BKN (Black Night) / CA (Candy Apple) / WH (White)



GRGR121EX CA
CA (Candy Apple)



GRGR121EX WH
WH (White)



GRG170DX BKN
BKN (Black Night)



GRG170DX CA
CA (Candy Apple)



GRG170DX JB
JB (Jewel Blue)



GRGM21GB BKN
BKN (Black Night)



GRGM21GB YL
YL (Yellow)



MiKro Bag

GRG270B BKN

- GRG2 Maple neck
- Basswood body
- Medium frets
- Edge III bridge
- PSND1 (H) neck pu
- PSNDS (S) mid pu
- PSND2 (H) bridge pu
- Hardware color : Black
- Scale : 648mm/25.5"
- Color : BKN (Black Night)

GRG170DX

- GRG1 Maple neck
- Basswood body
- Medium frets
- Fat 10 bridge
- PSND1 (H) neck pu
- PSNDS (S) mid pu
- PSND2 (H) bridge pu
- Hardware color : Chrome
- Scale : 648mm/25.5"
- Colors : BKN (Black Night) / CA (Candy Apple) / JB (Jewel Blue)
- Also available left-handed model in BKN finish (GRG170DXL BKN)

GRGM21GB

- GRGM Maple neck
- Poplar body
- Medium frets
- Fixed bridge
- Standard (H) neck pu
- Standard (H) bridge pu
- Hardware Color : Chrome
- Scale : 560mm/22"
- Colors : BKN (Black Night) / YL (Yellow)

ART

Simple and effective, the ART is a classic single-cutaway guitar that was built for modern metal. The mahogany body is capable of producing the warm tones of yesterday, while the active low-impedance pickups can handle massive volume levels with very little noise.

ART320 TGB
TGB (Transparent Gray Burst)



ART320 BLS
BLS (Blue Sunburst)



ART320

- ART Mahogany set-in neck
- Flamed Maple top/Mahogany body
- Medium frets
- Gibraltar III bridge
- Quik Change III tailpiece
- LZ1-N (H) neck pu
- LZ1-B (H) bridge pu
- Hardware color : Cosmo Black
- Scale : 628mm/24.75"
- Colors : TGB (Transparent Gray Burst)
BLS (Blue Sunburst)

ART120 BK
BK (Black)



ART120 WH
WH (White)



ART120 TRF
TRF (Transparent Red Flat)



GART60 BKN

- GART Maple neck
- Mahogany body
- Medium frets
- Tune-O-Matic Bridge
- STDH1 (H) neck pu
- STDH2 (H) bridge pu
- Hardware color : Chrome
- Scale : 628mm / 24.75"
- Color : BKN (Black Night)



ART120

- ART Mahogany set-in neck
- Maple top/Mahogany body
- Medium frets
- Gibraltar III bridge
- Quik Change III tailpiece
- LZ1-N (H) neck pu
- LZ1-B (H) bridge pu
- Hardware color : Chrome
- Scale : 628mm/24.75"
- Colors : BK (Black) / WH (White)
TRF (Transparent Red Flat)

Gibraltar III & Quik Change III

With the addition of the Quik Change III tailpiece, string changes are a snap on the Gibraltar III bridge. Its simple rigid design is perfect for harder playing styles.



LZ1 Pickups

Ibanez original LoZ pickups have made the active pickup sounds accessible for anyone from starters to professionals. Operated by AA batteries, which are more widely available than traditional 9V batteries.

ARZ

The 24-fret, two-octave fretboard of the ARZ takes it beyond the boundaries of traditional single-cutaway guitars. The smooth neck heel provides unrivaled playability, while the rigid Tight-Tune bridge and EMG® pickups make the ARZ ideal for today's heavy rockers, who demand both heavy riffing and shredding solos.



EMG® Pickups (ARZ)

The ARZ is equipped with an EMG® 60/81 pickup combination.

24 Frets (ARZ)

The ARZ is designed with 24 frets for more freedom in performance.



Nick Hipa
-As I Lay Dying



ARZ800 TDB
TDB (Transparent Deep Black)

Matt Roberts
-3 Doors Down



ARZ800 TDR
TDR (Transparent Deep Red)



ARZ800

- 3pc ARZ Mahogany/Maple set-in neck
- Quilted Maple top/Mahogany body
- Medium frets • Tight-Tune bridge
- Tight-Tune tailpiece
- EMG® 60 (H) neck pu
- EMG® 81 (H) bridge pu
- Hardware color : Cosmo Black
- Scale : 635mm/25"
- Colors : TDB (Transparent Deep Black)
TDR (Transparent Deep Red)

ARZ700 BK

- ARZ Mahogany set-in neck
- Mahogany body
- Medium frets
- Tight-Tune bridge
- Tight-Tune tailpiece
- EMG® 60 (H) neck pu
- EMG® 81 (H) bridge pu
- Hardware color : Chrome
- Scale : 635mm/25"
- Color : BK (Black)



Tight-Tune Bridge/Tailpiece

Solid as a rock, the Tight-Tune bridge and tailpiece were designed to lock down securely and prevent any kind of wobble or movement. Each saddle is locked into the base plate, and the bridge is anchored by stud bolts into the body of the guitar. Furthermore, the studs are also locked onto the base plate so that the maximum vibration from the string is transferred to the body.





Isaac Delahaye
–*Epica*, *MaYaN*

Photo by Audrey Dujardin / Shutterstock.net



Christoph Siemons
–*Krypteria*
Photo by Tim Tronckoe



Rikard Sundén
–*Sabaton*

Photo by davidsfoto.se



Nightmare Industries
–*Deathstars*



Cat Casino
–*Deathstars*



Barry Stock
–*Three Days Grace*

DARKSTONE

The DN is the new standard in heavy metal rock guitar. As its “Darkstone” series name suggests, strong construction and smart body style combine for a powerful, clean sound. The Tight-Tune Bridge is sturdy and resonant, and the tailpiece comes equipped with the Ball-End Stopper for more lock-in on strings – both are features originally designed by Ibanez.



DN520K SSB
SSB (Silver Stream Burst)



DN520K DTV
DTV (Dark Night Violet)



DN500 BK
BK (Black)



DN500 WH
WH (White)

Tight-Tune Bridge/Tailpiece

Solid as a rock, the Tight-Tune bridge and tailpiece were designed to lock down securely and prevent any kind of wobble or movement.

Each saddle is locked into the base plate, and the bridge is anchored by stud bolts into the body of the guitar. Furthermore, the studs are also locked onto the base plate so that the maximum vibration from the string is transferred to the body.

DN520K

- DN Sapele set-in neck
- Sapele body
- Medium frets
- Tight-Tune bridge
- Tight-Tune tailpiece
- CAP-PP1-N (H) neck pu
- CAP-PP1-B (H) bridge pu
- Hardware color : Cosmo Black
- Scale : 628mm/24.75"
- Colors : SSB (Silver Stream Burst)
DTV (Dark Night Violet)

DN500

- DN Sapele set-in neck
- Sapele body
- Medium frets
- Tight-Tune bridge
- Tight-Tune tailpiece
- CAP-PP1-N (H) neck pu
- CAP-PP1-B (H) bridge pu
- Hardware color : Chrome
- Scale : 628mm/24.75"
- Colors : BK (Black)
WH (White)

Pickup Mounting Ring

The original pickup mounting ring, specially designed for the Darkstone, keeps the pickup parallel to the strings at all times. Unlike the usual mounting rings, this one enables the pickups to catch equal vibrations from each string and avoid tone loss.

Set-In Neck Construction

Set-In Neck construction on the DN-series provides massive sustain and playing comfort.



CAP-PP1 Pickups

The tube pole-piece construction of the new pickups designed for the Ibanez Darkstone offers quick response, sparkling clarity and added harmonics for a humbucker sound.

XP/IC/DT

The off-the-wall shapes of the X series stand out in a crowd, but they are also excellent examples of form meeting function. With its fast neck and tremolo system, the XPT Xiphos was made for the extreme shred player. The ICT Iceman is great for hard rock, where thick tones are literally beaten out of the guitar. The DTT Destroyer is a high gain animal, cutting through the densest forests of fuzz and distortion.



27 fret
The XPT700XH joins its shred-friendly features, such as 27 frets for full access to the upper frets, with the same exact placement of the neck pickup used on the other Xiphos guitars using the Air Norton 5™.



Eyal Levi
-Daath



Oli Herbert
-All That Remains



Tom G. Warrior
-Triptykon

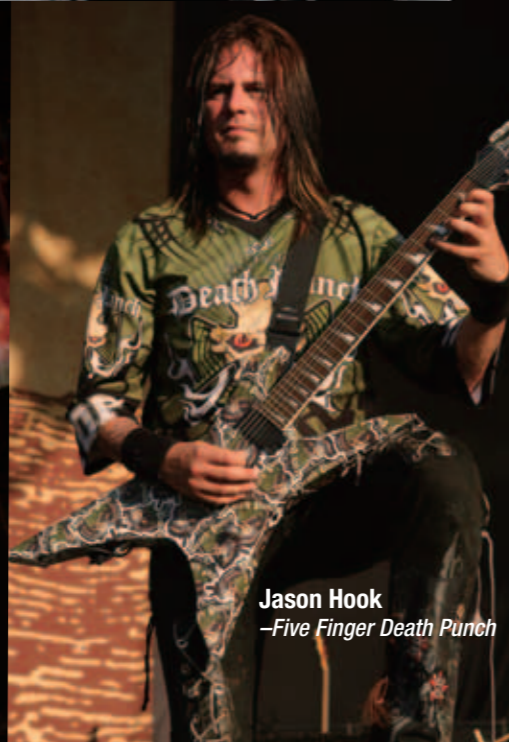

Jason Hook
-Five Finger Death Punch



Muhammed Suicmez
-Necrophagist



XPT700 BK

- 5pc Wizard III Maple/Walnut neck-thru w/KTS™ TITANIUM Reinforcement
- Mahogany wing body
- Jumbo frets
- Edge III bridge
- DiMarzio® D Activator™ (H) neck pu
- DiMarzio® D Activator™ (H) bridge pu
- Hardware color : Cosmo Black
- Scale : 648mm/25.5"
- Color : BK (Black)

XPT700XH GSF

- 5pc Wizard III Maple/Walnut neck-thru w/KTS™ TITANIUM Reinforcement
- Mahogany wing body
- Jumbo frets
- Edge III bridge
- DiMarzio® Air Norton 5™ (H) neck pu
- DiMarzio® D Activator™ (H) bridge pu
- Hardware color : Black
- Scale : 648mm/25.5"
- Color : GSF (Green Shadow Flat)

XP300FX BK

- 3pc Wizard III Maple neck
- Mahogany body
- Jumbo frets
- Fixed bridge
- INF3 (H) neck pu
- INF4 (H) bridge pu
- Hardware color : Cosmo Black
- Scale : 648mm/25.5"
- Color : BK (Black)

ICT700 BK

- 5pc Wizard III Maple/Walnut neck-thru w/KTS™ TITANIUM Reinforcement
- Mahogany wing body
- Jumbo frets
- Gibraltar Custom bridge
- DiMarzio® D Activator™ (H) neck pu
- DiMarzio® D Activator™ (H) bridge pu
- Hardware color : Black
- Scale : 648mm/25.5"
- Color : BK (Black)

DTT700 MGS

- 5pc Wizard III Maple/Walnut neck-thru w/KTS™ TITANIUM Reinforcement
- Mahogany wing body
- Jumbo frets
- Gibraltar Custom bridge
- DiMarzio® D Activator-X™ (H) neck pu
- DiMarzio® D Activator-X™ (H) bridge pu
- Hardware color : Chrome
- Scale : 648mm/25.5"
- Color : MGS (Metallic Gray Sunburst)

D Activator™
DiMarzio® D Activator™ mounted on ICT700

DiMarzio® D Activator-X™
DiMarzio® D Activator-X™ pickups combine extreme power and clarity through the use of specially tuned coils.

Neck Thru construction

Neck-thru construction on the XPT700/XPT700XH/DTT700/ICT700 provides massive sustain and playing comfort.



ZR-2 & ZPS3

The ZR-2 is a revolutionary tremolo system. It plays incredibly smooth through the use of its ball bearing mechanism. This also keeps the string action constant, even during the most rigorous tremolo use. The top side features a smooth finish for total hand comfort, and the tremolo arm snaps in for quick setup.

The ZPS3 is the next stage of zero point systems. Made of lightweight Duralumin, the addition of two outer springs makes the guitar easier to tune and provides much greater tuning stability. In fact, the other strings will stay in tune even if you break a string. If you prefer a full floating tremolo setup, simply remove the stop bar.

S Prestige

The S Prestige is "Made in Japan" by the finest Ibanez craftsmen and from top-of-the-line components. This beautifully contoured shape, combined with the ZR-2 tremolo system, produces warm, resonant tones from a super thin mahogany body.

**S5470F BH**
BH (Black Haze)**S5470F**

- 5pc Super Wizard HP Maple/Walnut neck *Prestige* w/KTS™ TITANIUM Reinforcement
- Flamed Maple top/Mahogany body
- Jumbo frets
- ZR-2 bridge w/ZPS3
- HGD1 (H) neck pu • ST2 (S) middle pu • HGD2 (H) bridge pu
- Hardware color : Cosmo Black
- Scale : 648mm/25.5"
- Colors : BH (Black Haze) / RVK (Red Viking)

**S5470F RVK**
RVK (Red Viking)**S5470Q WCB**

- 5pc Super Wizard HP Maple/Walnut neck *Prestige* w/KTS™ TITANIUM Reinforcement
- Quilted Maple top/Mahogany body
- Jumbo frets
- ZR-2 bridge w/ZPS3
- HGD1 (H) neck pu • ST2 (S) middle pu • HGD2 (H) bridge pu
- Hardware color : Cosmo Black
- Scale : 648mm/25.5"
- Color : WCB (Wild Cherry Blossom)

**HGD & ST Pickups**

The Hot Grinder pickups are specially designed for the S Prestige to output extra volume, yet sharpness is not sacrificed.

The new Short Tracer pickup matches perfectly with the hot humbuckers to give versatility on the S guitars and to produce even the most delicate tones.

**Ken Susi**
—Ueartth**Oskar Montelius**
—Sabaton
Photo by davidsfoto.se

The Ibanez S series first appeared in 1987. Ever since, it has changed in appearance and function to represent the cutting edge of Ibanez design. Famous for its lightweight carved mahogany body, the S can take a beating while still providing the resonance of guitars twice its size. The S series comes equipped with the ZR tremolo system, featuring a smooth ball bearing pivot for ultra-smooth arm control—same as ZR-2 tremolo system.

**S770FM ATF**

- 3pc Wizard III Maple neck
- Flamed Maple top/Mahogany body
- Jumbo frets
- ZR bridge w/ZPS2
- INF1 (H) neck pu • INF51 (S) mid pu • INF2 (H) bridge pu
- Hardware color : Cosmo Black
- Scale : 648mm/25.5"
- Color : ATF (Antique Burst Flat)

**S570 BK**

- 3pc Wizard III Maple neck
- Mahogany body
- Jumbo frets
- ZR bridge w/ZPS2
- INF1 (H) neck pu • INF51 (S) mid pu • INF2 (H) bridge pu
- Hardware color : Cosmo Black
- Scale : 648mm/25.5"
- Color : BK (Black)

**S570B WH**

- 3pc Wizard III Maple neck
- Mahogany body
- Jumbo frets
- ZR bridge w/ZPS2
- INF1 (H) neck pu • INF51 (S) mid pu • INF2 (H) bridge pu
- Hardware color : Black
- Scale : 648mm/25.5"
- Color : WH (White)

**S420 WK**
WK (Weathered Black)**S420 BBS**
BBS (Blackberry Sunburst)**Steve Jones**
—The Faceless**Luke Hoskin**
—Protest The Hero**S420**

- 3pc Wizard III Maple neck
- Mahogany body
- Jumbo frets
- ZR bridge w/ZPS2
- INF1 (H) neck pu
- INF2 (H) bridge pu
- Hardware color : Cosmo Black
- Scale : 648mm/25.5"
- Colors : WK (Weathered Black)
BBS (Blackberry Sunburst)

S7420 BK

- 3pc Wizard II-7 Maple neck
- Mahogany body
- Jumbo frets
- ZR-7 bridge w/ZPS2
- AH1-7 (H) neck pu
- AH2-7 (H) bridge pu
- Hardware color : Cosmo Black
- Scale : 648mm/25.5"
- Color : BK (Black)



SV *Prestige*

The S series has long been admired for its design, but some players prefer the simplicity of a non-locking tremolo. The SV was created to satisfy the professional player who wants a more versatile solution. The SynchroniZR non-locking tremolo uses the same smooth ball bearing mechanisms that have made the ZR bridge so popular. The SV also comes equipped with the True-Duo pickup system for superior tonal variety from the single coil and humbucker universe.

Rob Daniels
Photo by Roland Woodworth



Josh Rand
—Stone Sour
Photo by Michael Johansson



SV5470F NBL

- 5pc Wizard HP Maple/Walnut neck *Prestige*
- Flamed Maple top/Mahogany body
- Jumbo frets
- SynchroniZR bridge w/ZPS-FX
- TDB2 (H) neck pu • ST2 (S) mid pu • TDB3 (H) bridge pu
- Hardware color : Cosmo Black
- Scale : 648mm/25.5"
- Color : NBL (Natural Blue)

SV5470A BKD

- 5pc Wizard HP Maple/Walnut neck *Prestige*
- Ash top/Mahogany body
- Jumbo frets
- SynchroniZR bridge w/ZPS-FX
- TDB2 (H) neck pu • ST2 (S) mid pu • TDB3 (H) bridge pu
- Hardware color : Cosmo Black
- Scale : 648mm/25.5"
- Color : BKD (Black Blond)

SV5470 BK

- 5pc Wizard HP Maple/Walnut neck *Prestige*
- Mahogany body
- Jumbo frets
- SynchroniZR bridge w/ZPS-FX
- TDB2 (H) neck pu • ST2 (S) mid pu • TDB3 (H) bridge pu
- Hardware color : Cosmo Black
- Scale : 648mm/25.5"
- Color : BK (Black)

Auto Trim Tuner

Smart design cuts the excess string after you restring and tune up — no extra cutting tool needed!



Graphtech® Nut

The Graphtech® nut on the SV models offers ultimately low friction to keep you in tune and gives clearer sound and sustain.

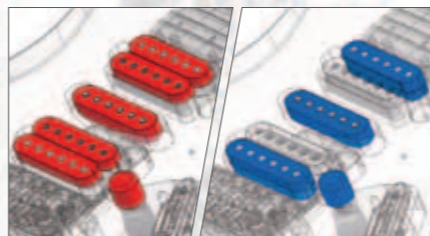

True-Duo

The unique formula of the True-Duo system, the combination of Alnico and Ferrite, stacked coils and bar magnet, has answered the conflicting demand for one guitar. In the SSS setting, it outputs glassy and clear single coil sound, not like a coil tap does, while the HSH setting packs a beefy punch, by simply pushing/pulling the volume knob.

SA

You want versatility? The SA adapts to any genre of music for clean rhythm, crunchy blues or even hard-driving riffs and solos. It also offers a variety of looks, such as metal-like solid color or traditional wooden finishes. The SA also makes use of the same True-Duo pickup system available on the SV models and the abundant resonance of the SAT-Pro tremolo.



SA260FM AMB
AMB (Amber Burst)

SA260FM TLB
TLB (Transparent Lavender Burst)

SAS36FM TRS

- 3pc SAS Maple set-in neck
- Flamed Maple top/Mahogany body
- Medium frets
- SAT Pro II bridge
- AHS1 (S) neck pu • AHS2 (S) mid pu • TDB1 (H) bridge pu
- Hardware color : Chrome
- Scale : 648mm/25.5"
- Color : TRS (Transparent Red Sunburst)

SAS36QM CBS

- 3pc SAS Maple set-in neck
- Quilted Maple top/Mahogany body
- Medium frets
- SAT Pro II bridge
- AHS1 (S) neck pu • AHS2 (S) mid pu • TDB1 (H) bridge pu
- Hardware color : Chrome
- Scale : 648mm/25.5"
- Color : CBS (Cornflower Blue Sunburst)

SA260FM

- 3pc SA Maple neck
- Flamed Maple top/Mahogany body
- Medium frets
- SAT Pro II bridge
- AHS1 (S) neck pu • AHS2 (S) mid pu
- True Duo Buckler (H) bridge pu
- Hardware color : Chrome
- Scale : 648mm/25.5"
- Colors : AMB (Amber Burst)
TLB (Transparent Lavender Burst)
- Also available left-handed model in BK finish (SA260FML-TLB)

Sat Pro II Tremolo

The Sat Pro II eliminates unnecessary resonance around the saddles by firmly securing them to the bridge plate. This keeps the saddles very stable even during frequent tremolo use.



Set-In Neck construction

SAS set-in neck features strong 3pc construction and special neck finish for extraordinary comfort and playability.



Larry Mitchell

GSA/GAX



GSA60 BKN
BKN (Black Night)



GSA60 BS
BS (Brown Sunburst)



GSA60 WH
WH (White)

GSA60

- GSA Maple neck • Agathis body
- Medium frets • SAT10 bridge
- PSNDS (S) neck pu
- PSNDS (S) mid pu
- PSND2 (H) bridge pu
- Hardware color : Chrome
- Scale : 648mm/25.5"
- Colors : BKN (Black Night)
BS (Brown Sunburst)
WH (White)



GAX30 BKN
BKN (Black Night)



GAX30 TR
TR (Transparent Red)

GAX30

- GAX1 Maple neck • Agathis body
- Medium frets • Fixed bridge
- PSND1 (H) neck pu
- PSND2 (H) bridge pu
- Hardware color : Chrome
- Scale : 628mm/24.75"
- Colors : BKN (Black Night)
TR (Transparent Red)

FR

With a simple and uncompromising design, the FR is a chameleon when it comes to musical genres. The ash body brings more punch to the midrange tones, while the Tight-End bridge provides maximum string vibration and playing comfort.



Mike Reynolds
–For Today
Photo by Shane Monahan



Andreas Mäser
–The Sorrow

Stefan Keller
–Neera



Tobias Buck
–Neera



CAP-CCR Pickups
The Ibanez original CAP-CCR pickups don't have the same heat of ceramic magnets, but still have the power to cut through the mix.



FR2620 DBS
DBS (Dark Brown Sunburst)



FR2620 NT
NT (Natural)

FR2620

- 5pc Wizard HP Maple/Walnut neck *Prestige*
- Ash body
- Jumbo frets
- Tight-End bridge
- CAP-CCR1 (H) neck pu
- CAP-CCR2 (H) bridge pu
- Hardware color : Chrome
- Scale : 648mm/25.5"
- Colors : DBS (Dark Brown Sunburst) / NT (Natural)



FR1620 BK

- 5pc Wizard HP Maple/Walnut neck *Prestige*
- Ash body
- Jumbo frets
- Tight-End bridge
- CAP-CCR1 (H) neck pu
- CAP-CCR2 (H) bridge pu
- Hardware color : Chrome
- Scale : 648mm/25.5"
- Color : BK (Black)

Tight End

The Tight-End bridge integrates every aspect of the bridge design in rigidness and accuracy. Saddles are firmly locked onto the base plate for maximum string vibration, and remain perfectly linear during intonation adjustment for the most accurate set up. The saddle height can be adjusted individually by one screw. Also, the top side of the bridge is smooth finished. So if you play hard, the Tight-End bridge will forgive you and your hands.

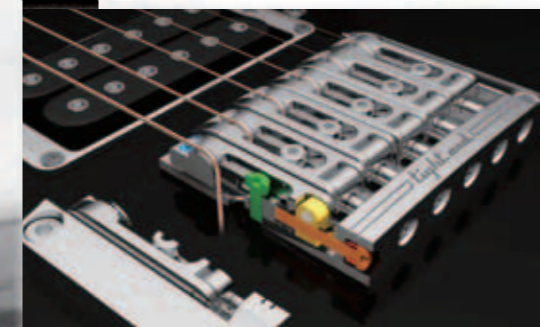

Gizz Butt
–The More I See



Photo by Neil Zlozower

**JS2400 WH**

- 1pc JS Maple neck *Prestige*
- Basswood body
- W/6105 frets
- Edge bridge
- DiMarzio® Pro Track™ (H) neck pu
- DiMarzio® Mo' Joe™ (H) bridge pu
- Hardware color : Chrome
- Scale : 648mm/25.5"
- Color : WH (White)

**JS1200 CA**

- 1pc JS Maple neck *Prestige*
- Basswood body
- W/6105 frets
- Edge bridge
- DiMarzio® Paf Joe™ (H) neck pu
- DiMarzio® Fred® (H) bridge pu
- Hardware color : Chrome
- Scale : 648mm/25.5"
- Color : CA (Candy Apple)

**JS1000 BP**

- 1pc JS Maple neck *Prestige*
- Basswood body
- W/6105 frets
- Edge bridge
- DiMarzio® Paf Pro® (H) neck pu
- DiMarzio® Fred® (H) bridge pu
- Hardware color : Cosmo Black
- Scale : 648mm/25.5"
- Color : BP (Black Pearl)

JOE SATRIANI SIGNATURE MODELS

Maestro Joe Satriani's jaw-dropping skill on the guitar is only matched by the sheer beauty and artistry of his Signature instruments. Created in collaboration with Satch himself, these models are indeed an extension of his playing: finely nuanced yet capable of staggering heights of musicality.



JS100 BK
BK (Black)

JS100

- 1pc JS Maple neck
- Basswood body
- Large frets
- Edge III bridge
- AH1 (H) neck pu
- AH2 (H) bridge pu
- Hardware color : Chrome
- Scale : 648mm/25.5"
- Colors : BK (Black)
TR (Transparent Red)



JS100 TR
TR (Transparent Red)

DiMarzio® Pickups & 24 fret

The first 24-fret fingerboard JS model is Joe Satriani's newest adventure in guitars and includes his favorite DiMarzio® pickups.



STEVE VAI

SIGNATURE MODELS

Steve Vai is one of the few guitarists universally acknowledged as one who has changed the way musicians think about what a guitar can really do. His signature Ibanez guitars are no different: Iconic, Sublime, Awe-Inspiring, Outrageous. The Ibanez JEM Series models are trailblazers in a world of imitators – there's nothing like them.

JEM77-FP2 Floral Pattern
The JEM77 features an iconic Ibanez floral pattern throughout its basswood body.



Photo by Meeno Peluce



JEM77 FP2

- 5pc JEM Maple/Walnut neck *Prestige*
- Basswood body • W/6105 frets • Edge bridge
- DiMarzio® Evolution® (H) neck pu
- DiMarzio® Evolution® (S) mid pu
- DiMarzio® Evo2™ (H) bridge pu
- Hardware color : Chrome
- Scale : 648mm/25.5"
- Color : FP2 (Floral Pattern 2)



JEM7V WH

- 5pc JEM Maple/Walnut neck *Prestige*
- Alder body • W/6105 frets • Edge bridge
- DiMarzio® Evolution® (H) neck pu
- DiMarzio® Evolution® (S) mid pu
- DiMarzio® Evolution® (H) bridge pu
- Hardware color : Gold
- Scale : 648mm/25.5"
- Color : WH (White)



JEM77V BK

- 5pc JEM Maple/Walnut neck *Prestige*
- Basswood body • W/6105 frets • Edge bridge
- DiMarzio® Breed™ (H) neck pu
- DiMarzio® Breed™ (S) mid pu
- DiMarzio® Breed™ (H) bridge pu
- Hardware color : Chrome
- Scale : 648mm/25.5"
- Color : BK (Black)



JEM505 BK
BK (Black)



JEM505 WH
WH (White)

JEM505

- 5pc JEM Maple/Walnut neck *Prestige*
- Basswood body
- W/6105 frets
- Edge bridge
- V7 (H) neck pu
- S1 (S) mid pu
- V8 (H) bridge pu
- Hardware color : Cosmo Black
- Scale : 648mm/25.5"
- Colors : BK (Black)
WH (White)



JEM555 WH

- 3pc Wizard II Maple neck
- Basswood body
- Jumbo frets
- Edge III bridge
- DiMarzio® Evolution® (H) neck pu
- DiMarzio® Evolution® (S) mid pu
- DiMarzio® Evolution® (H) bridge pu
- Hardware color : Cosmo Black
- Scale : 648mm/25.5"
- Color : WH (White)



UV777P BK

- 5pc UV Maple/Wenge neck *Prestige*
- Basswood body
- Jumbo frets
- Lo-Pro Edge 7 bridge
- DiMarzio® Blaze™ (H) neck pu
- DiMarzio® Blaze™ (S) mid pu
- DiMarzio® Blaze™ (H) bridge pu
- Hardware color : Chrome
- Scale : 648mm/25.5"
- Color : BK (Black)



Photo by Sebastien Paquet

HERMAN LI SIGNATURE MODELS

When DragonForce guitarist Herman Li wanted a guitar that could handle his otherworldly technique and musicality, both he and Ibanez knew it would take time to get everything just right. It took three years, but they did get it right. The Ibanez E-Gen is played by Li exactly as it is, live on stage, in the studio, right off the shelf, without any modifications.

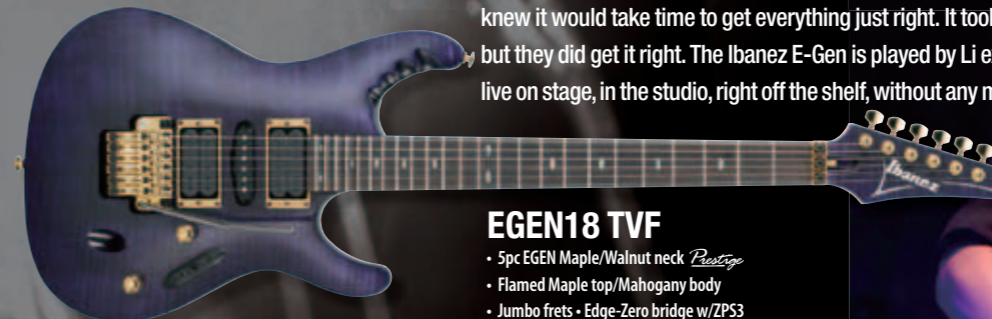

EGEN18 TVF

- 5pc EGEN Maple/Walnut neck *Prestige*
- Flamed Maple top/Mahogany body
- Jumbo frets • Edge-Zero bridge w/ZPS3
- DiMarzio® HLM (H) neck pu
- DiMarzio® HLM (S) mid pu
- DiMarzio® HLM (H) bridge pu
- Hardware color : Gold • Scale : 648mm/25.5"
- Color : TVF (Transparent Violet Flat)



EGEN8 PLB

- 3pc Wizard III Maple neck
- Flamed Maple top/Mahogany body • Jumbo frets
- Edge III bridge (Herman Li Special)
- V7 (H) neck pu • S1 (S) mid pu • V8 (H) bridge pu
- Hardware color : Gold
- Scale : 648mm/25.5"
- Color : PLB (Platinum Blonde)



Deeper Cut Horn

Modeled using Herman's hand. EGEN's unique scoop cutaway at the back of the body, allows even easier access to high frets from all angles.



Scalloped Fingerboard

The scalloped fingerboard on the upper frets is Herman Li's own touch, for easier high note bending and tapping.



MUNKY SIGNATURE MODELS

With Korn, Munky took a 7-seven string shred machine and turned it into a lowend bone crusher. His signature beast, The APEX, enters 2011 with a new look featuring a stunning sunburst finish and classic white pickguard.



DiMarzio® Blaze™ Pickups (for APEX100)
The APEX100 features DiMarzio® Blaze™ pickups. The bass-heavy response of these pickups provides maximum impact for the heaviness of the 7th string while still maintaining the ability of mid-range sounds to cut through.



APEX100 TFB

- 5pc APEX Maple/Wenge neck *Prestige*
- Alder body
- Jumbo frets
- Lo-Pro Edge 7 bridge w/U-bar
- DiMarzio® Blaze™ (S) neck pu
- DiMarzio® Blaze™ (H) bridge pu
- Hardware color : Powdered Cosmo Black
- Scale : 648mm/25.5"
- Factory tuning : 1D, 2A, 3F, 4C, 5G, 6D, 7A
- String gauge: .010/.013/.017/.030/.042/.052/.060
- Color : TFB (Tri Fade Burst)



APEX2 GSF

- 5pc APEX2 Maple/Walnut neck
- Mahogany body
- Jumbo frets
- Tone Pros® 7 bridge
- DiMarzio® Paf 7™ (H) neck pu
- DiMarzio® Paf 7™ (H) bridge pu
- Hardware color : Powdered Cosmo Black
- Scale : 648mm/25.5"
- Factory tuning : 1D, 2A, 3F, 4C, 5G, 6D, 7A
- String gauge: .010/.013/.017/.026/.036/.046/.054
- Color : GSF (Green Shadow Flat)

Photo by Sebastien Paquet

SAM TOTMAN SIGNATURE MODEL

Few guitarists have the shred skills and unshakable nerve like DragonForce's Sam Totman. Sam's Signature Iceman-shaped STM2SPB is a 24-fret mahogany monster made for only the strongest of metal warriors.

STM2 SPB

- 5pc Wizard III Maple/Walnut neck-thru w/KTS™ TITANIUM Reinforcement
- Flamed Maple top/Mahogany wing body
- Jumbo frets • Edge III bridge
- DiMarzio® EVOLUTION® (H) neck pu
- DiMarzio® EVOLUTION® (H) bridge pu
- Hardware color : Chrome
- Scale : 648mm/25.5"
- Color : SPB (Sapphire Blue)



Photo by Paul Harries



Photo by Scott Uchida

**Seymour Duncan® Blackouts™ Pickups**

MTM1 rattles the walls with high-output Seymour Duncan® Blackouts™ EMTY™ active pickups, at neck and bridge locales.

**Painted Neck**

The MTM2 comes with a matching color neck back.

**MTM1 BR**

- 5pc Wizard III Maple/Walnut neck-thru w/KTS™ TITANIUM Reinforcement
- Mahogany wing body • Jumbo frets
- FX Lo-Pro Edge bridge
- Seymour Duncan® Blackouts™ EMTY™ (H) neck pu
- Seymour Duncan® Blackouts™ EMTY™ (H) bridge pu
- Hardware color: Black
- Scale: 648mm/25.5"
- Factory Tuning: 1C#, 2G#, 3E, 4B, 5F#, 6B
- String gauge: .011/.014/.018/.028/.038/.049
- Color: BR (Blood Red)

Slipknot

MICK THOMSON

SIGNATURE MODELS

That tightness around your throat. Getting harder to breathe. Slipknot guitarist Mick Thomson's signature models have a way of doing that. With their high-output Seymour Duncan® Blackouts™ EMTY™ active pickups and Edge FX bridges, these low-tuned axes churn out demonic metal so unholy, it might make some people uncomfortable. In a good way.



MTM2 WH
WH (White)

MTM2 BK
BK (Black)

MTM2

- 5pc Wizard III Maple/Walnut neck
- Mahogany body • Jumbo frets • FX Edge III bridge
- Duncan® HB-105MT (H) neck pu
- Duncan® HB-105MT (H) bridge pu
- Hardware color: Black
- Scale: 648mm/25.5"
- Factory Tuning: 1C#, 2G#, 3E, 4B, 5F#, 6B
- String gauge: .011/.014/.018/.028/.038/.049
- Colors: BK (Black)
WH (White)



Photo by Larry DiMarzio

PAUL GILBERT

SIGNATURE MODEL

Paul Gilbert thrashes and rolls only with the best of instruments, namely his own. His signature PGM401 delivers with a rough and tumble combination of shred playability and warm tone just where you want it.

MR. BIG

**PGM401 TFB**

- 5pc PGM Maple/Walnut neck *Prestige*
- Ash body
- Medium frets
- Fixed bridge
- DiMarzio® Air Classic™ (H) neck pu
- DiMarzio® Air Classic™ (H) bridge pu
- Hardware color: Cosmo Black
- Scale: 648mm/25.5"
- Color: TFB (Tri Fade Burst)

ANDY TIMMONS

SIGNATURE MODEL

This multi-purpose axe has tone to spare, clean looks, and a configuration of DiMarzio® pickups bound to make any guitarist's playing sparkle.

**AT100CL / DiMarzio® AT-1™ Pickup**

The AT-1™ bridge pickup was specially designed and wound by DiMarzio® for Andy Timmons

**AT100CL SB**

- 1pc AT Maple neck
- Alder body • Jumbo frets
- Wilkinson® Gotoh® VSVG bridge
- DiMarzio® Cruiser™ (H) neck pu
- DiMarzio® Cruiser™ (H) mid pu
- DiMarzio® AT-1™ (H) bridge pu
- Hardware color: Chrome
- Scale: 648mm/25.5"
- SPERZEL™ machineheads
- Color: SB (Sunburst)

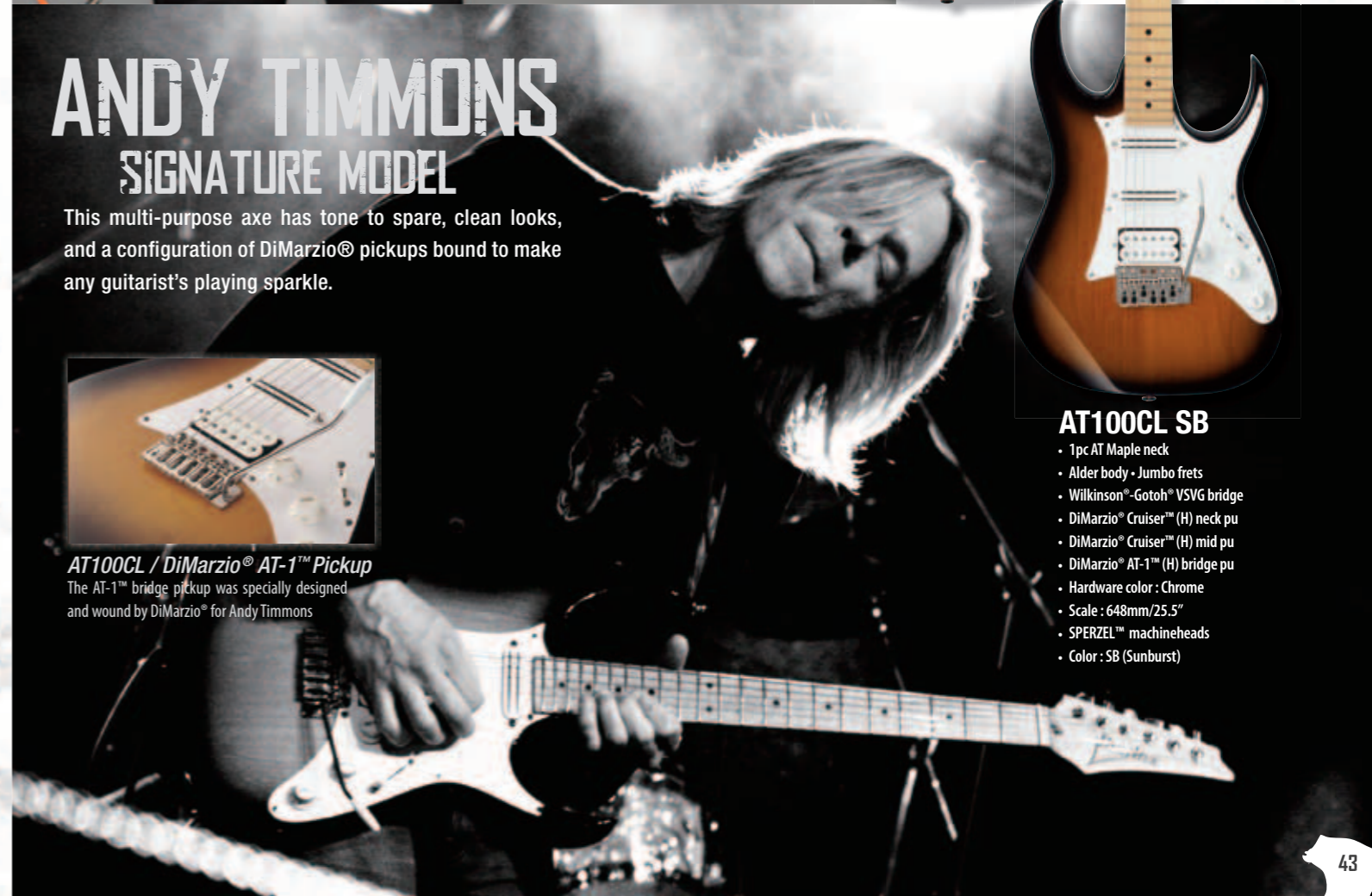



THE MARS VOLTA

OMAR RODRIGUEZ-LOPEZ SIGNATURE MODEL

Created with traditional looks in mind, this guitar had to excel in just about any situation to work in The Mars Volta. If anyone knows how to push a guitar to its limits, it's Omar Rodriguez-Lopez. The white finish ORM1WH passes every test.

Photo by Alex Solca

ORM1 WH

- 3pc ORM Mahogany neck
- Mahogany body • Medium frets
- Gibraltar III bridge
- ACH-BL (H) bridge pu
- Hardware color : Chrome
- Scale : 610mm/24.0"
- Color : WH (White)
- Left hand model also available



THE OFFSPRING NOODLES SIGNATURE MODEL

Born from punk rock attitude but built for all things aggressive. The NDM's mirrored skull Offspring emblem says it all – Flaming Death or Glory! Noodles' Signature NDM2BK is an all-purpose rock axe that can fit into any mix.

NDM2 BK

- 3pc NDM Maple neck
- Basswood body • Large frets
- Fixed bridge
- INF1 (H) neck pu • INF1 (S) mid pu • INF2 (H) bridge pu
- Hardware color : Chrome
- Scale : 648mm/25.5"
- Color : BK (Black)



SIGNATURE MODELS

AGR/AMF SERIES

AGR

AGR Slim Body

The AGR features a slender body that is slimmer than the regular Artcore body. This makes it easy to handle and gives off more of a rock feeling during performance. (The pickguard, f-holes, and pickups also give these guitars an exquisite appearance.)

The newest addition to the Artcore series, the AGR has a shallower body than the AG series, but still retains the big-sounding full-hollow body. The shiny look of the body makes the AGR perfect for dynamic stage performance.



AGR70 BK

- Artcore Mahogany set-in neck
- Maple top/back/sides • Medium frets
- ART-1 bridge • VT60 tailpiece
- ACH1-M (H) neck pu • ACH2-M (H) bridge pu
- Hardware color : Chrome
- Scale : 628mm/24.75"
- Depth: 50mm at tail
- Color : BK (Black)

AGR73T TSW

- Artcore Mahogany set-in neck
- Maple top/back/sides • Medium frets
- ART-1 bridge • VBF70 vibrato
- ACH3-M (H) neck pu • ACH4-M (H) bridge pu
- Hardware color : Gold
- Scale : 628mm/24.75"
- Depth: 50mm at tail
- Color : TSW (Twinkle Snow)

AMF

With semi-hollow, flat-top bodies and even chicken head knobs, AMF models have a quintessential 60's look and feel. Ibanez designed the AMF with the aim of bringing the traditional tone and look of hollow body guitars into more modern musical realms.



AMF73 BK
BK (Black)

AMF73 TF
TF (Tobacco Flat)

AMF73

- Artcore Mahogany set-in neck
- Maple top/back/sides
- Medium frets • ART-1 bridge
- ACH1-S (H) neck pu
- CH2-S (H) bridge pu
- Hardware color : Chrome
- Scale : 628mm/24.75"
- Depth: 43mm at tail
- Colors : BK (Black)
TF (Tobacco Flat)



Sure Grip Knobs

Designed for precise control of knobs with non-slip functionality, while nice and classic look.



AMF/Body Thickness

The AMF body is flat-top and slender with semi-hollow construction, offering a bit more solid rock feel, yet warmer tone than a solid electric guitar.



U-Nam

AS The AS is a semi-acoustic guitar built to tackle just about any genre of music you throw at it. The pickups are mounted into a sustain block for increased sustain and feedback elimination. The Quik Change III bridge makes it easy to change strings without a lot of time involved.



Semi Hollow body construction



Ryan Helm
-Demon Hunter
Photo by Evan Duly



Eric Krasno
-Soulive

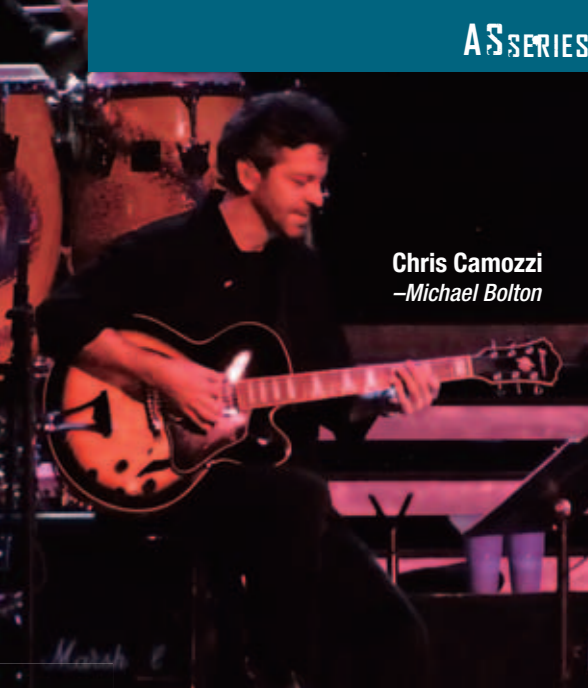

Chris Camozzi
-Michael Bolton



AS103 NT
NT (Natural)

AS103 VB
VB (Vintage Burst)

AS103

- 5pc Artcore Maple/Walnut set-in neck
- Flamed Maple top/back/sides
- Medium frets
- ART-1 bridge
- Quik Change III tailpiece
- Super 58 Custom (H) neck pu
- Super 58 Custom (H) bridge pu
- Hardware color : Gold
- Scale : 628mm/24.75"
- Depth: 43mm at tail
- Colors : NT (Natural) / VB (Vintage Burst)

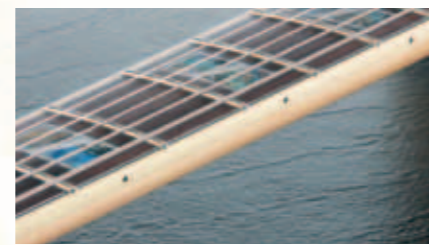

Custom Fret Edge Treatment

AS93 VLS

- 3pc Artcore Mahogany/Maple set-in neck
- Flamed Sycamore top/back/sides
- Medium frets
- ART-1 bridge
- Quik Change III tailpiece
- ACH1 (H) neck pu
- ACH2 (H) bridge pu
- Hardware color : Gold
- Scale : 628mm/24.75"
- Depth: 43mm at tail
- Color : VLS (Violin Sunburst)



AS73 BS
BS (Brown Sunburst)

AS73 IV
IV (Ivory)

AS73T TCR

- Artcore Mahogany set-in neck
- Maple top/back/sides
- Medium frets
- ART-2 Roller bridge • VBS80 vibrato
- ACH1 (H) neck pu • ACH2 (H) bridge pu
- Hardware color : Chrome
- Scale : 628mm/24.75"
- Depth: 43mm at tail
- Color : TCR (Transparent Cherry)

AS73

- Artcore Mahogany set-in neck
- Maple top/back/sides
- Medium frets • ART-1 bridge
- Quik Change III tailpiece
- ACH1 (H) neck pu • ACH2 (H) bridge pu
- Hardware color : Chrome
- Scale : 628mm/24.75"
- Depth: 43mm at tail
- Colors : BS (Brown Sunburst)
IV (Ivory)



VBS80 Vintage
Ibanez VBS80 Vintage Vibrato for semi acoustic guitars

AS73B BKF

- Artcore Mahogany set-in neck
- Maple top/back/sides
- Medium frets • ART-1 bridge
- Quik Change III tailpiece
- ACH1-S (H) neck pu
- ACH2-S (H) bridge pu
- Hardware color : Chrome
- Scale : 628mm/24.75"
- Depth: 43mm at tail
- Color : BKF (Black Flat)

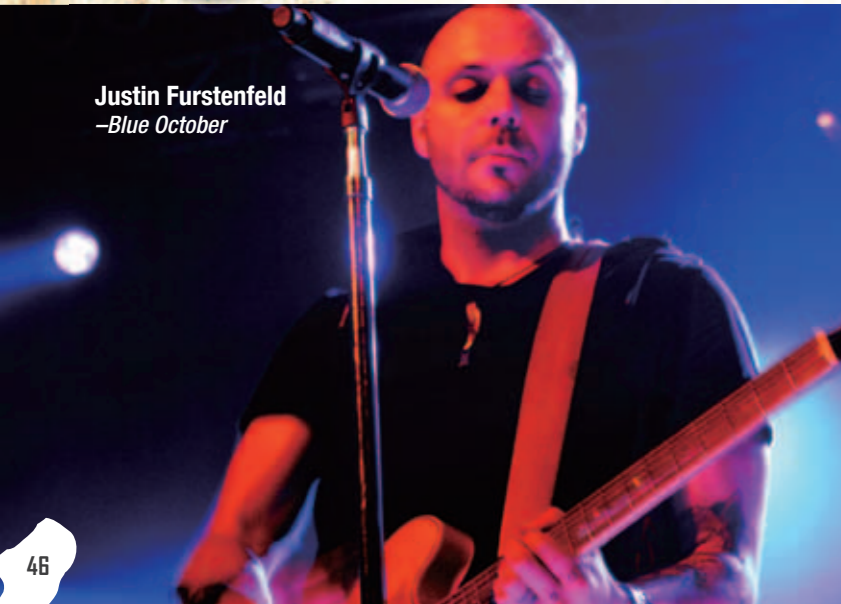

Justin Furstenfeld
-Blue October

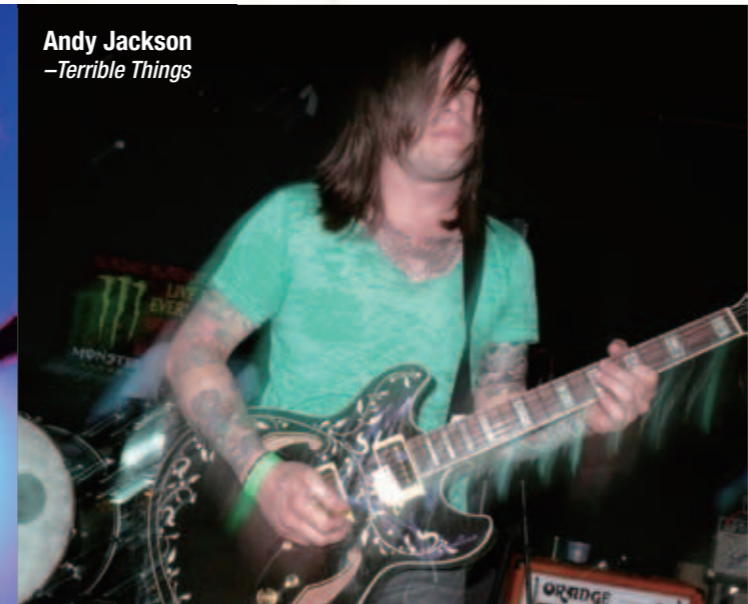

Andy Jackson
-Terrible Things

AF The AF is the most traditional of the Artcore series. The traditional full-hollow construction means there are no sound blocks in the body. Producing rich and complex tones, the AF is the guitar for the purist in all of us.



Artcore Custom Neck

Artcore Custom models feature 5pc maple/walnut neck for extra strength and stability.

VBF70 Vintage Vibrato

This old school vibrato adds country and rockabilly nuances to the rich tone of a full-hollow guitar, but the included roller saddles eliminate "old school" tuning problems.

*VBF70 Vintage Vibrato design licensed by Fred W. Gretsch Enterprises, Ltd. in the U.S.



AF125 AMB

- 5pc Artcore Maple/Walnut set-in neck
- Quilted Maple top/back/sides
- Medium frets • ART-1 bridge
- VT04 Custom tailpiece
- Super 58 Custom (H) neck pu
- Super 58 Custom (H) bridge pu
- Hardware color : Gold
- Scale : 628mm/24.75"
- Depth: 70mm at tail
- Color : AMB (Amber Burst)

AF105 VB

- 5pc Artcore Maple/Walnut set-in neck
- Flamed Maple top/back/sides
- Medium frets • ART-1 bridge
- VT04 Custom tailpiece
- Super 58 Custom (H) neck pu
- Super 58 Custom (H) bridge pu
- Hardware color : Gold
- Scale : 628mm/24.75"
- Depth: 70mm at tail
- Color : VB (Vintage Burst)

AF95 VLS

- 3pc Artcore Mahogany/Maple set-in neck
- Flamed Sycamore top/back/sides
- Medium frets • ART-1 bridge
- VT100DX tailpiece
- ACH1 (H) neck pu
- ACH2 (H) bridge pu
- Hardware color : Gold
- Scale : 628mm/24.75"
- Depth: 70mm at tail
- Color : VLS (Violin Sunburst)

AF75TDG IV

- Artcore Mahogany set-in neck
- Maple top/back/sides
- Medium frets • ART-2 Roller bridge
- VBF70 vibrato
- ACH1 (H) neck pu
- ACH2 (H) bridge pu
- Hardware color : Gold
- Scale : 628mm/24.75"
- Depth: 70mm at tail
- Color : IV (Ivory)

AF75 BS

- Artcore Mahogany set-in neck
- Maple top/back/sides
- Medium frets • ART-1 bridge
- VT60 tailpiece
- ACH1 (H) neck pu
- ACH2 (H) bridge pu
- Hardware color : Chrome
- Scale : 628mm/24.75"
- Depth: 70mm at tail
- Color : BS (Brown Sunburst)

AFS

Pushing traditional concepts one step further, the Ibanez AFS has the same shape and full-hollow body of the AF. For increased comfort and more midrange punch, the body depth is one inch thinner. An Ibanez Vintage Vibrato is also mounted on the body with roller saddles, eliminating the tuning problems of traditional systems.

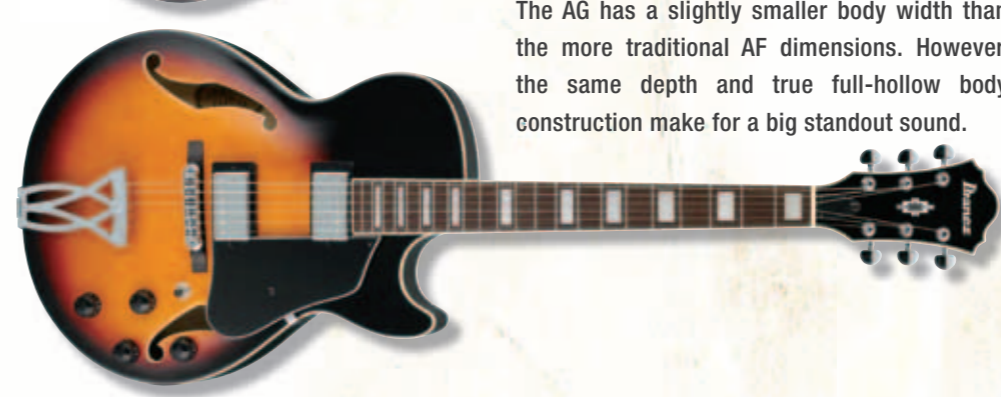

AK

Jazz and blues history is filled with the warm tones of large hollow body guitars. The AK escapes from the bright sound of maple tops and metal bridges, replacing them with a spruce top and an all-wood bridge.

AFS75T TRD

- Artcore Mahogany set-in neck
- Maple top/back/sides
- Medium frets • ART-2 Roller bridge
- VBF70 vibrato
- ACH1 (H) neck pu
- ACH2 (H) bridge pu
- Hardware color : Chrome
- Scale : 628mm/24.75"
- Depth: 43mm at tail
- Color : TRD (Transparent Red)

AK95 DVS

- 3pc Artcore Mahogany/Maple set-in neck
- Spruce top/Sycamore back/sides
- Medium frets • ART-W wooden bridge
- VT100DX tailpiece
- ACH1 (H) neck pu
- ACH2 (H) bridge pu
- Hardware color : Gold
- Scale : 628mm/24.75"
- Depth: 70mm at tail
- Color : DVS (Dark Violin Sunburst)

AK80 BS

- 3pc Artcore Mahogany/Maple set-in neck
- Spruce top/Sycamore back/sides
- Medium frets • ART-W wooden bridge
- VT60 tailpiece
- ACH1 (H) neck pu
- ACH2 (H) bridge pu
- Hardware color : Chrome
- Scale : 628mm/24.75"
- Depth: 70mm at tail
- Color : BS (Brown Sunburst)

AG75 BS

- Artcore Mahogany set-in neck
- Maple top/back/sides
- Medium frets • ART-1 bridge
- VT60 tailpiece
- ACH1 (H) neck pu
- ACH2 (H) bridge pu
- Hardware color : Chrome
- Scale : 628mm/24.75"
- Depth: 70mm at tail
- Color : BS (Brown Sunburst)

AG

The AG has a slightly smaller body width than the more traditional AF dimensions. However, the same depth and true full-hollow body construction make for a big standout sound.



AFS/Body Comparison

The AFS body features full-hollow construction, offering traditional jazz tone and midrange punch, yet it's thinner than traditional jazz boxes for easier playability.



ART-W Wooden Bridge

GEORGE BENSON SIGNATURE MODELS

George Benson's taste, tone, bluesy phrasing, and incomparable sense of swing has ensured his place in the history of jazz guitar. Ibanez is extremely proud of our long and fruitful relationship, now celebrating over 30 years of collaboration. The GB models are some of the finest jazz guitars on the market today.



GB Special Pickups
Floating pickups on the GB10 eliminate feedback.



Half-Bone/Half Brass Nut
The splendid George Benson Signature GB10 features a specially-designed half bone/half brass nut.



GB10 BS
BS (Brown Sunburst)

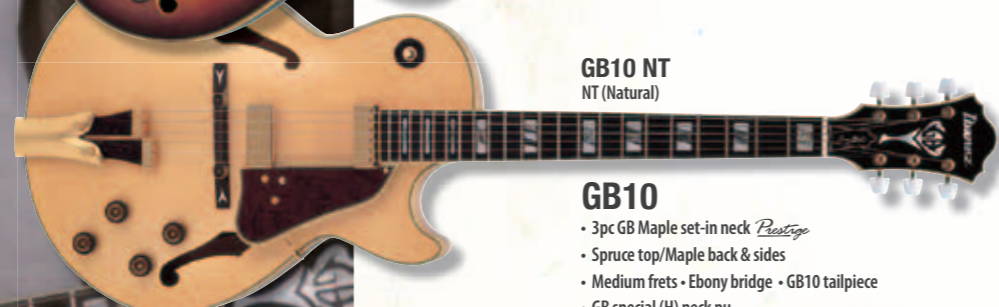

GB10 NT
NT (Natural)



GB200 BST

- 3pc GB Mahogany/Maple set-in neck *Prestige*
- Spruce top/Maple back & sides
- Medium frets - Ebony bridge - GB200 tailpiece
- Super 58 (H) neck pu
- Super 58 (H) bridge pu
- Hardware color : Gold
- Scale : 628mm/24.75"
- Depth : 80mm at tail
- Color : BST (Brown Sunburst)



PAT METHENY SIGNATURE MODELS

An Ibanez Signature artist since 1996, Pat's adventurous forays into jazz, pop, folk, and Latin music have enthralled audiences all over the world. At the core of these journeys are, of course, Pat's sumptuous guitar playing and his Ibanez Signature instruments.

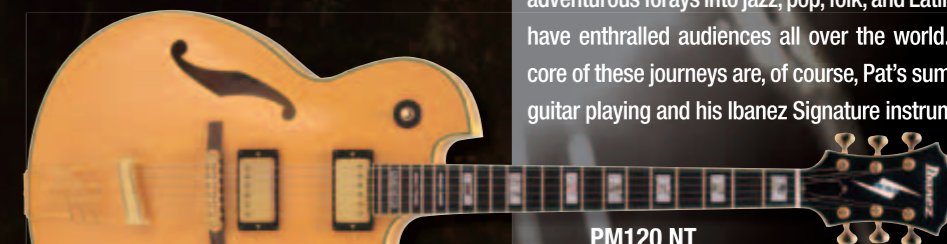

PM120 NT
NT (Natural)



PM120 BK
BK (Black)



PM120

- PM Mahogany set-in neck *Prestige*
- Maple top/back/sides
- Medium frets - Gotoh® 103B bridge - PM tailpiece
- Silent 58 (H) neck pu - Silent 58 (H) bridge pu
- Hardware color : Gold
- Scale : 628mm/24.75"
- Depth : 50mm at tail
- Colors : BK (Black) / NT (Natural)



PM35 NT

- 5pc PM Maple/Walnut set-in neck
- Maple top/back/sides - Medium frets
- ART-1 bridge - KT30 tailpiece
- Super 58 Custom (H) neck pu
- Hardware color : Gold
- Scale : 628mm/24.75"
- Depth : 70mm at tail
- Color : NT (Natural)

JOHN SCOFIELD SIGNATURE MODEL

Guitarist John Scofield has blazed a fearless trail, moving effortlessly in and out of bop, fusion, rock, funk, blues, and soul. Since becoming an Ibanez Signature artist in 2001, John's trusted JSM100 has been at the ready, waiting for the next adventurous musical turn in the road.



Photo by Nick Suttle



JSM100 VT

- JSM Mahogany set-in neck *Prestige*
- Flamed Maple top / back / sides
- Jumbo frets
- Gotoh® 510BN bridge
- Gotoh® GE101A tailpiece
- Super 58 (H) neck pu - Super 58 (H) bridge pu
- Hardware color : Gold
- Scale : 628mm/24.75" - Depth : 43mm at tail
- Color : VT (Vintage Sunburst)



Simon Andersson Avatar	Yann Armellino	Paul Baayens Hail of Bullets	Ralph Bach J.B.O.	Terry Balsamo Evanescence	Honza Kirk Behunek Solo Artist, SEVEN	Jackson Bengé (HED) p. e.
Alberto Bollati "El Guapo" UTEZ, Wine Spirit	Dennis Bradley Beneath the Massacre	Thomas "Buschy" Buschhausen Callejon	Rudi Buttas PUR	Martin Buus Mercenary	Buzzard 36 Crazyfists	Noah Carpenter Skinless
Giacomo Castellano Gianna Nannini	Cesareo Elio e le Storie Tese	Andy Chandler In Dread Response, The Mark of Man	Choky Netral	Tony Choy Area 305, Synchronicity	Alex Colin-Tocqaine Agressor, Loudblast	Joe Crawford PUR
Jim Davies Hyper, Victory Pill	Mark Davis Emmure	Niko Del Hierro Saratoga	Simone Dow VOYAGER	Fletcher Dragge Pennywise	Kenneth Lain Duncan We Butter the Bread with Butter	Nidas Engelin Engel
Lorenzo Feliciati Niccolò Fabi	Max Flövik Lillasyster	John Gahlert Deadlock	Gravy Mushroomhead	Karl Groom Threshold, Shadowland	Trent Hafdahl After The Burial	Filip Hantusch War from a Harlots Mouth
Simon Hawemann War from a Harlots Mouth	Kasper Heikkinen Amberian Dawn, Guardians of Mankind	Henna Stalingrad Cowgirls	Franck Hermann Adagio	Tony Hernando Saratoga	Pontus Hjelm Dead by April	Wojciech Hoffmann Turbo
Jan Hoffmann Long Distance Calling	Steve Holt 36 Crazyfists	Trond "Teeny" Holter Wig Wam	Bernhard Horn Callejon	Anders Iwers Tiamat	Bernt "Flash" Jansen Wig Wam	Sven Janssens The End of All Reason
Jonas Jarlsby Avatar	Neil Jones Session	Jari Kainulainen Symfonia	Kessier SERAPHIM	Gav King Fields of the Nephilim	Siméon Koch Eluveitie	Jukka Koskinen Wintersun, Norther, Amberian Dawn
Steinar Krokmo Pagan's Mind	Lanvall Edenbridge	Igor Lapuhin Nogu Svelo	Fredrik Larsson HammerFall	Parker Lauzon Evans Blue	Eugeny Levin Alisa	Holger Lieberenz Letzte Instanz
Jani Liimatainen Cain's Offering	Manu Livertout Manu Livertout band	Juan Pablo Lobos	Juan Carlos Martin Lopez Mago de Oz	Justin Lowe After The Burial	Jari Mäenpää Wintersun	Christofer Malmström Darkane

ELECTRIC BASSES



SR Prestige

The SR Prestige is the pinnacle of playing comfort, smart design, and Japanese craftsmanship. All SR Prestige models are "Made in Japan" by the finest Ibanez craftsmen and from top-of-the-line components. They feature the Mono-Rail bridge design, with complete string-to-string isolation so that each string vibrates without interference from other strings, the newly developed Power Curve III EQ for vitalizing the low-end and midrange tones, and the same classic slim neck that has become an industry standard over the past 20 years.

USA Bartolini® pickup

The US made pickups are hand made at our factory in California exclusively for Ibanez. Ibanez was the first to ask for much deeper tone from the neck pickup while retaining a bright tone for the bridge, unlike traditional designs that used approximately equal pickup tone. The pickups are dual coil designs in several soapbar shapes, some rounded top and some flat top. In all cases, the Neck pickup tone is very deep and the Bridge pickup tone is bright. This allows the widest tonal sweep from the Blend control. Enjoy the wide tonal range! -Bill Bartolini-

MR4 Mono-Rail Bridge

The Mono-Rail Bridge is the ultimate in string isolation for bass. Each saddle is independently and securely locked down to the body for maximum vibration transfer and no interference. One screw controls the height of each saddle for easy adjustment.

Dustin Davidson
-August Burns Red

Jeanne Sagan
-All That Remains

Marco Coti Zelati
-Lacuna Coil



SR5000E OL

- 5pc Atlas-4 HP Wenge/Bubinga neck *Prestige*
- w/KTS™ TITANIUM Reinforcement
- BLACK TUSQ XL® NUT
- Wenge/Mahogany/Wenge body • Medium frets
- MR-4 bridge (19mm string spacing)
- USA Bartolini® Custom neck pu
- USA Bartolini® Custom bridge pu
- PWC III 3-band eq • Elixir® strings
- Hardware color : Gold
- Scale : 864mm/34"
- Color : OL(Oil)



SR5005E OL

- 5pc Atlas-5 HP Wenge/Bubinga neck *Prestige*
- w/KTS™ TITANIUM Reinforcement
- BLACK TUSQ XL® NUT
- Wenge/Mahogany/Wenge body • Medium frets
- MR-4 bridge (16.5mm string spacing)
- USA Bartolini® Custom neck pu
- USA Bartolini® Custom bridge pu
- PWC III 3-band eq • Elixir® strings
- Hardware color : Gold
- Scale : 864mm/34"
- Color : OL(Oil)



SR5006E OL

- 5pc Atlas-6 HP Wenge/Bubinga neck *Prestige*
- w/KTS™ TITANIUM Reinforcement
- BLACK TUSQ XL® NUT
- Wenge/Mahogany/Wenge body • Medium frets
- MR-4 bridge (16.5mm string spacing)
- USA Bartolini® Custom neck pu
- USA Bartolini® Custom bridge pu
- PWC III 3-band eq • Elixir® strings
- Hardware color : Gold
- Scale : 864mm/34"
- Color : OL(Oil)

Maple Fingerboard, Maple/Bubinga 5pc Neck

The fingerboard and neck provide a sharp, clear and tight sound.



SR4500E NT
NT(Natural)



SR4500E DE
DE(Deep Espresso)

SR4500E

- 5pc Atlas-4 HP Maple/Bubinga neck *Prestige*
- w/KTS™ TITANIUM Reinforcement
- BLACK TUSQ XL® NUT
- Ash body • Medium frets
- MR-4 bridge (19.0mm string spacing)
- USA Bartolini® Custom neck pu
- USA Bartolini® Custom bridge pu
- PWC III 3-band eq • Elixir® strings
- Hardware color : Cosmo Black
- Scale : 864mm/34"
- Colors : NT(Natural)
DE(Deep Espresso)

Power Curve III

The Power Curve III 3-band EQ was developed specifically for our SR Prestige line. The Mid Q control makes adjustment of the core of your bass - the mids - extremely simple, and the +/-12dB EQ variable range enables a more natural sounding bass tone. Equipped with an EQ On/Off switch that outputs directly from the Bartolini® pickup.

Ash Body

The ash body is characterized by strong mid- and high-range tones and excellent sustain. Attack and response are also excellent.



Body Lamination

Ovankol top lamination gives the bass a premium feel along with a strong presence.

SR PREMIUM

The Ibanez SR bass is well known for its playing comfort and flexibility like no others. The SR Premium has the classic slim neck and comes equipped with the high profile MR4 Mono-Rail bridge. In addition to those the traditional features of SR, its select wood materials, and the combination of Nordstrand™ pickups and EQB-III SC—specially customized EQ for the SR Premium—deliver you uncompromised playability.

Nordstrand™ Pickups

Nordstrand™ pickups provide the clear sound characteristic of single coil pickups, while the large body gives players a powerful and aggressive tone.

Premium Fret Edge Treatment

The premium fret edges are processed to be specially rounded for smooth play and comfortable neck grip.

EQB-III SC

The EQB-III SC is a newly customized 3-Band EQ and a dedicated preamp for Nordstrand™ pickups for further pure and wider frequency response. This preamp system is equipped with an EQ bypass switch and a mid-frequency select switch (250Hz or 600Hz).

**SR1200 VNF**

- 5pc Atlas-4 Wenge/Bubinga neck w/KTS™ TITANIUM Reinforcement
- BLACK TUSQ XL® NUT
- Ovankol top / Mahogany body • Medium frets
- MR-4 bridge (19.0mm string spacing)
- Nordstrand™ BigSingle 4 neck pu
- Nordstrand™ BigSingle 4 bridge pu
- EQB-III SC 3-band eq • Elixir® strings
- Hardware color : Gold
- Scale : 864mm/34"
- Colors : VNF (Vintage Natural Flat)

SR1205 VNF

- 5pc Atlas-5 Wenge/Bubinga neck w/KTS™ TITANIUM Reinforcement
- BLACK TUSQ XL® NUT
- Ovankol top / Mahogany body • Medium frets
- MR-4 bridge (16.5mm string spacing)
- Nordstrand™ BigSingle 5 neck pu
- Nordstrand™ BigSingle 5 bridge pu
- EQB-III SC 3-band eq • Elixir® strings
- Hardware color : Gold
- Scale : 864mm/34"
- Colors : VNF (Vintage Natural Flat)

SR STANDARD

Since 1987, musicians all over the world have come to know the playing comfort and unique sound of the SR bass. This year's lineup includes a wide array of options sure to fit just about any style of music. With 3-band EQ and its Mid-Frequency Select switch, or the Style Sweeper 3-band EQ controls, the SR basses can produce any sound you require.

Jeroen Paul Thesseling
—Pestilence
Photo by Nuno Alexandre / eosphoto.eu



Ryan Wombacher
—Bleeding Through

SR700

- 5pc SR4 Jatoba/Bubinga neck
- Figured Maple/Mahogany wing body w/Maple center block
- Medium frets
- Accu-Cast B20 bridge (19mm string spacing)
- Bartolini® MK1 neck pu
- Bartolini® MK1 bridge pu
- EQB-III S 3-band eq
- Elixir® strings
- Hardware color : Cosmo Black
- Scale : 864mm/34"
- Colors : AM (Amber)
CN (Charcoal Brown)

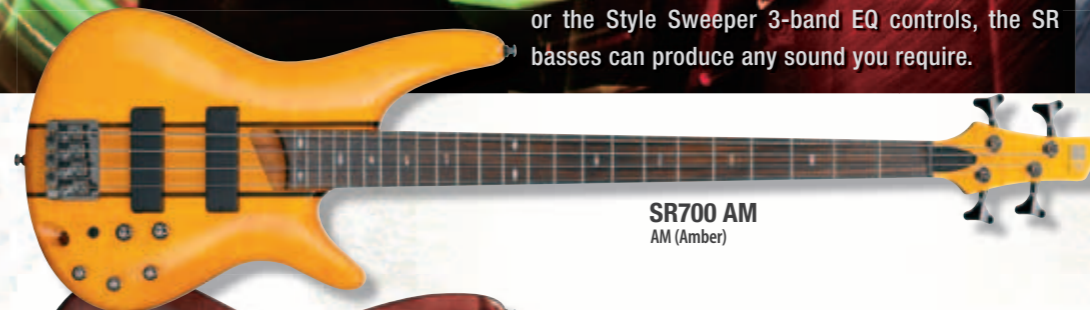

SR700 AM
AM (Amber)



SR700 CN
CN (Charcoal Brown)

SR705 TK

- 5pc SR5 Jatoba/Bubinga neck
- Figured Maple/Mahogany wing body w/Maple center block
- Medium frets
- Accu-Cast B25 bridge (16.5mm string spacing)
- Bartolini® MK1 neck pu • Bartolini® MK1 bridge pu
- EQB-III S 3-band eq • Elixir® strings
- Hardware color : Cosmo Black
- Scale : 864mm/34"
- Color : TK (Transparent Black)

**EQB-III S**

In addition to 3-band EQ, the SR is now equipped with a mid-frequency select switch, enabling you to instantly select 250Hz and 600Hz—the heart of the mid zone—for a more dynamic and ideal tone.

**Extended Neck Joint**

The neck tongue not only creates a unique look, it also makes the joint stronger.



Karin Axelsson
–Sonic Syndicate

SR



Matt Snell
–Five Finger Death Punch



Sami Hinkka
–Ensiferum

Photo by Audrey Duardin / Shutterstock.net



Sandra Völkl
–Equilibrium



Andrew Jacobs
–Mutiny Within

Stephane Barbe
–Kataklysm



SR600 NTF

- 5pc SR4 Jatoba/Bubinga neck
- Ash body • Medium frets
- Accu-Cast B20 bridge (19mm string spacing)
- Bartolini® MK1 neck pu
- Bartolini® MK1 bridge pu
- EQB-IIIS 3-band eq
- Elixir® strings
- Hardware color : Black Matte
- Scale : 864mm/34"
- Color : NTF (Natural Flat)



SR500 BM

- 5pc SR4 Jatoba/Bubinga neck
- Mahogany body • Medium frets
- Accu-Cast B20 bridge (19mm string spacing)
- Bartolini® MK1 neck pu
- Bartolini® MK1 bridge pu
- EQB-IIIS 3-band eq
- Elixir® strings
- Hardware color : Cosmo Black
- Scale : 864mm/34"
- Color : BM(Brown Mahogany)



SR500M BM

- 5pc SR4 Maple/Rosewood neck
- Mahogany body • Medium frets
- Accu-Cast B20 bridge (19mm string spacing)
- Bartolini® MK1 neck pu
- Bartolini® MK1 bridge pu
- EQB-IIIS 3-band eq
- Elixir® strings
- Hardware color : Cosmo Black
- Scale : 864mm/34"
- Color : BM (Brown Mahogany)



Jatoba/Bubinga Slim Neck

Coupling Jatoba with Bubinga has made the neck strong and stable despite its thinness.



MK1 Pickups

The MK1 pickups are split coil designs that provides a very wide frequency range and enhanced definition for maximum accuracy. The Neck and Bridge pickups have equal response, like traditional single coils, but without the hum and noise.



SR605 NTF

- 5pc SR5 Jatoba/Bubinga neck
- Ash body • Medium frets
- Accu-Cast B25 bridge (16.5mm string spacing)
- Bartolini® MK1 neck pu
- Bartolini® MK1 bridge pu
- EQB-IIIS 3-band eq
- Elixir® strings
- Hardware color : Black Matte
- Scale : 864mm/34"
- Color : NTF (Natural Flat)



SR505 BM

- 5pc SR5 Jatoba/Bubinga neck
- Mahogany body • Medium frets
- Accu-Cast B25 bridge (16.5mm string spacing)
- Bartolini® MK1 neck pu
- Bartolini® MK1 bridge pu
- EQB-IIIS 3-band eq
- Elixir® strings
- Hardware color : Cosmo Black
- Scale : 864mm/34"
- Color : BM(Brown Mahogany)



SR505M BM

- 5pc SR5 Maple/Rosewood neck
- Mahogany body • Medium frets
- Accu-Cast B25 bridge (16.5mm string spacing)
- Bartolini® MK1 neck pu
- Bartolini® MK1 bridge pu
- EQB-IIIS 3-band eq
- Elixir® strings
- Hardware color : Cosmo Black
- Scale : 864mm/34"
- Color : BM (Brown Mahogany)



SR506 BM

- 5pc SR6 Jatoba/Bubinga neck
- Mahogany body • Medium frets
- B106 bridge (16.5mm string spacing)
- Bartolini® MK1 neck pu
- Bartolini® MK1 bridge pu
- EQB-IIIS 3-band eq
- Elixir® strings
- Hardware color : Cosmo Black
- Scale : 864mm/34"
- Color : BM(Brown Mahogany)

SR STANDARD



SR300 IPT
IPT (Iron Pewter)



SR300 PW
PW (Pearl White)



SR300 SLB
SLB (Starlight Blue)



SR300 ROM
ROM (Roadster Orange Metallic)



SR300 CA
CA (Candy Apple)



SR300

- 5pc SR4 Maple/Rosewood neck
- Agathis body
- Medium frets
- B100 bridge (19mm string spacing)
- EXF-4F neck pu
- EXF-4R bridge pu
- EQB-IIIB Style Sweeper 3-band eq
- Hardware color : Cosmo Black
- Scale : 864mm/34"
- Colors : IPT (Iron Pewter)
PW (Pearl White)
SLB (Starlight Blue)
ROM (Roadster Orange Metallic)
CA (Candy Apple)
- Also available left-handed model in IPT finish (SR300L IPT)



Style Sweeper

With the Style Sweeper 3 Band EQ controls, you can boost mids for a plucky finger sound or scoop them for a resonant slap sound with the turn of a knob.

SR305 IPT

- 5pc SR5 Maple/Rosewood neck
- Agathis body
- Medium frets
- B105 bridge (16.5mm string spacing)
- EXF-5F neck pu
- EXF-5R bridge pu
- EQB-IIIB Style Sweeper 3-band eq
- Hardware color : Cosmo Black
- Scale : 864mm/34"
- Color : IPT (Iron Pewter)

Paul Romanko
-*Shadows Fall*



SRX

The SRX is the muscular big brother of the SR series. This is a bass that was designed for heavier playing styles, and it meets that demand in a no-nonsense layout. The EQB-II DX 2-band EQ makes it easy to find various sounds, and the now-famous stock Ibanez PFR pickups, which major artists rave about, are right there to give you that extra punch.



SRX430

- 3pc SRX4 Maple neck
- Mahogany body
- Medium frets
- Accu-Cast B200 bridge (19mm string spacing)
- PFR-N4 neck pu
- PFR-B4 bridge pu
- EQB-II DX 2-band eq
- Hardware color : Black
- Scale : 864mm/34"
- Colors : RD (Red)
WH (White)

SRX430 RD
RD (Red)



SRX430 WH
WH (White)



SRX360 BK

- 3pc SRX4 Maple neck
- Mahogany body
- Medium frets
- Accu-Cast B200 bridge (19mm string spacing)
- PFR-N4 neck pu
- PFR-B4 bridge pu
- EQB-II DX 2-band eq
- Hardware color : Chrome
- Scale : 864mm/34"
- Color : BK (Black)



Accu-Cast B200

The B200 bridge provides SRX basses with massive, low-mid sound.

PFR Pickups & EQB-II DX

These powerful full-range passive pickups generate high output with extra low midrange punch. The EQB-II DX 2-band EQ enhances heavy tones with simple operation.



Nelson Braxton
-*Braxton Bros, Michael Bolton*



Carol Kaye

GSR

There are wide variations among our GSR series guitars. The GSR200 combines straight ahead sounds with the high playability of an SR. The GSR200EX gives a punchier sound, and the newly added GSRM20 is the perfect bass for kids who are just to starting to playing. Our Jumpstart Bass Package (see also P. 77) features a GSR and all the accessories you need to get up and jamming right from your first day.



GSR200 BK
BK (Black)



GSR200 JB
JB (Jewel Blue)



GSR200 TR
TR (Transparent Red)



GSR200 PW
PW (Pearl White)



GSR205 BK

- GSR5 Maple neck
- Agathis body
- Medium frets
- B15 bridge (16.5mm string spacing)
- DXH-5N neck pu
- DXH-5B bridge pu
- Hardware color : Chrome
- Scale : 864mm/34"
- Color : BK (Black)

GSR200

- GSR4 Maple neck
- Agathis body
- Medium frets
- B10 bridge (19mm string spacing)
- PSNDP neck pu
- PSNDJ bridge pu
- Phat II eq
- Hardware color : Chrome
- Scale : 864mm/34"
- Colors : BK (Black) JB (Jewel Blue) TR (Transparent Red) PW (Pearl White)
- Also available left-handed model in BK finish (GSR200L BK)



GSR200EX BKF
BKF (Black Flat)



GSR200EX GSF
GSF (Green Shadow Flat)

GSR200EX

- GSR4 Maple neck
- Mahogany body
- Medium frets
- B10 bridge (19mm string spacing)
- PPD4 neck pu
- PPD4 bridge pu
- Phat II eq
- Hardware color : Black
- Scale : 864mm/34"
- Colors : BKF (Black Flat) GSF (Green Shadow Flat)



GSR180 BK
BK (Black)



GSR180 BS
BS (Brown Sunburst)

GSR180

- GSR4 Maple neck
- Agathis body • Medium frets
- B10 bridge (19mm string spacing)
- PSNDJ neck pu
- PSNDJ bridge pu
- Hardware color : Chrome
- Scale : 864mm/34"
- Colors : BK (Black) BS (Brown Sunburst)



GSRM20 BK
BK (Black)



GSRM20 CA
CA (Candy Apple)

GSRM20

- GSRM Maple neck
- Mahogany body
- Medium frets
- B10 bridge (19mm string spacing)
- STD-P neck pu
- STD-J bridge pu
- Hardware color : Chrome
- Scale : 726.2mm/28.6"
- Colors : BK (Black) CA (Candy Apple)



MiKro Bag

ATK *Prestige*

The ATK may be the most straightforward bass in the entire Ibanez line. With its iconic double humbucker pickup, however, players can get three distinctive bass sounds to fit any genre or playing style instantly with a flick of a switch. The GATK20—the most basic version of the ATK—gives you a huge rock sound straightaway from the same big ATK body.

ATK1200 NT

- 3pc ATK4 HP Maple neck *Prestige*
- Ash body
- Medium frets
- ATK4 bridge (19mm string spacing)
- CAP-SAH4 neck pu
- CAP-DH bridge pu
- ATK N3 3-band eq
- D'Addario® Strings
- Hardware color: Chrome
- Scale: 864mm/34"
- Color: NT (Natural)



CAP Sonic Arch pu + CAP Double Humbucker pu

In addition to a CAP double humbucker pickup, a CAP Sonic Arch pickup is mounted on neck side. The input of these two pickups can be mixed using the newly developed balancer. Using the selectable 3 different pickup combinations of the CAP Double Humbucker pickup also allows for an even wider array of performance options.



ATK bridge

The ATK's original large bridge directly transmits string vibration to the body.



Marco Schaller
—Caliban



Mark Young
—(HED)p.e.



Tobias Schedler
—The Sorrow



ATK200 NT
NT (Natural)



ATK200 BK
BK (Black)

ATK200

- 3pc ATK4 Maple neck
- Ash body
- Medium frets
- ATK4 bridge (19mm string spacing)
- CAP-DH bridge pu
- ATK N2 3-band eq
- Elixir® strings
- Hardware color: Chrome
- Scale: 864mm/34"
- Colors: NT (Natural) BK (Black)

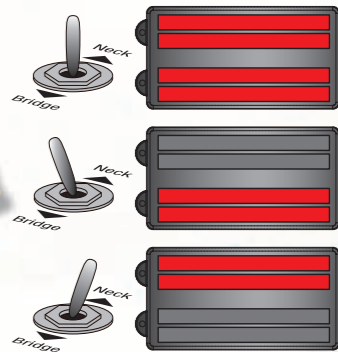

CAP Double Humbucker

ATK200 features the original Ibanez CAP Double Humbucker pickup, which offers three distinct sounds for all styles of playing. There are two humbucking coils inside one pickup, which can minimize noise by hum cancelling in each pickup position (neck, bridge and combined.) With each position, you will get a different tonal character of the ATK200.



John 'Slo' Maggard
—Unearth

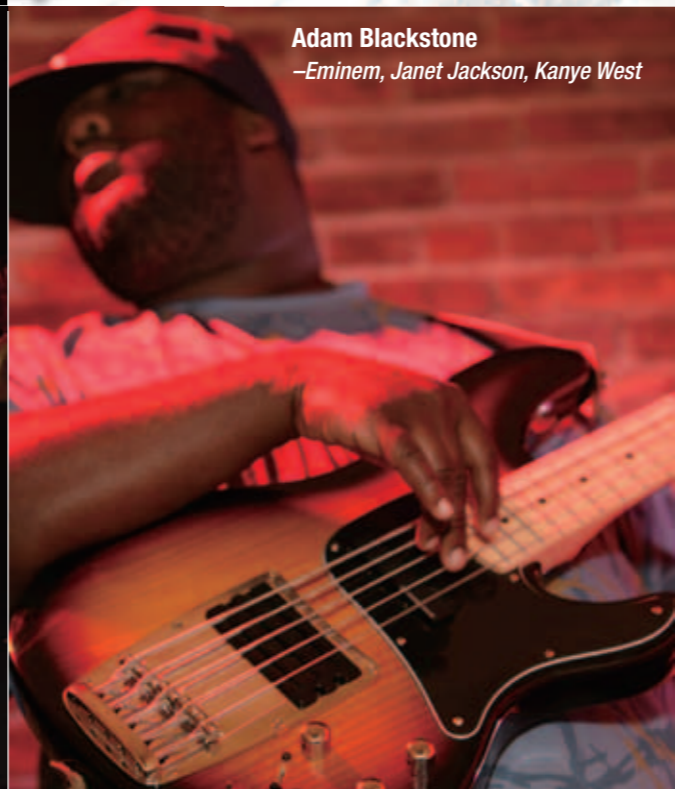

Adam Blackstone
—Eminem, Janet Jackson, Kanye West



GATK20 BK
BK (Black)



GATK20 CA
CA (Candy Apple)



Wilkinson Machine Heads

Wilkinson open gear tuners prevent drooping of the head caused by a heavy neck and give players comfort and stability in performance.

GATK20

- GATK4 Maple neck
- Mahogany body
- Medium frets
- B10 bridge (19mm string spacing)
- STD-M bridge pu
- Hardware color: Chrome
- Scale: 864mm/34"
- Colors: BK (Black)
CA (Candy Apple)

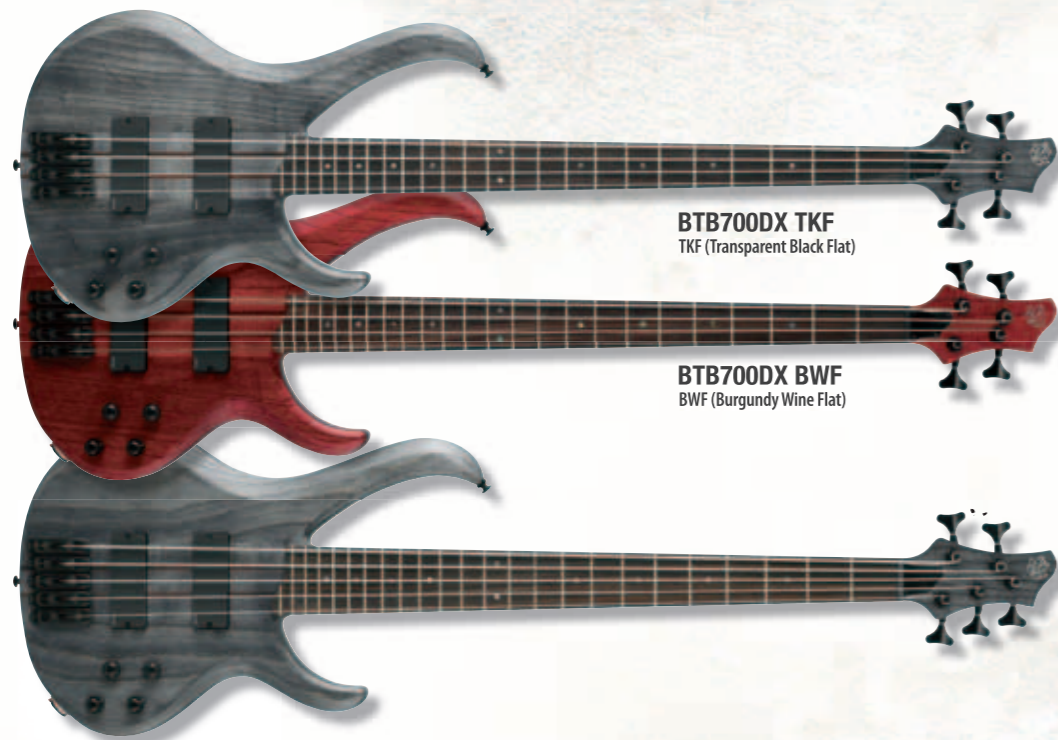

BTB700DX TKF
TKF (Transparent Black Flat)

BTB700DX BWF
BWF (Burgundy Wine Flat)

BTB700DX

- 5pc BTB4 Maple/Bubinga neck-thru
- Ash wing body • Medium frets
- MR-2 bridge (19mm string spacing)
- EMG® 40DC neck pu
- EMG® 40DC bridge pu
- Vari-Mid III 3-band eq
- Elixir® strings
- Hardware color : Black
- Scale : 889mm/35"
- Colors : TKF (Transparent Black Flat)
BWF (Burgundy Wine Flat)

BTB705DX TKF

- 5pc BTB5 Maple/Bubinga neck-thru
- Ash wing body • Medium frets
- MR-2 bridge (19mm string spacing)
- EMG® 40DC neck pu
- EMG® 40DC bridge pu
- Vari-Mid III 3-band eq
- Elixir® strings
- Hardware color : Black
- Scale : 889mm/35"
- Color : TKF (Transparent Black Flat)

BTB

The concepts behind boutique basses are often the justification for making them extremely expensive. With the BTB, however, Ibanez decided that these same concepts of well-selected body materials, a 35" neck scale, and deep cutaways could be applied to an instrument that anyone could afford. All BTB basses feature neck-thru construction and deeper cutaways for enhanced playability and balance.



EMG® Pickups

The EMG® 40DC pickups produce a deep low end while maintaining clarity with very low noise.



Bartolini® MK2 Pickups and EQ

The MK2 pickups are quad coil designs. The Neck pickup tone is very deep and the Bridge pickup tone is bright, just like the US made pickups. They are also balanced for output so that the deep tone Neck pickup does not overpower the Bridge pickup. The MK2 electronics compliments and enhances their wide tonal range.



Neck Thru construction

Neck-thru construction on the BTB series provides massive sustain and playing comfort.



BTB670 NTF

- 5pc BTB4 Maple/Bubinga neck-thru
- Walnut/Ash wing body • Medium frets
- MR-2 bridge (19mm string spacing)
- Bartolini® MK2 neck pu
- Bartolini® MK2 bridge pu
- Bartolini® MK2 3-band eq
- Elixir® strings
- Hardware color : Cosmo Black
- Scale : 889mm/35" • Color : NTF (Natural Flat)

BTB675 NTF

- 5pc BTB5 Maple/Bubinga neck-thru
- Walnut/Ash wing body • Medium frets
- MR-2 bridge (19mm string spacing)
- Bartolini® MK2 neck pu
- Bartolini® MK2 bridge pu
- Bartolini® MK2 3-band eq
- Elixir® strings
- Hardware color : Cosmo Black
- Scale : 889mm/35" • Color : NTF (Natural Flat)

BTB676 NTF

- 5pc BTB6 Maple/Bubinga neck-thru
- Walnut/Ash wing body • Medium frets
- MR-2 bridge (17mm string spacing)
- Bartolini® MK2 neck pu
- Bartolini® MK2 bridge pu
- Bartolini® MK2 3-band eq
- Elixir® strings
- Hardware color : Cosmo Black
- Scale : 889mm/35" • Color : NTF (Natural Flat)

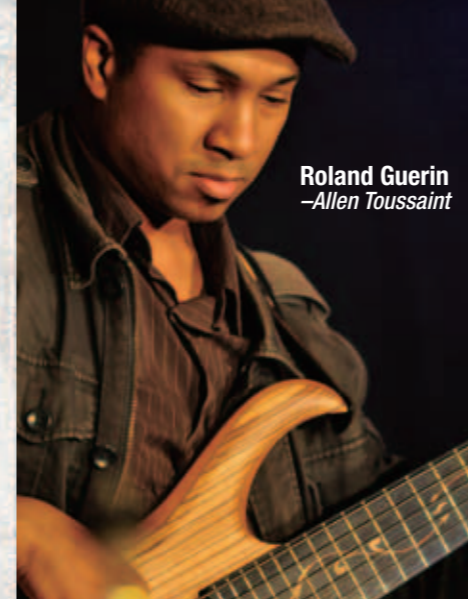

Roland Guerin
—Allen Toussaint



Lee Foral
—After the Burial



Stephen Bruner
—Suicidal Tendencies



Skinny Disco
—Deathstars

JTKB/ARTCORE

The JTKB300 is truly unique among Ibanez basses. Its mahogany body, high-powered pickups, and solid bridge can take a beating and still produce the warm, smooth sound of a vintage bass. The Artcore Bass series offers the acoustic tone of a hollow body and increased playing comfort with its 30" scale neck.



JTKB300 WH

- 3pc JTKB Maple neck
- Mahogany body • Medium frets
- JTB10 bridge (19mm string spacing)
- PSJ neck pu • PSJ mid pu • PSJ bridge pu
- Elixir® strings
- Hardware color : Chrome
- Scale : 864mm/34"
- Color : WH (White)



PSJ Pickup & PU Selector Switch

The JTKB is equipped with three single pickups, each with its own on/off switch. This creates a wealth of sound possibilities from an orthodox sound to a mesmerizing phase sound.



AFB200 BS

- 3pc Artcore Bass Mahogany/Maple set-in neck
- Maple top/back/sides • Medium frets
- Wooden bridge (19mm string spacing)
- FBT40 tailpiece
- ACHB-2 neck pu • ACHB-2 bridge pu
- D'Addario® Strings
- Hardware color : Gold
- Scale : 770mm/30.3"
- Depth : 70mm at tail
- String Gauge : .050/.070/.085/.105
- Color : BS (Brown Sunburst)



Sure Grip III Knob

Designed for precise control of knobs with non-slip functionality, while nice and classic look.



AGB200 TBR

- 3pc Artcore Bass Mahogany/Maple set-in neck
- Maple top/back/sides
- Medium frets
- Gibraltar III bass bridge (19mm string spacing)
- Quik Change III bass tailpiece
- ACHB-2 neck pu
- ACHB-2 bridge pu
- D'Addario® Strings
- Hardware color : Gold
- Scale : 770mm/30.3"
- Depth : 43mm at tail
- String Gauge : .050/.070/.085/.105
- Color : TBR (Transparent Brown)

Grooveline





Grooveline



Grooveline



G104

- 5pc Grooveline-4 Wenge/Bubinga neck
- w/KTS™ TITANIUM Reinforcement
- BLACK TUSQ XL® NUT
- Ash/Alder/Ash body
- Medium frets
- Tight End Bass 4 bridge (19.0mm string spacing)
- CAP SAH4 neck pu
- CAP SAH4 bridge pu
- E4 3-band eq
- Daddario® Strings
- Hardware color : Cosmo Black
- Scale : 864mm/34"
- Colors : NT(Natural)
DE(Deep Espresso)



G104 DE
DE (Deep Espresso)



G105

- 5pc Grooveline-5 Wenge/Bubinga neck
- w/KTS™ TITANIUM Reinforcement
- BLACK TUSQ XL® NUT
- Ash/Alder/Ash body
- Medium frets
- Tight End Bass 5 bridge (18.0mm string spacing)
- CAP SAH5 neck pu
- CAP SAH5 bridge pu
- E5 3-band eq
- Daddario® Strings
- Hardware color : Cosmo Black
- Scale : 864mm/34"
- Colors : TOR(Transparent Orange)
NT(Natural)
DE(Deep Espresso)



G104 NT
NT (Natural)



G105 TOR
TOR (Transparent Orange)

**Bartolini® GVB Pickups**

Bartolini® USA P45C pickups, featuring an extended and more resonant frequency range, are mounted on the GVB1006. They are Gerald's long-time choice for pickups.

GERALD VEASLEY SIGNATURE MODEL

Gerald is known in the bass community for his exceptional playing, and the GVB1006 signature bass builds on this legacy through legendary Japanese craftsmanship and an instrument rich in both features and visual beauty. Special specifications such as 14mm string spacing, Bartolini pickups, and a gorgeous figured maple top make the GVB a top choice for any bassist.

GVB1006 AM

- 3pc GVB Maple/Wenge neck *Prestige*
- Figured Maple top/Alder body
- Medium frets
- MR-4 bridge (14mm string spacing)
- Bartolini® P45C-B neck pu
- Bartolini® P45C-T bridge pu
- Aguilar® OBP-3
- Hardware color: Cosmo Black
- Scale: 864mm/34"
- Factory Tuning: 1C, 2G, 3D, 4A, 5E, 6B
- String Gauge: .030/.040/.060/.080/.100/.120
- Color: AM (Amber)

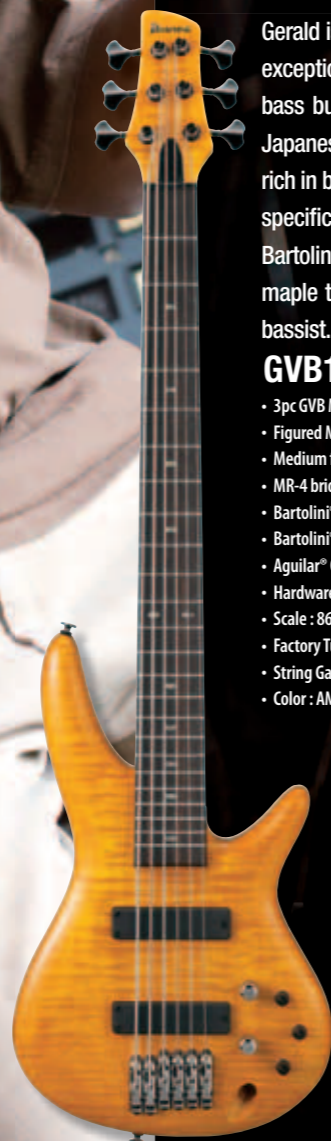
**AGUILAR® OBP-3 EQ**

GVB1006 features the Aguilar OBP-3 3-band eq, with ultra flexibility. It provides ± 18 dB of cut/boost at 40Hz, ± 16 dB of cut/boost at either 400Hz or 800Hz and ± 16 dB of treble cut/boost at 6.5 kHz. The mid frequency can be set to 400Hz or 800Hz by push/pull switch, both considered very important and useful frequencies for the bass.

**GWB35 BKF**

- 3pc GWB35 Maple neck
- Basswood body
- Fretless
- B105 bridge (16.5mm string spacing)
- SFR-GWB custom wound pu
- EQB-GWII 2-band eq
- D'Addario® strings
- Hardware color: Black
- Scale: 864mm/34"
- Color: BKF (Black Flat)

**GWB1005 NTF**

- 3pc GWB1005 Maple neck *Prestige*
- Swamp Ash body
- Fretless
- STD-5 bridge (16.5mm string spacing)
- Bartolini® GWB pu
- Bartolini® NTBT 2-band eq
- D'Addario® strings
- Hardware color: Black
- Scale: 864mm/34"
- Color: NTF (Natural Flat)

GARY WILLIS SIGNATURE MODELS

From Triphasic bassist Gary Willis, the acclaimed master of the five-string fretless, comes the design of the GWB, a no-frills, finely tuned instrument made for the player who desires total dynamic and tonal control.

Bartolini® GWB PU & NTBT EQ
Curved Bartolini® pickup provides separate coils for precise string balance (GWB1005NTF).



Korn FIELDY SIGNATURE MODEL

A lightweight bass but with some seriously heavy tone. With active pickups and the 3-band eq, any sound is possible. Korn's sound. Your sound.

K5 BKF

- 5pc K5 Maple/Bubinga neck
- Mahogany body
- Medium frets
- Die-Cast EB-7 bridge (16.5mm string spacing)
- ADXSN neck pu
- ADXSB bridge pu
- Vari-Mid III 3-band eq
- Elixir® strings
- Hardware color: Black
- Scale: 864mm/34"
- Color: BKF (Black Flat)

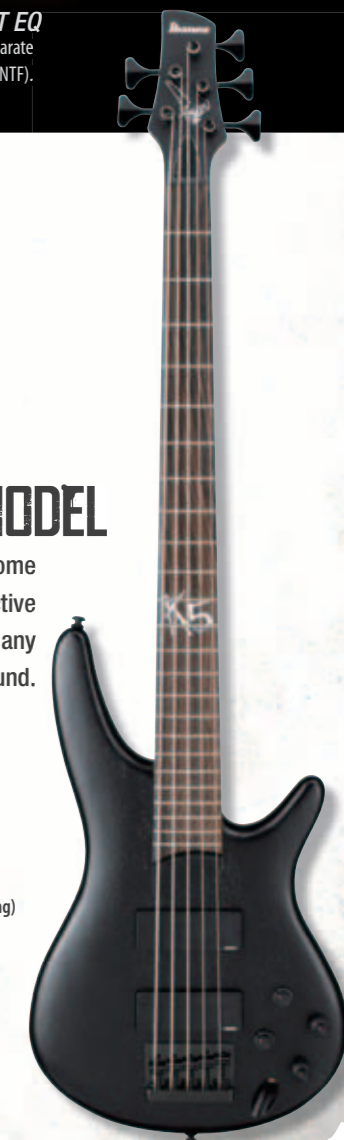

Photo by Sebastien Paquet



**KILLSWITCH
ENGAGE**

MIKE D'ANTONIO SIGNATURE MODEL

MDB2 BM

- 5pc MDB Maple/Walnut neck-thru
- Mahogany wing body • Medium frets
- Accu-Cast B200 bridge (19mm string spacing)
- PFR-ALN4 neck pu • PFR-ALB4 bridge pu
- 1-volume control w/MDB Active circuit
- D'Addario® strings
- Hardware color : Cosmo Black
- Scale : 864mm/34"
- Factory Tuning : 1F, 2C, 3G, 4C
- String Gauge : .055/ .075/ .095/ .120
- Color : BM (Brown Mahogany)

Sometimes straightforward brute force is the only answer. Killswitch Engage's Mike D'Antonio would agree. His signature MDB2, modeled after the SRX700, has a simplified layout of only one volume control and two PFR high-output pickups. Mike's striking laser-engraved graphic will ensure you get noticed while you're raging on this beast.

SDB1 BKF

- 5pc SDB Maple/Bubinga neck-thru
- Mahogany wing body • Medium frets
- MR-4 bridge (19mm string spacing)
- PFR-N4 neck pu (black pole piece)
- PFR-B4 bridge pu (black pole piece)
- EQB-II DX 2-band eq • D'Addario® strings
- Hardware color : Cosmo Black
- Scale : 864mm/34"
- Factory Tuning : 1D#, 2A#, 3F, 4C
- String Gauge : .060/ .080/ .100/ .120
- Color : BKF (Black Flat)

Any bass that takes the stage night after night with Arch Enemy has to take a brutal pounding without sacrificing tone. Made to Sharlee's custom specs with powerful PFR pickups and Iron Cross neck inlays, the Iceman-inspired SDB1 looks as sinister as it sounds.

ARCH ENEMY

SHARLEE D'ANGELO SIGNATURE MODEL



Photo by Oskar Allerby

PIB2 PW

- 5pc PIB Maple/Bubinga neck
- Maple body • Medium frets
- MR-4 bridge (16.5mm string spacing)
- USA Bartolini® Custom neck pu
- USA Bartolini® Custom bridge pu
- 1-volume control w/PIB Active circuit
- D'Addario® strings
- Hardware color : Gold • Scale : 864mm/34"
- Factory Tuning : 1D#, 2A#, 3F, 4C, 5A#
- String Gauge : .045/ .065/ .085/ .105/ .120
- Color : PW (Pearl White)

IN FLAMES

Iwers' bass playing in the band In Flames is as aggressive and ruthless as you can get, and this rock bass is built to take anything that comes its way. Just one look at its 5pc Maple/Bubinga neck, Maple body, and dramatic inlay over a Pearl White finish is all it takes to realize that this bass is a true battle axe.

PETER IWERS SIGNATURE MODEL

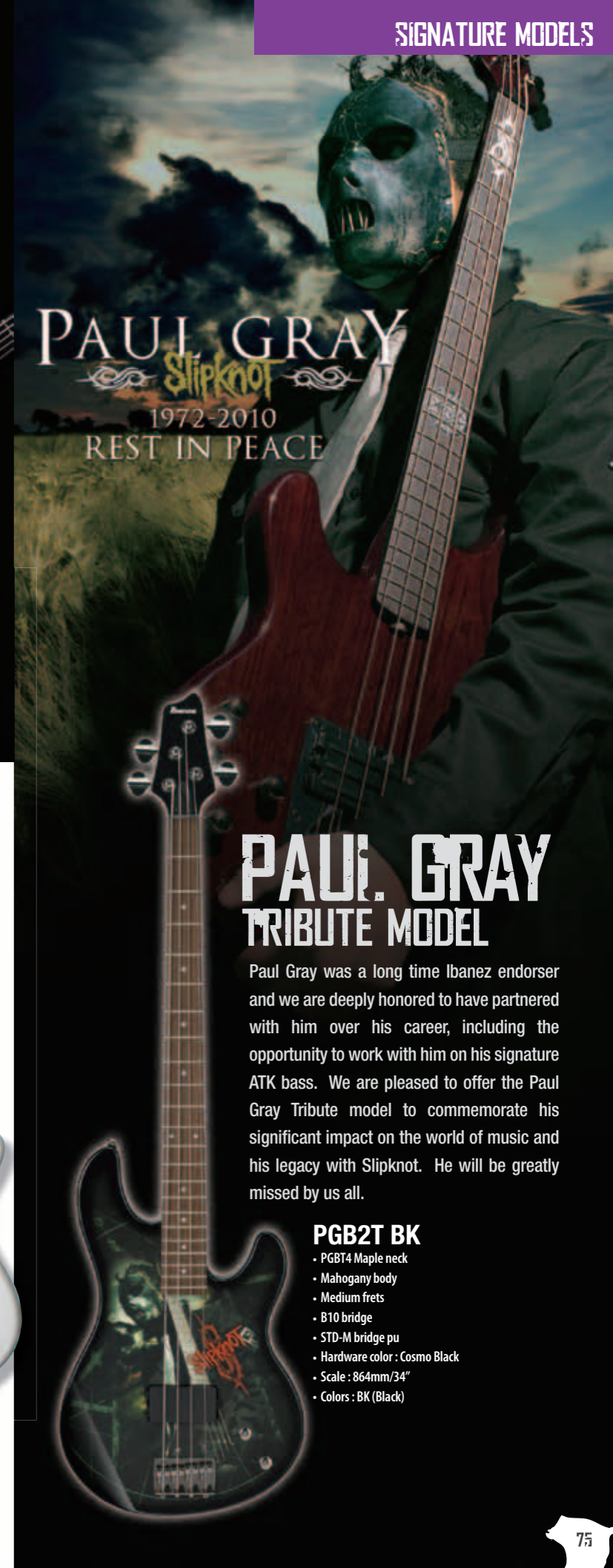

PAUL GRAY
Slipknot
1972-2010
REST IN PEACE

PAUL GRAY TRIBUTE MODEL

Paul Gray was a long time Ibanez endorser and we are deeply honored to have partnered with him over his career, including the opportunity to work with him on his signature ATK bass. We are pleased to offer the Paul Gray Tribute model to commemorate his significant impact on the world of music and his legacy with Slipknot. He will be greatly missed by us all.

PGB2T BK

- PGBT4 Maple neck
- Mahogany body
- Medium frets
- B10 bridge
- STD-M bridge pu
- Hardware color : Cosmo Black
- Scale : 864mm/34"
- Colors : BK (Black)

JUMPSTART

When we say "Everything you need to get out and gig," we mean everything—amp, axe, accessories. All it takes is you and your desire to make your dreams real—to get out of the audience and up on stage where you belong.



GRG121EXJ -Jumpstart-

Features GRG electric guitar and Jumpstart Guitar Package Accessories.

Amplifier
15 watt dedicated guitar amp w/reverb

Package Accessories

- Electronic Tuner
- Gig Bag
- Guitar Strap
- Picks
- Accessories Pouch



GRX70DXJ -Jumpstart-

Features GRX electric guitar and Jumpstart Guitar Package Accessories.

Amplifier
10 watt dedicated guitar amp

Package Accessories

- Electronic Tuner
- Gig Bag
- Guitar Strap
- Picks
- Accessories Pouch



GSA6J -Jumpstart-

Features GSA electric guitar and Jumpstart Guitar Package Accessories.

Amplifier
15 watt dedicated guitar amp w/reverb

Package Accessories

- Electronic Tuner
- Gig Bag
- Guitar Strap
- Picks
- Accessories Pouch



GSR190J -Jumpstart-

Features GSR electric bass and Jumpstart bass Package Accessories.

Amplifier
15 watt dedicated bass amp

Package Accessories

- Electronic Tuner
- Gig Bag
- Bass Guitar Strap
- Picks
- Accessories Pouch



AMPLIFIERS EFFECTS ACCESSORIES

GREAT TONE STARTS WITH GREAT GEAR SHAPE YOURS WITH IBANEZ



Boost Switch

Turning the boost switch on increases gain by 6db. This function gives players a thicker Tubescreamer sound.

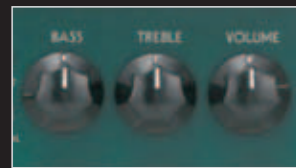

Tone Control

The tone control gives players access to the natural clean sound and biting crunch only possible with tube amps. A simple 2-band control is provided.



Wattage Selection

Switching between 15W mode and 5W mode is possible using the switch located on the back of the amp. Even when using the 5W mode for practicing at home or in other quieter playing situations, players can still get plenty of the warm Tubescreamer sound.



TUBE SCREAMER AMPLIFIER

For all the warm tube overdrive punch and crunch you'll ever need!

The Ibanez TUBESCREAMER is one of the best overdrive pedals ever produced. The TSA15H tube amp features a true TUBESCREAMER circuit, and while the TSA112C speaker cabinet is designed to match the TSA15H, featuring the popular CELESTION Seventy 80 speaker. Ibanez TUBESCREAMER amps can create natural clean sounds, fat crunch tones, and even warm smooth overdrive tones with the modified TS9 circuit built right into the amp.



TSA15H

Guitar Amplifier Head

- output power 15W/5W
- controls Boost/Normal Switch, Tubescreamer On/Off Switch, Master Volume, Bass, Treble
- i/o's Tube Screamer Section: Overdrive, Tone, Level; Guitar Input, Foot Switch Jack, Effect Loop (Send/Return); Speaker Output (2x4Ω, 2x8Ω, 1x16Ω)
- size 368(W) x 172(H) x 200(D) (mm)
- weight 7.6kg

TSA112C

Speaker Cabinet

- power handling 80W
- speaker 12" Celestion Seventy 80
- i/o's Input 8Ω
- size 460(W) x 410(H) x 305(D) (mm)
- weight 13.0 kg



IFS2G

Footswitch

This latching footswitch with green housing is made especially for the TSA15H.

The Ibanez Tubescreamer has long been the name people think of first with overdrive pedals, and TSA tube amps come with the legendary Tubescreamer circuit built in. Players can enjoy the warm and familiar overdrive sound of the Tubescreamer any time they want.



wholetone

The Ibanez WT80 was made to produce clean sounds. With 80W of power and a 15-inch speaker, players can get clean sounds with plenty of volume. The DSP-based precision limiter makes it possible to raise the volume without the sound distorting.

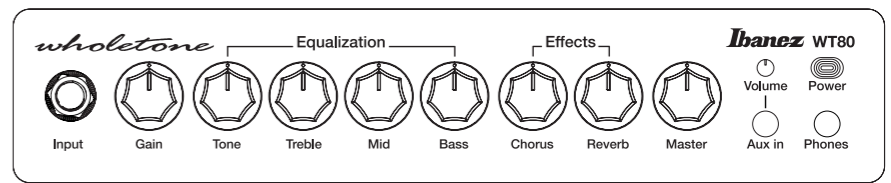

3 band EQ+Tone

Aside from its 3 band EQ, an additional tone control allows you to adjust the overall tonal character of the amp.



Chorus and Reverb Effects

Chorus and reverb controls allow you to add depth and space to your sound. The Aux inputs separate volume control allows you to blend just the right amount of backing tracks with ease.



WT80

Guitar Amplifier

- output power 80W@4Ω
- speaker unit Special Tuned 15" Speaker
- controls Gain, Bass, Mid, Treble, Tone, Master-Volume, Aux-Volume, Chorus, Reverb
- i/o's Input, Aux Input, Headphones Out with Stereo FX
- cabinet Ported Cabinet
- size 440(W) x 366(D) x 500(H) (mm)
- weight 17.6kg



Tone Blaster

TBX150H 150W Guitar Amplifier Head

- output power 150W@4Ω
- controls Normal Channel - Overdrive Switch, Gain, Bass, Middle, Treble, Volume, Reverb Level
Hot Channel - X Mode Switch, Gain, Bass, Middle Frequency, Middle Level, Treble, Volume, Reverb Level, Channel Switch, Hue Input, Send, Return, 2 x Speaker Output, Footswitch 1 & 2
- i/o's W/Accessory Box
- cabinet 636(W) x 252(D) x 259(H) (mm)
- size 14.1kg
- weight

IS412CS Speaker Cabinet

- speaker unit 4 x 12" Ibanez IS1216G
- power handling 320Wrms/640Wmax
- i/o's 2 x Input (4Ω&16Ω)
- cabinet IS412CA : Traditional Angled
IS412CS : Straight Front Angled
- size 707(W) x 334(D) x 755(H) (mm)
- weight 34.0kg

*Also Available IS412CA w/Angled Front

The new generation Tone Blaster X series amps were designed and created to answer the needs of today's guitarist. The parametric mid EQ allows you to dial in any tone you're looking for in an instant. The exclusive X mode allows you to get monstrously heavy and lets you cut through the din of the loudest rhythm section. The gain control in the normal channel can be dialed down to give you anything from a clean jazz tone to a crunchy, slightly overdriven rock'n roll tone. Plug in and express yourself with TBX.



TBX150R 150W Guitar Amplifier

- output power 150W@4Ω
- speaker unit 2 x 12" Ibanez IS1208G
- controls Normal Channel - Overdrive Switch, Gain, Bass, Middle, Treble, Volume, Reverb Level
Hot Channel - X Mode Switch, Gain, Bass, Middle Frequency, Middle Level, Treble, Volume, Reverb Level, Channel Switch, Hue Input, Send, Return, Speaker Output, Footswitch 1 & 2
- i/o's Closed Back
- cabinet 668(W) x 274(D) x 500(H) (mm)
- size 24.5kg
- weight



X Mode/Channel
The X mode/channel emphasizes tighter low end and a unique tonality in the midrange, which increases sustain and harmonics.

TBX30R 30W Guitar Amplifier

- output power 30W@8Ω
- speaker unit 10" Ibanez IS1008G
- controls Normal Channel - Gain, Volume, Channel Switch
X Channel - Gain, Volume
EQ - Bass, Middle Frequency
Middle Level, Treble, Reverb Level
Input, CD/MP3 In, Footswitch, Headphones
- i/o's Open Back
- cabinet 440(W) x 222(D) x 413(H) (mm)
- size 8.3kg
- weight



IBZ

These Ibanez practice amps provide players with full-on guitar and bass sound.



IBZ15GR 15W Guitar Amplifier

- output power 15W @ 4Ω
- speaker unit 8" Speaker
- controls Normal Channel - Volume, Channel Switch
Distortion Channel - Gain, Volume
Bass, Middle, Treble, Reverb
Input, Aux Input, Headphones Out
- i/o's Closed Back
- cabinet 355(W) x 210(D) x 340(H) (mm)
- size 6.1kg
- weight

With a high output of 15W and an 8" specialized speaker, the IBZ15GR provides an intense sound. In addition to full-fledged distortion, a control for reverb has also been added.



IBZ10G Guitar Amplifier

- output power 10W@4Ω
- speaker unit 6.5" speaker
- controls Overdrive On/Off Switch, Gain
Bass, Treble, Volume
Guitar Input, Headphone, CD Input
- cabinet Closed Back
- size 274(W) x 200(D) x 313(H) (mm)
- weight 5.3 kg

This amp reproduces a heavy sound using a closed-back cabinet and a 6.5" Power Jam speaker. It comes with simple Bass / Treble control for producing various tones as well as a CD input.



IBZ10B Bass Amplifier

- output power 10W@4Ω
- speaker unit 6.5" speaker
- controls Bass, Middle, Treble, Volume
Bass Input, Headphone
Closed Back
- cabinet 274(W) x 205(D) x 313(H) (mm)
- size 5.1 kg
- weight

The IBZ10B features a closed-back cabinet and 6.5" Power Jam speaker for producing real bass sound. The 3-band EQ allows players access to a variety of sounds, and the amp also comes with a CD input.

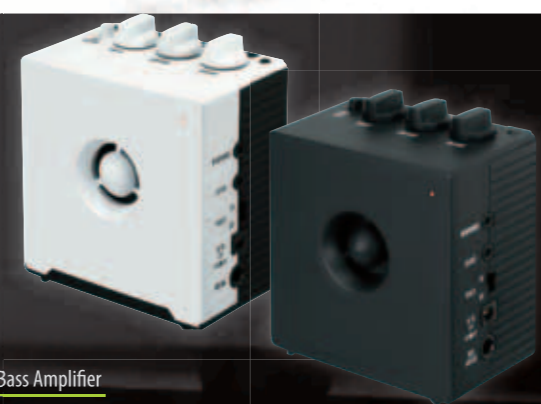

DAG1 Desktop Guitar Amplifier

- output power 1.6W @ 8Ω
- speaker unit 3" speaker
- controls Distortion On/Off Switch,
Treble, Contour, Volume
Guitar Input, Headphone, CD Input
- i/o's 102(W)x116(H)x63(D) (mm)
- size 9V battery (sold separately)
- power source 12V AC Adapter included

DESKTOP AMPS

These compact amps are great for placing on a desk or taking outside. You can also connect them with a digital audio player or other audio device to jam along with your favorite music. In addition, the Hot switch gives you distortion for a guitar or a mid boost for a bass with just the push of a button.

DAB1 Desktop Bass Amplifier

- output power 1.6W @ 8Ω
- speaker unit 3" speaker
- controls Mid-Boost On/Off Switch,
Treble, Contour, Volume
Bass Input, Headphone, CD Input
- i/o's 102(W)x116(H)x63(D) (mm)
- size 9V battery (sold separately)
- power source 12V AC Adapter included

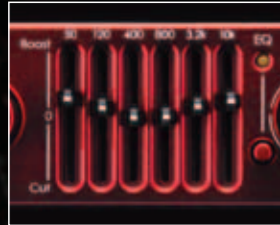

6 Band Graphic EQ

Promethean series amps feature 6-band Graphic EQ that allows you to make precise tonal adjustment in any type of environment. Each frequency is carefully selected to be the most demanded by bass players. The 6-band EQ can be bypassed by a selected switch.



Vibe Control

Control tonal character from creamy vintage sounds to modern sounds. Also, the On/Off push switch allows you to change playing character, from walking to picking and/or slapping, instantly. (On/Off can be controlled by optional IFS2X footswitch.)



Aux/Phones

The included aux input allows you to play along with a connected MP3 or CD player. With headphone out, it's great for bedroom jam sessions or sound check at rehearsal.



Line Out

The balanced XLR output sends a balanced signal to the mixing console and/or main PA system in any live or studio situation. Pre- or Post EQ switchable and GND Lift switch-equipped along with switchable level control to avoid ground loops with other connected equipment.

SPEAK LOUD AND CARRY A SMALL AMP
promethean
IBANEZ BASS AMPLIFIERS

One might never imagine that a small amp could produce big sound, but in terms of the Ibanez Promethean Bass amp series, that is not the case. The Promethean series amp is designed for busy working musicians who travel around from one venue to the next. Within its compact body, the Promethean features CRITICAL functions in order to deal with various situations and requirements in a live environment. It also gets LOUD!!! The working musician has it easy with the Promethean amp, a dependable workhorse of an amp.



Detachable Amp Head (P5110/P5210)

The P5110 and P5210 amp head can be easily detached without any tools. Due to its compact size, it's efficient to take it out anywhere you need to go.

P5110

Bass Combo Amplifier

- output power 250W@8Ω/500W@4Ω
- speaker unit 10" Ceramic Speaker, Dome Tweeter
- controls Mute Switch, Gain, Low/High Control, 6 Band Graphic EQ, Vibe Control, Master Volume
- i/o's Input, Aux Input, Phones Out, Tuner Out, Balanced Line Out (XLR), Footswitch Jack (Mute/Vibe)
- cabinet Ported cabinet w/Tilt-up bar
- size 326(W) x 332(D) x 360(H) (mm)
- weight 12.5kg

The P5110 delivers 250W@8Ω while using individually. Along with the P110C speaker cabinet, it delivers 500W@4Ω in total.



P5210

Bass Combo Amplifier

- output power 500W@4Ω
- speaker unit 2 x 10" Ceramic Speaker, 2 x Dome Tweeter
- controls Mute Switch, Gain, Low/High Control, 6 Band Graphic EQ, Vibe Control, Master Volume
- i/o's Input, Aux Input, Phones Out, Tuner Out, Balanced Line Out (XLR), Footswitch Jack (Mute/Vibe)
- cabinet Ported
- size 332(W) x 376(D) x 711(H) (mm)
- weight 24.8kg

A bass combo amplifier with 2 x 10" speakers and 500W. It performs perfectly in any situation regardless of the venue, from a small pub to a larger club situation. The head is detachable from cabinet, so you can carry it around and use just the head.



IFS2X

Footswitch

Latching footswitch with metal housing for use with the P500H and P5110. (The IFS2X is not included and is sold separately)



P500H

Bass Amplifier Head

- output power 250W@8Ω/500W@4Ω
- controls Mute Switch, Gain, Low/High Control, 6 Band Graphic EQ, Vibe Control, Master Volume
- i/o's Input, Aux Input, Phones Out, Tuner Out, Balanced Line Out (XLR), Footswitch Jack (Mute/Vibe)
- size 280(W) x 265(D) x 57(H) (mm)
- weight 2.9kg

P5115K

Bass Combo Amplifier

- output power 500W @ 4Ω
- speaker unit 15" Speaker w/Horn Tweeter
- controls Same as P500H
- i/o's Same as P500H
- Cabinet Tilt-back, Ported
- size 475(W) x 400(D) x 520(H) (mm)
- weight 18.1kg

A bass combo amplifier with 1 x 15" speaker and 500W. The tilt-back style cabinet allows you monitoring your sound with easily.



BGP511

Carry Bag

Bag for P5110. (The BGP511 is not included and is sold separately)



P115CC Speaker Cabinet

- 250W
- 15" Speaker
- Horn Tweeter
- 1/4" jack x2
- Ported cabinet
- 620(W) x 400(D) x 470(H) (mm)
- 24.5kg



P410CC Speaker Cabinet

- 250W
- 4x10" Speaker
- Horn Tweeter
- 1/4" jack x2
- Ported cabinet
- 620(W) x 400(D) x 620(H) (mm)
- 33.2kg



P110C Speaker Cabinet

- 250W
- 10" Neodymium Speaker
- Dome Tweeter
- SPEAKON® Combo Jack
- Ported cabinet w/Tilt-up bar
- 326(W) x 325(D) x 460(H) (mm)
- 9.5kg



P210KC Speaker Cabinet

- 250W
- 2 x 10" Speaker
- Horn Tweeter
- 1/4" jack x2
- Tilt-back, Ported cabinet
- 620(W) x 380(D) x 465(H) (mm)
- 22.3kg

*SPEAKON® is a registered trademark of Neutrik AG

Sound Wave



The SW amps are tilt-back style practice amps. Three types of SW amps are provided: for players looking for a big sound, players looking for a small amp that has the same number of functions as higher-grade amps, and players looking for the biggest speaker possible at the lowest possible price. With a tilt-back design that aligns the amp at just the right angle with your standing position and with the limiter that provides precise control to prevent unfavorable distortion, SW amps are truly worthy of being called the absolutely best practice amps.

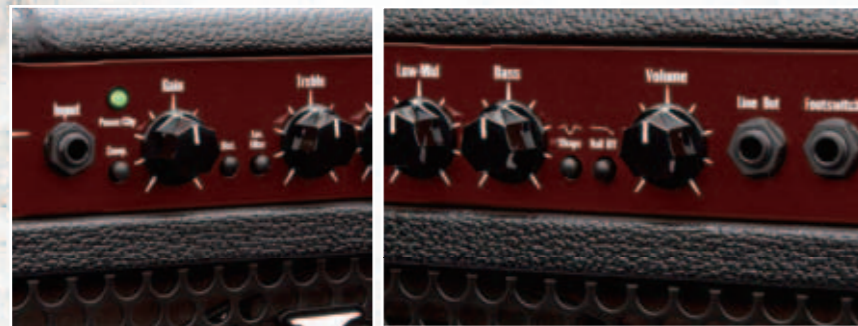
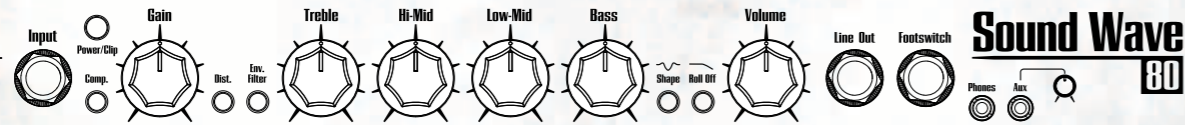

Effects (SW80, SW35)

SW amps feature an envelope filter for creating unique sounds, analog distortion that has been optimized for use with basses, and a compressor. Both the envelope filter and distortion can be controlled using a footswitch. Both mid-shape and roll-off controls are included with SW amps.



SW35

Bass Combo Amplifier

- output power 35W @ 8Ω
- speaker unit 10" Speaker
- controls Gain, Bass, Low-Middle, High-Middle, Treble, Volume, Compression Switch, Shape Switch, Roll Off Switch, Distortion Switch (Footswitchable), Envelope Filter Switch (Footswitchable)
- i/o's Input, Aux Input, Line Out, Headphones Out, Footswitch Jack
- cabinet Tilt-back, Closed
- size 445(W) x 350(D) x 440(H) (mm)
- weight 13.9kg

SW15

Bass Combo Amplifier

- output power 15W @ 4Ω
- speaker unit Special Tuned 10" speaker
- controls Bass, Middle, Treble, Volume
- i/o's Input, Aux Input, Headphones Out
- cabinet Tilt-back, Closed
- size 340(W) x 280(D) x 370(H) (mm)
- weight 6.9kg

SW80

Bass Combo Amplifier

- output power 80W @ 4Ω
- speaker unit 15" Speaker with Piezo Tweeter
- controls Gain, Bass, Low-Middle, High-Middle, Treble, Volume, Compression Switch, Shape Switch, Roll Off Switch, Distortion Switch (Footswitchable), Envelope Filter Switch (Footswitchable)
- i/o's Input, Aux Input, Line Out, Headphones Out, Footswitch Jack
- cabinet Tilt-back, Ported
- size 540(W) x 400(D) x 550(H) (mm)
- weight 20.2kg

TROUBADOUR

ACOUSTIC GUITAR AMPLIFIER

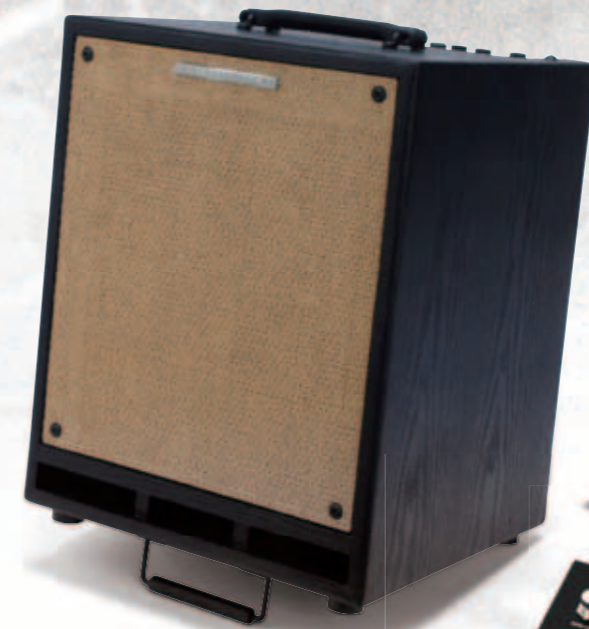

T80

80W Acoustic Guitar Amplifier

- output power 80W
- speaker unit 2x8" Speaker (with tweeter)
- controls Input-Volume, Treble, Middle, Bass, Chorus, Reverb, Notch-Filter, Master-Volume, Aux-Volume
- i/o's Input, Input / XLR-In, Aux Input, Headphones Out with Stereo FX, Line-Out(Left), Line-Out(Right), Footswitch-Input
- Footswitch Chorus, Reverb, Notch Filter
- cabinet Phase Invert, Mute
- size Ported w /Tilt-up bar
- weight 360(W) x 352(D) x 480(H) (mm) 14.6kg

Ibanez Troubadour amps provide the wide variety of relaxed feels found with handcrafted boutique amps. These amps, made especially for acoustic guitars, are deeply infused with natural tone. The Troubadour lineup includes 10W (T10), 20W (T20), and 35W (T35) models providing portability, and an 80W (T80) model that provides the utmost in sound quality. With the Troubadour, find the acoustic sound you've always been looking for.



T10

10W Acoustic Guitar Amplifier

- output power 10 w
- speaker unit 6.5" Speaker
- controls Mid Shape, Hue
- i/o's Chorus w/Speed Control
- cabinet Internal Limiter, Volume
- size Guitar Input, CD/AUX Input
- weight Headphones/Line Out

T20

20W Acoustic Guitar Amplifier

- output power 20 w
- speaker unit 8" Coaxial Speaker
- controls 3 Band Eq w/Sweepable Mid
- i/o's Natural Mode/Shaped Mode Switch
- cabinet Chorus w/Speed Control, Reverb,
- size Internal Limiter, Mic Channel w/Tone Control
- weight CD/AUX Input, Headphones/Line Out

T35

35W Acoustic Guitar Amplifier

- output power 35 w
- speaker unit 10" Coaxial Speaker
- controls 3 Band Eq w/Sweepable Mid
- i/o's Natural Mode/Shaped Mode Switch
- cabinet Chorus w/Depth & Speed Control, Reverb
- size Internal Limiter, Mic Channel w/Tone Control
- weight Mic Volume, Guitar Volume, Master Volume



Dual Mode Switch (T35, T20)

The Natural Mode produces a true, natural guitar sound that is ideal for finger-style playing, while the Shaped Mode gives players a dynamic sound with strong highs and lows that is great for strumming.

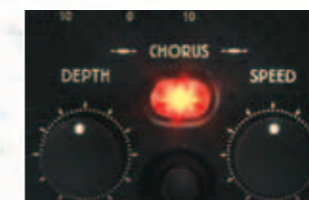

Chorus, Reverb

All Troubadour amps include a chorus effect for producing natural and beautiful tones, while the T80, T35 and T20 also come with a reverb effect for a wider variety of sound options. The T80 also features a DSP-based preamp for cleaner sounds and higher sonic quality.



Mic Input, CD/AUX Input

Troubadour amps include both a guitar and mic input, each with its own separate preamp to allow for separate detailed settings. In addition, the CD/AUX input can be used to connect a CD or digital audio player so you can play along with a backing track.



Notch Filter

The T80 comes with notch filter, phase invert, and mute functions. With the included footswitch, the notch filter range can be changed to prevent feedback without having to change your performance position.



JD9 Distortion

The Ibanez JD9 produces a unique sound reminiscent of a high-grade handcrafted effects pedal. From piercing distortion to the warm crunch of a tube amp, this pedal features a wide variety of drive control options. The mid control is capable of producing a vast range of sounds from American hard rock to British heavy metal. The pedal is also designed with True Bypass to keep changes in sound when the pedal is off to a minimum.



BB9 Booster

The Ibanez BB9 is a booster that provides a fat bottom end and a powerful sound. This pedal is designed to help clean tones reverberate even more and bring more intensity to a player's sound. Combination with a distortion pedal allows for creation of a wide variety of tone colors, and the pedal is also equipped with True Bypass.

9series EFFECTS



FL9 Flanger

Same circuitry and coveted flanging effects of the original '80s unit but constructed to closer tolerances for more consistency from unit to unit. If you've been hunting for an original but couldn't find one, or couldn't afford a high asking price, now's your chance to bag this '80s favorite. Might even be better than the original.



DC3&DC5

Splitter cords for powering 3 or 5 pedals from one adapter.



CS9 Stereo Chorus

When it comes to compact effects, nine is the magic number. By popular demand (and the understandably escalating prices of the originals), Ibanez has reissued its popular CS9 chorus featuring the original circuitry. If you missed out on getting one of these classics the first time around, now is your chance.



AD9 Analog Delay

The Ibanez AD9 Analog Delay Effect Pedal uses a compander with pre- and de-emphasis for an exceptionally clean delay. Time and level controls allow mixing between dry and delayed signals. Repeat control lets you adjust the number of repeats without runaway. 2 outputs enable dry and delayed signals to be routed separately.

For more than a quarter century, the Tubescreamer has continued to captivate players as the first name in overdrive pedals. With that same distinctive sound and high quality esteemed even by pro players, Ibanez compact effects pedals set the new standard in guitar sound.



TUBE SCREAMER

TS808HW Hand-Wired Tubescreamer

The Ibanez Tubescreamer, in its many versions and forms, can be found on pedal boards in every corner of the globe, on arena stages and in small studios and bedrooms. Its warm overdrive is a sound many players, from advanced to beginner, could never do without. Now, it gets even better with the release of the TS808HW, a Hand-Wired deluxe Tubescreamer built with the pro musician in mind.

Encased in a special, heavy duty metal box, the TS808HW is Hand-Wired with select JRC4558D chips (same as the revered and often imitated TS808) and uses Japanese high-end MOGAMI OEC cable (AWG21). Equipped with True Bypass, this Tubescreamer sends pure guitar excitement to your amplifier with no tonal loss whatsoever. This is, by far, the most evolved Tubescreamer ever created.



TS9B Bass Tubescreamer

The TS9B is equipped with controls to allow bassists to produce the sound they want while still maintaining the feel of the Tubescreamer. Experimenting with the mix and tone controls allows for creation of a limitless number of sounds. Players can get a tight, fuzzy sound with mix control or a mid-scooped, funky sound with 2-band control.



TS808 The Original Tubescreamer

Modeling and boutique pedal makers have copied the smooth and full tone of this pedal countless times. Now you can have Ibanez's faithful reissue at a price that doesn't break the bank. The reissue features the same JRC4558D IC chip and analog circuitry as the original. Controls include overdrive, level, and tone controls.



TS9 Tubescreamer

The Ibanez TS9 Tubescreamer is a reissue that's just like the original in so many ways. Same housing, same famous seasick-green paint, and the same cranking overdrive that made the original one of the all-time classic pedals. Guitar Player called it the best. Plug it in. Crank it up. You'll hear what all the fuss is about. Tone, drive, and level controls.



TS9DX Turbo Tubescreamer

The Ibanez TS9DX Turbo Tubescreamer Effects Pedal features the same circuit as a TS9 Tubescreamer and also offers 3 new settings for increased low end crunch: +, Hot, and Turbo.

TUBE KING

While the tube in many 9-volt tube-overdrive pedals merely functions like a filter, the TK999 Tube King and its crown jewel 12AX7 tube get genuine high voltage, just like a tube preamp. The result? The Tube King can make any solid-state amp sound just like a tube amp, with massive, tight overdrive/distortion.

TK9990D Tube King Overdrive

- Genuine High Voltage Tube Overdrive
- 3 band EQ with presence
- Gain and level controls
- Hi/Lo input switch
- AC Adapter included



TK999HT Tube King Distortion

- Genuine High Voltage Tube Distortion
- Actual 12AX7 Tube
- Active EQ plus Presence Switch
- VOID Control
- AC Adapter included



Range switch : Guitar 350Hz - 2.2kHz
Bass 175Hz - 1.1kHz
Depth control : +6 - +12dB



WD7JR

Weeping Demon Junior

A more affordable version of our WD7 pedal, the WD7JR presents a high quality wah-wah pedal at a great price. Activates with minimal pedal pressure. Auto Off Delay control allows you to delay the end of wah-wah effect after your foot leaves the pedal, for smooth transition and phrasing. Features a maintenance-free optical sensor – no need to worry about producing unwanted noise from the volume pot. Also includes Level control for volume adjustment.



WD7JR/Auto-Off Delay

Adjusts the time delay from when the pedal is returned until the effect switches off. Turning this clockwise will increase the time delay, preventing the effect from turning off while you are operating the pedal. Turning this counterclockwise will make the effect turn off more quickly, so that it will turn off immediately when you return the pedal.

WD7

Weeping Demon

The Ibanez WD7 Weeping Demon Wah Pedal will have your audience screaming for more with its shrieks, cries, wails, and seductive siren songs. Among its features are spring and normal footboard action, selectable wah range, and fine tuning controls.



WD7/Auto-Off Delay

In the AUTO SWITCH mode, you can set the effect-off either on standard instant off when the pedal is returned to the full upright position or a delayed-off by turning the control clockwise.



WH10V2

WH10V2

Classic Wah Pedal

The upgrade you will notice is the die-cast metal construction, replacing the original plastic case. Feel free to dance on this sucker now—it can take anything you dish out.

The WH10V2 features the same multiple feedback opamp circuit as the original, a feature rarely found in today's wah pedals. It also has a depth knob to control to level of the wah effect and a dry out for mixing a dry signal with the wah sound. The WH10V2 has a unique tone character setting it apart from all traditional wah pedals, as well as some modern tweaks so your sound keeps changing with the times.

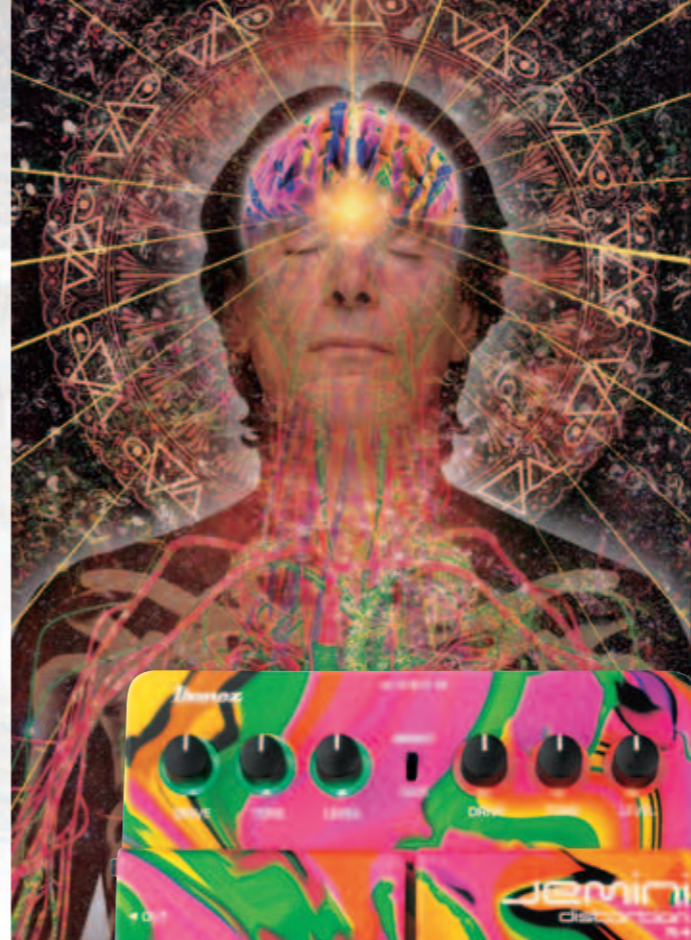

AIRPLANE FLANGER

Paul Gilbert Signature Pedal Effect Flanger

The Paul Gilbert Signature AF2 AIRPLANE Flanger is two pedals in one package. One section is a traditional chorus flange (TAXI); the other is an insane (TAKEOFF) flange (hence the "AIRPLANE" moniker), which provides virtuoso guitarist Paul Gilbert's own "Crazy Flange" sound. Time to buckle up. The AF2 features Manual (delay time), Speed (modulation speed), Range (depth of modulation), and Enhance (feedback) controls.

AF2

- Paul Gilbert Signature Flanger "AIRPLANE FLANGER"

- controls
 - TAXI : Flange/Chorus Type Modulation Effect
 - TAKEOFF : Jet Sound (shifting pitch up and down)
 - MANUAL : Delay Time
 - SPEED : Modulation Speed
 - RANGE : Depth of Modulation
 - ENHANCE : Feedback
 - EFFECT ON/OFF Switch
 - TAXI/TAKEOFF Switch
 - INPUT/OUTPUT (Mono)
- i/o's
- size
 - 180(W) x 134(D) x 65(H) (mm)
- power source
 - Operates with a DC 9V AC Adapter



Jemini

dual distortion reality

Steve Vai's Signature Distortion Pedal with overdrive and distortion in one package. Featuring a rigid aluminum case, magnificent LED lights around the knobs, and a unique multicolor case with Vai logo rubber foot pedals. The JEMINI's meant to be seen and heard.

JEMINI

- Steve Vai Signature Distortion "JEMINI"

- controls
 - Distortion A / B, DRIVE, TONE, LEVEL
 - LED BRIGHT/SAVE
 - INPUT / OUTPUT
 - 170(W) x 140(D) x 58(H) (mm)
- power source
 - Operates with a DC 9V AC Adapter or 9V Battery



LED Lit Controls

Each side includes drive, tone and level controls with LED indicators around each control and a LED bright/save control switch for daytime use or saving the battery.



Steve Vai Signature Foot Pedals

Steve's trademark logo is imprinted on the Jemini's foot switches.



Heavy Duty Aluminum Housing

The housing is finished off with Steve's infamous trademark swirl paint job.



TUNERS

When you make 6-string, 7-string and 8-string guitars for players who use all kinds of alternate tunings, you'd better be very serious about tuning. We are. Our wide variety of compact tuners offer strict accuracy, easy operation and our famous Ibanez reliability.



LU30 Pedal Tuner
This tuner features aluminum die-cast housing as well as an easily visible LED display. We put a high priority on creating an easy to see display in a compact size tuner. It fits perfectly even in the limited space available on effects boards. One output of the LU30 is muted when it is turned on.



RU10 Jam Tuner
There is no doubt that tuning is important. However it is just preparation, when your goal is to be playing guitar and having fun. With the Ibanez RU10, Jam Tuner, you can do both without firing up your amp. Besides functioning as a chromatic tuner, the RU10 combines a metronome and the Rhythm Play function that features preset rhythm patterns to play along with. The gain control enables you to produce an amazing, real deal distortion sound out of the built-in speaker, letting you jam right away.

PU20 Clip Tuner
PU10 SL
PU10

Both Ibanez clip tuners, PU20 and PU10, are designed to tune electric and acoustic guitars, basses, violins, banjos, mandolins, and more without interference from ambient room noise. It does it all without the use of wires, microphones or pickups. Tuning in noisy environments is a snap because the unique, flexible clamp actually feels the instrument's vibration instead of relying on sound. PU20 features backlit large LCD display for maximum visibility even in the dark stage. PU10 features the 4 hinges that allow a perfect view of the tuner's LED display from nearly any angle.
* Black and Silver colors are available in PU10.



GU1 Automatic Tuner
GU1 and CU1 have two display modes (Needle & Strobe).
- Needle display mode: the meter moves the same as the tuner ever
- Strobe display mode: the meter goes round and tune
CU1 also has manual tuner mode. The operation is very simple even for beginners.



CU1 Chromatic Tuner



GU40 Automatic Tuner
The colorful GU40 guitar tuner from Ibanez features hands-free tuning. This no hassles auto tuner is fast and accurate and works with guitar, bass or almost anything that shares the same tuning. It even has seven tuning notes for 7-string guitars. The GU40 guitar tuner has a built-in mic for fast and accurate metering.



LU10 Chromatic Tuner
This tuner is designed for electric guitars and basses, as well as acoustic guitars. The clever LU10 is an easy-to-use tuner with an LED display including a large, bright note display. It's very easy to work with.



CU40 Chromatic Tuner
The CU40 chromatic guitar tuner from Ibanez is fast and accurate and works with guitar, bass or almost anything else. The CU40 has a large LCD display, LED 'flat' and 'sharp' guide lights and a built-in mic for fast and accurate metering.



MU40 Metronome Tuner
The dual purpose Ibanez MU40 Tuner/Metronome indicates pitch with both an LCD needle display plus red flat and sharp LEDs plus a green in-tune LED. Designed for electric guitars, basses and acoustic instruments. Built-in metronome with speaker, mute switch, and headphone input. Ideal for teachers and students.

CABLES

Series PSC

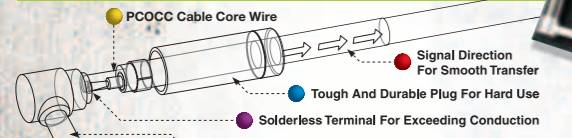

PSC10	
PSC20	
PSC05LL	Patch Cable
PSC08LL	Patch Cable

PCOCC stands for "Perfect Crystal by Ohno Continuous Casting Process". This material has remarkable lower resistance and transfers far more High-Frequency signal than TPC or OFC cables.

CABLE FOR PROFESSIONAL RECORDING AND GIG USE
 * Core : 0.1 x 96 (PCOCC)
 * Shield 1 : Conductive PVC
 * Shield 2 : 0.12 x 16 x 6 Braiding

DSC6	
DSC6L	
DSC10	
DSC10L	
DSC10LL	
DSC15	
DSC15L	
DSC15LL	
DSC20	
DSC20L	
DSC20LL	
DSC25	
DSC25L	
DSC05LL	Patch Cable
DSC08LL	Patch Cable
DSC10BK	Woven
DSC10BL	Woven
DSC10RD	Woven
DSC20BK	Woven
DSC20BL	Woven
DSC20RD	Woven

Series DS



DOUBLE SHIELDED LOW NOISE CABLE
 Double-shielded construction offers pro-quality and durability at standard cable prices.
 * Core : OFC
 * Shield : Braided shield and Aluminum Foil.

Series STC

STC6	
STC10	
STC10L	
STC15	
STC15L	
STC20	
STC20L	
STC25	
STC25L	
STC05LL	Patch Cable
STC08LL	Patch Cable

STANDARD CABLE
 * Core : 0.12 x 20
 * Shield 1 : Conductive PVC
 * Shield 2 : 0.12 x 33 Spiral

Series HAC

HAC10	
HAC10L	
HAC20	
HAC20L	
HAC05LL	Patch Cable
HAC08L	Patch Cable
HAC08LL	Patch Cable

HEAVILY ARMORED CABLE
 Durable, originally designed plug for easy operation
 * Core : 0.12 x 20 OFC
 * Shield 1 : Conductive PVC
 * Shield 2 : 0.12 x 16 x 4 Braiding
 * Plug : PVC original shape

Series 96

NSC6	
NSC6L	
NSC10	
NSC10L	
NSC15	
NSC15L	
NSC20	
NSC20L	
NSC05LL	Patch Cable
NSC08LL	Patch Cable
NSC10BK	Woven
NSC20BK	Woven

PROFESSIONAL GRADE CABLE
 96 micro-standards of silver plated copper core wires offer low impedance and maximum signal transfer.
 * Sure Grip Rubber on Plug
 * Core : 0.1 x 96 (Silver Plated)
 * Shield 1 : Conductive PVC
 * Shield 2 : 0.12 x 16 x 6 Braiding

STRAPS

GS260

Trapper Strap

- 60(mm) width - 1500(mm) length - Original Strap Ends
 Simply slide Trapper Strap ends over the guitar's strap button so the button is lodged tight, just above the Ibanez logo.



GS361 BK

Quick Adjust

- 60(mm) width - 1500(mm) length - Original Grip Adjuster
 The Grip Adjuster enables you to find your most comfortable position with one simple operation. By pressing the lever, the Grip Adjuster slides and changes strap length. Sliding the Grip Adjuster down while holding the lever makes the belt shorter and moves the guitar up, while sliding the Grip Adjuster up, will give you the opposite effect.

Model Number System

Series
PSC : Series PSC
NSC : Series 96
DSC : Series DS
HAC : Series HAC
STC : Series STC

Length	6	6ft/1.83m	25	25ft/7.63m
	10	10ft/3.05m	50	50ft/15.24m
	15	15ft/4.58m	05	0.5ft/15cm
	20	20ft/6.10m	08	0.8ft/25cm

Plug Type
L : Straight - Right Angle
LL : Right Angle - Right Angle
none : Straight - Straight

Speaker Cables



for SPCPP
 * Core : 0.1 x 40 x 5 (Silver plated)
 * Plug : 1/4" x 2
 for SPCNN
 * Core : 0.1 x 28 x 7 (Silver Plated)
 * Plug : Speakon x 2

Plug Type 1/4" - 1/4"		Plug Type NL4FX - NL4FX	
Model#	Length	Model#	Length
SPCPP6	6ft/1.83m	SPCNP6	6ft/1.83m
SPCPP10	10ft/3.05m	SPCNP10	10ft/3.05m
SPCPP25	25ft/7.63m	SPCNP25	25ft/7.63m
SPCPP50	50ft/15.24m	SPCNP50	50ft/15.24m

Microphone Cables

for MCCP
 * Core : 0.1 x 14 x 7 (Silver plated)
 * Shield 1 : Conductive PVC
 * Shield 2 : 0.1 x 16 x 8 Braiding
 * Plug : 1/4" + XLR
 for MCC
 * Core : 0.12 x 20 (x 2 : Stereo)
 * Shield 1 : Conductive PVC
 * Shield 2 : 0.12 x 16 x 6 Braiding
 * Plug : XLR + XLR



Plug Type XLR-1/4"		Plug Type XLR-XLR	
Model#	Length	Model#	Length
MCCP10	10ft/3.05m	MCCC10	10ft/3.05m
MCCP20	20ft/6.10m	MCCC20	20ft/6.10m
MCCP50	50ft/15.24m	MCCC50	50ft/15.24m



PICKS

Basic Color Series

Ibanez covers the basic picks with orthodox shape color. You can choose from 6 kinds of shapes.



Ibanez Classic Design Series

Three of Ibanez' legendary icons are now featured on picks – "Flying Finger," "Tree of Life" and a new design derived the "Ibanez checkmark".



Grip Wizard Series Rubber Grip

Non-slip rubber softly fits your finger. Available on polyacetal, or super hard PPS material picks.

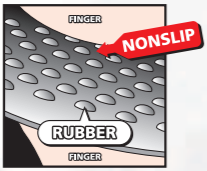

Grip Wizard Series Sand Grip

Dense and wide surface sand provides hard and sure grip.



BASIC COLOR SERIES

Shape	Material	Thickness (mm)	Model No.	Available color	
4	Celluloid	Heavy	1.0	CE4H	BK/PL/SH/WH
4	Celluloid	Medium	0.75	CE4M	BK/PL/SH/WH
4	Celluloid	Thin	0.5	CE4T	BK/PL/SH/WH
6	Celluloid	Heavy	1.0	CE6H	BK/SH/WH
6	Celluloid	Medium	0.75	CE6M	BK/SH/WH
14	Celluloid	Heavy	1.0	CE14H	BK/SH/WH
14	Celluloid	Medium	0.75	CE14M	BK/SH/WH
16	Celluloid	Heavy	1.0	CE16H	BK/SH/WH/HGG/HSC/HTN
16	Celluloid	Medium	0.75	CE16M	BK/SH/WH/HGG/HSC/HTN
20	Celluloid	Heavy	1.0	CE20H	BK/SH
20	Celluloid	Medium	0.75	CE20M	BK/SH
Thumb Pick	Celluloid			CE22L	PL

IBANEZ CLASSIC DESIGN SERIES

Shape	Material	Thickness (mm)	Model No.	Available color	
16	Celluloid/PVC	Heavy	1.0	TL16H	BK/BL/RD/WH/GR/CL
16	Celluloid	Medium	0.75	TL16M	BK/BL/OR/WH/GR/CL
16	Celluloid/PVC	Heavy	1.0	C116H	BK/BL/RD/WH/GR/CL
16	Celluloid	Medium	0.75	C116M	BK/BL/OR/WH/GR/CL
16	Celluloid/PVC	Heavy	1.0	IB16H	BK/BL/RD/WH/GR/CL
16	Celluloid	Medium	0.75	IB16M	BK/BL/OR/WH/GR/CL

GRIP WIZARD SERIES

Shape	Material	Thickness (mm)	Model No.	Available color	
16	Polyacetal w/Rubber Grip	Extra Heavy	1.2	PA16XR	BK/BL/RD/WH
16	Polyacetal w/Rubber Grip	Heavy	1.0	PA16HR	BK/BL/RD/WH
16	Polyacetal w/Rubber Grip	Medium	0.8	PA16MR	BK/BL/RD/WH
16	Polyacetal w/Sand Grip	Extra Heavy	1.2	PA16XS	BK/BL/RD/WH
16	Polyacetal w/Sand Grip	Heavy	1.0	PA16HS	BK/BL/RD/WH
16	Polyacetal w/Sand Grip	Medium	0.8	PA16MS	BK/BL/RD/WH
8	PPS w/Rubber Grip	Heavy	1.0	PS8HR	BK
8	PPS w/Rubber Grip	Medium	0.8	PS8MR	BK
17	PPS w/Rubber Grip	Heavy	1.0	PS17HR	BK
17	PPS w/Rubber Grip	Medium	0.8	PS17MR	BK
30	PPS w/Rubber Grip	Extra Heavy	1.2	PS30XR	BK
30	PPS w/Rubber Grip	Heavy	1.0	PS30HR	BK

Signature Models Steve Vai

Here are the Vai's signature picks, and he won't use anything else.



The Offspring

Be different. The Offspring picks feature the band symbol on one side, and the band name written in Japanese on the other.



Paul Gilbert

This original shaped picks are what THE guitarist with style and speed need.

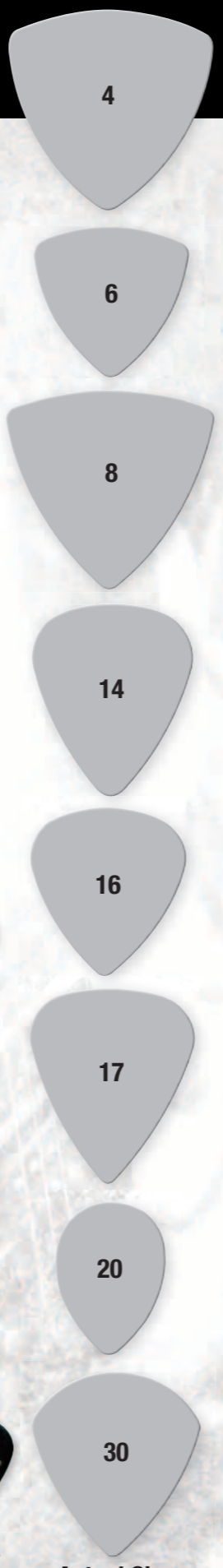

Actual Size

STANDS



ST101

Compact size folding guitar stand for Electric/Acoustic Guitar and Bass.

ST201

Folding guitar stand for Electric/Acoustic Guitar and Bass.

ST301

Tubular guitar stand with folding tripod for Electric/Acoustic Guitar and Bass.

PICK HOLDER



PHI01

Removable, Reusable and Reliable Guitar Pick Holder. The Pick Holder can hold your picks tightly, and easily removed. The Pick Holder is a detachable sticker to be installed on your guitars and basses. The Pick Holder is reusable. If it seems to lose its adhesion, gently wash with water, reapply, and it will be as good as new!



BAGS



Standard Bags

Upgraded standard bags from Ibanez. Improved strap angle, thick shoulder pad and waist belt all combine to make your gear feel lighter than ever.

ISGB501-BK	Bag for El. guitar	ISGBT501-BK	Bag for El. guitar (X,DTT,ICT,STM)
ISBB501-BK	Bag for El. bass		

Double Bags IDGB5-BK

Ibanez double gig bag lets you carry two instruments in one bag. With the wheel on the bottom, you can carry your guitars without any hassle.

IDGB5-BK	Bag for El. guitar
IDBB5-BK	Bag for El. bass



IDBB5-BK

Camouflage Color Bags

Camouflage color versions of standard bag (ISGB501) for El. guitar.



ISGB531-CCT Camouflage City
ISGB531-CSD Camouflage Sand
ISGB531-CGR Camouflage Green

ISGE501-BKO



ISGE501-BKS

Enamel Bags

This gig bag can not only protect your guitar, but it can also make a fashion statement. The colored bags are made of glossy black enamel in two color options of orange or silver Ibanez logo to fit your own personal style. (only for El. guitar)



Deluxe Gig Bags

Sometimes you want something new and different in your gear, even with your gig bag. The IGB601/IBB601 deliver, with loads of pockets (8!!!) to carry what you need – tuner, cables, sheet music, portable players etc. And with the ergonomic-fit strap angle, your traveling load just might feel lighter than ever.

IGB601	Bag for El. guitar
IBB601	Bag for El. bass



Original Bag/IGB611-BBK

Black shoelace design, classy and tough looking. Thick cushioning safely protects your gear.



Ultra-Deluxe Bags

Ultimate gig bag for players on the go. The IGB701/IBB701 securely protects your instruments with extra pads from the body to the neck and with the bottom cover. These bags come with water-resistant exteriors and extra-padded backpack straps.

IGB701-BK	Bag for El. guitar
IBB701-BK	Bag for El. bass



Deluxe Bags w/Backpack

The GBP/BBP bags feature a detachable backpack. Not only is it handy for carrying accessories around along with your guitar or bass, it detaches for typical backpack use.

GBP	Bag for El. guitar
BBP	Bag for El. bass



Gig Bags

IGB101	Bag for El. guitar
IBB101	Bag for El. bass

CASES

No matter which Ibanez guitars or basses you choose, you'll want to protect your precious instrument. Do it in style with an authentic Ibanez hard shell case.

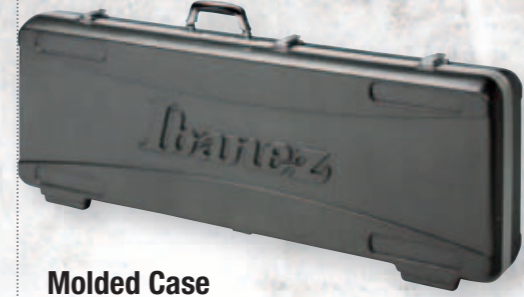

Featherweight Case

F50C	For RG, RGD, RG-7, S, SA, FR, left handed models, RGD-7
-------------	---

Compatible for Left-handed models and 7strings. Made from polyfoam, it is 30% lighter than standard case M100C without losing the toughness and protection of a case.

Molded Case

MP100C	For RG, RGD, RG-7, S, SA, FR, RGD-7 Left handed models
---------------	--

Using the laminated material of ABS and Polycarbonate, it achieves both luxurious appearance and durability.



M100C

M100C



MB5C

M5C

Molded Cases

M100C	for RG, RGD, RG7, S, SA (except 27" scale & left handed models)
MB100C	for SR, SRX, EDB (except left handed models)

Molded Cases

M5C	for RG, RG7, S (except 27" scale & left handed models)
MB5C	for SR (except left handed models)



Wood Cases

AS-C	for AS
GB-C	for AG, AGS
AR-C	for GAX, AR, ART, ARX
AFS-C	for AFS
AF-C	for AF, AK
AM-C	for AMF



Wood Cases

W50RG	for RG, RGD, RG7, RG 8, S, SA (incl. 27" scale & left handed models)
W50DNT	for DN
W50BTB	for BTB, ATK, JTKB
W50SR	for all of SR (incl. left handed models)

IBANEZ ORIGINAL HARDWARE

TREMOLOS	Edge-Zero	Edge-Zero II	ZR	ZR-2	SynchroniZR
ZPS System	✓	✓	✓	✓	
ZPS-FX System					✓
Intonation Adjustment Tool	✓		✓	✓	✓
Stud Lock	✓	✓			
Snap and Hold Arm Socket	✓	Hold Arm Only	Hold Arm Only	✓	✓
Toolless Spring Tension Adjust	✓	✓	✓	✓	✓
Ball-Bearing Pivot			✓	✓	✓
Spring Mute	✓			✓	✓



Edge-Zero / Edge-Zero II

The Edge-Zero has a sharp knife-edge for extremely accurate tremolo playing. This tremolo also uses Ibanez innovations to keep string action constant and the bridge surface smooth. The specially designed arm socket prevents unnecessary wobble from the arm while providing full control over the arm's torque.



ZR-2 / ZR

The ZR-2/ZR is a revolutionary tremolo system. It plays incredibly smooth through the use of its ball bearing mechanism. This also keeps the string action constant, even during the most rigorous tremolo use. The top side features a smooth finish for total hand comfort.

SynchroniZR

The SynchroniZR provides all the innovations of the ZR tremolo in a non-locking design. The one-piece saddle construction minimizes unnecessary wobble and loss of string vibration, and the ultra-light Duralumin tremolo arm keeps the bridge stable while playing. The same intonation and adjustment features of the ZR-2 make this a top-notch choice for any kind of player.



ZPS Zero Point System

Switchable To Floating Trem

The ZPS is the next stage of zero point systems. The addition of two outer springs makes the guitar easier to tune and provides much greater tuning stability. In fact, the other strings will stay in tune even if you break a string. If you prefer a full floating tremolo setup, simply remove the stop bar.

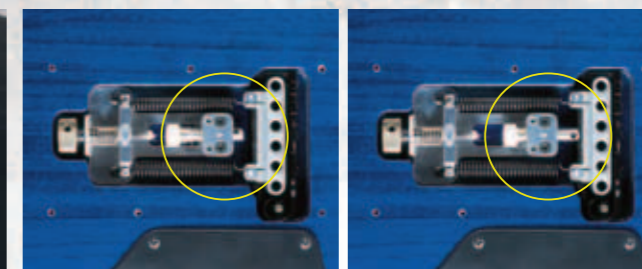

ZPS-FX System

Paired with the SynchroniZR Tremolo, the SV Prestige features the simpler version of the Zero Point System. The ZPS-FX enables switching between Floating/Non Floating by simply turning the knob on the body back.



Spring Mute

Some might think it's inevitable for tremolo springs to resonate, but that's not the case with the Ibanez Prestige. The spring-muting rubber eliminates noise from the spring, providing only clean and cutting sound.



Intonation Adjustment Tool

Just unscrew the built-in intonation adjustment tool from the base and screw it into the bottom of each saddle for quick adjustments.



Ball-Bearing Pivot

Smother than smooth. The ZR tremolo's ball-bearing pivot system allows ultra-smooth arm control. The pivot's precision movement virtually guarantees tuning stability. In the floating position, you can really feel the exceptional smoothness and durability of this significant advance in tremolo technology.



Snap and Hold Arm Socket

Tremolo arm can be snapped into the tremolo and arm torque is easily tightened or loosened by turning the arm-holder adjustment screw cap. No matter what the setting, the arm always feels secure.

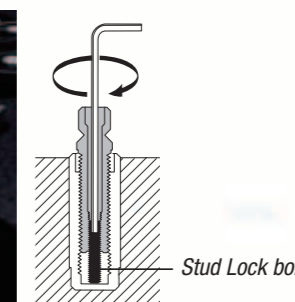
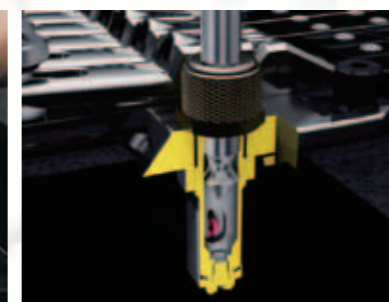

Stud Lock Screws

Lock the stud bolts for maximum string vibration to the body.



Toolless Spring Tension Adjust

Spring tension can be quickly set by thumb. There's no need for any tool.



Tight-Tune Bridge/Tailpiece

Solid as a rock, the Tight-Tune bridge and tailpiece were designed to lock down securely and prevent any kind of wobble or movement. Each saddle is locked into the base plate, and the bridge is anchored by stud bolts into the body of the guitar. Furthermore, the studs are also locked onto the base plate so that the maximum vibration from the string is transferred to the body.

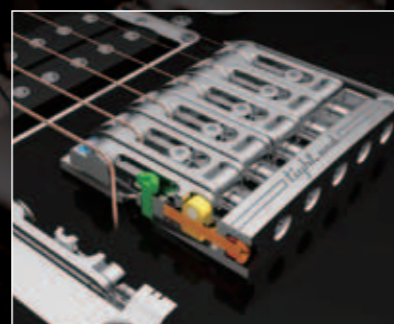

Tight-End Bridge

The Tight-End bridge integrates every aspect of the bridge design in rigidity and accuracy. Saddles are firmly locked onto the base plate for maximum string vibration, and remain perfectly linear during intonation adjustment for the most accurate set up. The saddle height can be adjusted individually by one screw. Also, the top side of the bridge is smooth finished. So if you play hard, the Tight-End bridge will forgive you and your hands.



MR4 Mono-Rail Bridge

The Mono-Rail Bridge is the ultimate in string isolation for bass. Each saddle is independently and securely locked down to the body for maximum vibration transfer and no interference. One screw controls the height of each saddle for easy adjustment.

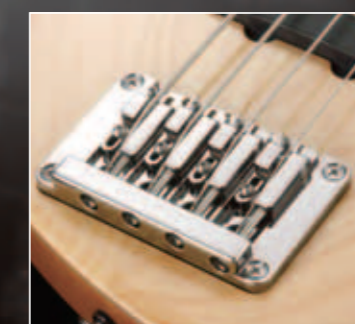

Tight End Bass Bridge

The base plate is firmly locked on to the body with dedicated screws in order to deliver string vibration thorough the bridge to the body without loss. In addition, it installs stainless steel in the saddles and applies the Saddle lock system for its stability and efficient string vibration delivery. The bridge made out of precisely-CNC milled Brass with the massive and solid structure makes the sound totally clear and tight.

H-S-H (5WAY) RG (HSH), JEM, UV, NDM, S (HSH), GRG (HSH)

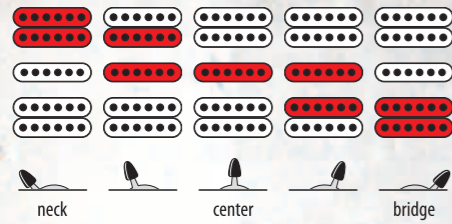

S-S-H (5WAY) GSA

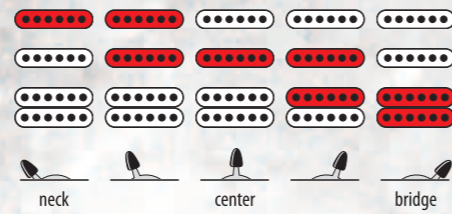

H-S-H (w/True-Duo Blast) SV

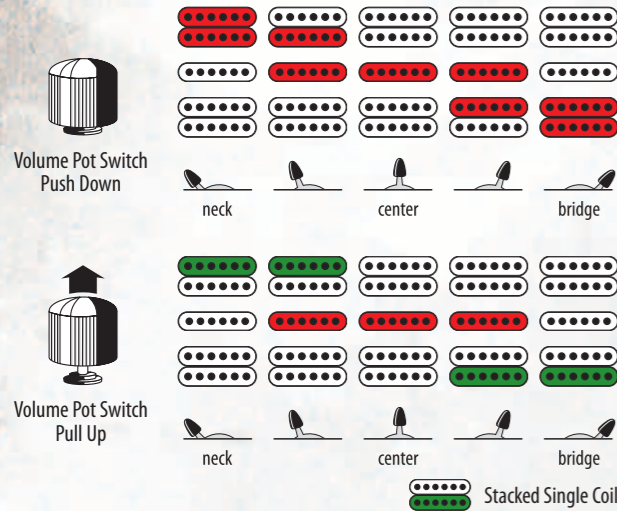

S-S-H (w/True-Duo Bucker) SA (SSH)

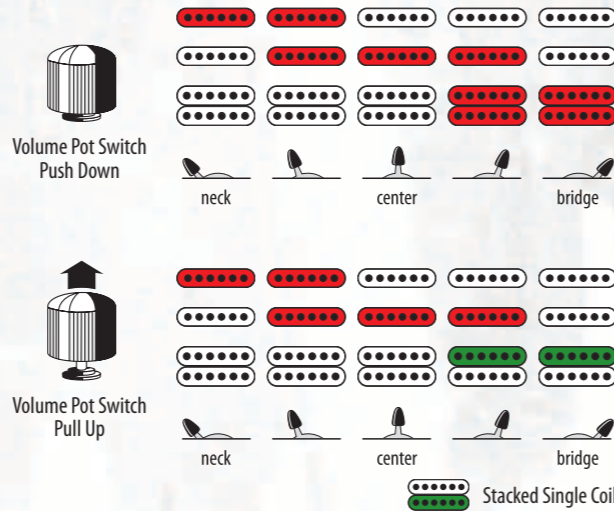

H-S-H (5WAY) EGEN18, EGEN8

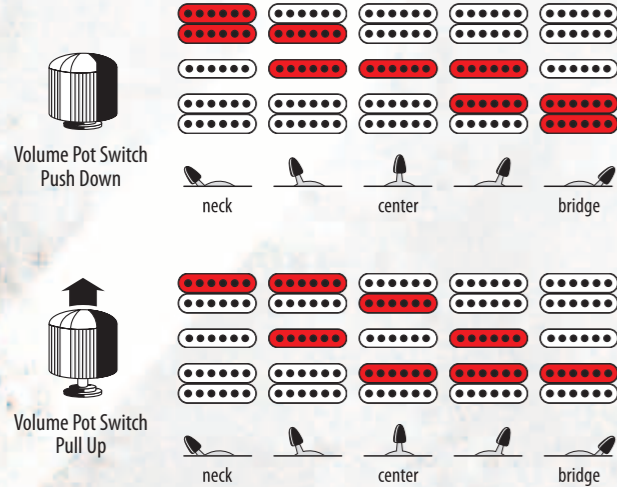

H-H (3WAY) JS2400

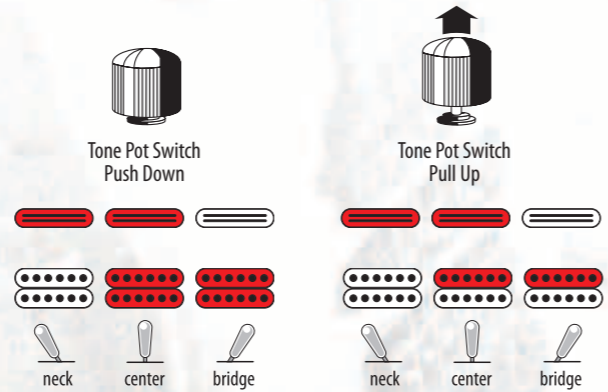

H-H-H (5WAY) AT100CL

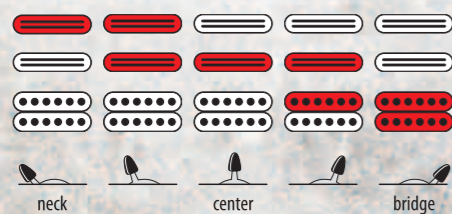

H-H (3WAY) DN, JS1200, JS1000, JS100

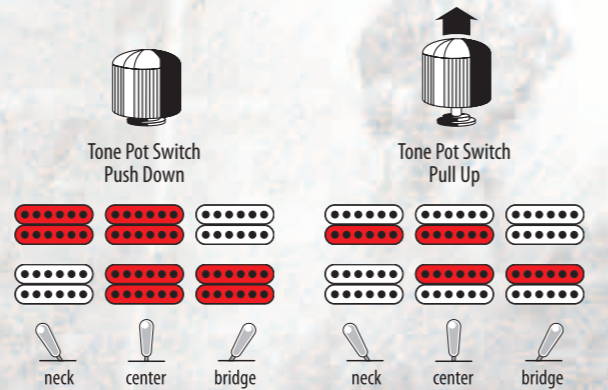

H-H (5WAY) RG (HH), S (HH), SA (HH), RGD Standard

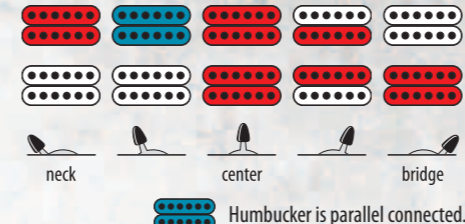

H-H (5WAY) FR

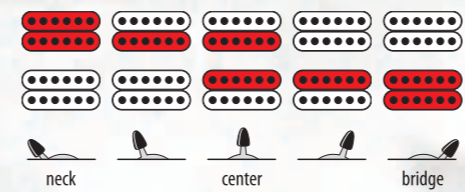

H-H (5WAY) PGM

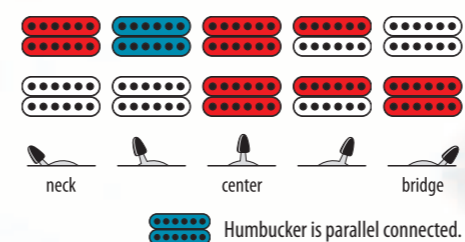

H-H (3WAY)

- ART, ARTCORE, GRGA, DTT, GAX, APEX2, GB, GRGM,
- GRGR, JSM, ARZ, GART, MTM, PM, RG (w/EMG*),
- RGA, RGD Prestige, XPT (HH), ICT, STM, XP300FX

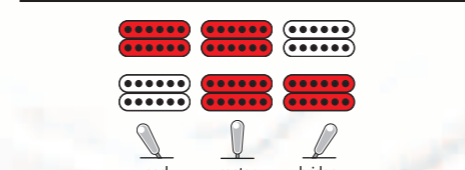

H-H (3WAY) XPT700XH

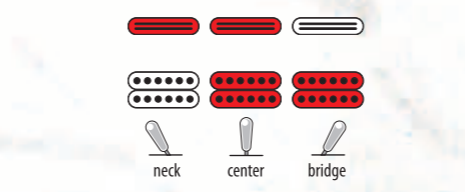

S-H (3WAY) APEX 100

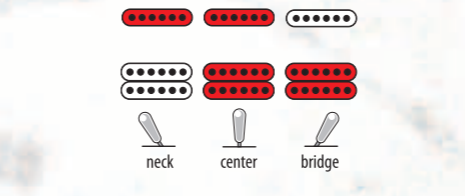

NECK MODEL	SCALE LENGTH	WIDTH AT NUT	WIDTH AT LAST FRET	THICKNESS AT 1ST FRET	THICKNESS AT 12TH FRET	RADIUS
GUITAR NECK DIMENSIONS						
APEX	648mm/25.5"	48mm	68mm	19mm	21mm	430mmR
APEX2	648mm/25.5"	48mm	68mm	19mm	21mm	305mmR
ARTCORE	628mm/24.75"	43mm	57mm	20mm	22mm (at 9F)	305mmR
ART	628mm/24.75"	43mm	57mm	20mm	22mm (at 9F)	305mmR
ARZ	635mm/25"	43mm	57mm	20mm	22mm	305mmR
AT	648mm/25.5"	40.5mm	56mm	21mm	23mm	305mmR
DN	628mm/24.75"	43mm	57mm	20mm	22mm (at 9F)	305mmR
EGEN	648mm/25.5"	43mm	58mm	18mm	20mm	430mmR
GART2	628mm/24.75"	43mm	56mm	20.5mm	23mm	320mmR
GAX1	628mm/24.75"	43mm	57mm	20mm	22mm	400mmR
GB	628mm/24.75"	43mm	57mm	20mm	23mm	305mmR
GRG1	648mm/25.5"	43mm	58mm	19.5mm	21.5mm	400mmR
GRG2	648mm/25.5"	43mm	58mm	19.5mm	21.5mm	400mmR
GRGA	648mm/25.5"	43mm	56mm (at 21F)	20.5mm	23mm	400mmR
GRGM	560mm/22"	42mm	56mm	20.5mm	23mm	400mmR
GRX	648mm/25.5"	42mm	56mm	20mm	22mm	350mmR
GSA	648mm/25.5"	43mm	57mm	19.5mm	21.5mm	400mmR
JEM	648mm/25.5"	43mm	58mm	18mm	20mm	430mmR
JS	648mm/25.5"	42mm	58mm	20mm	22.3mm	250mmR
JS100	648mm/25.5"	42mm	57mm	20mm	22mm	250mmR
JSM	628mm/24.75"	43.5mm	57mm	20.2mm	23.3mm	COMPOUND
NDM	648mm/25.5"	42mm	57mm	20mm	22mm	240mmR
ORM	610mm/24.0"	43mm	57mm	20.5mm	23mm	320mmR
PGM	648mm/25.5"	43mm	58mm	18mm	20mm	430mmR
PM	628mm/24.75"	43mm	57mm	21mm	23mm	305mmR
PM35	628mm/24.75"	43mm	57mm	20mm	22mm (at 9F)	305mmR
SA/SAS	648mm/25.5"	43mm	56mm (at 21F)	20.5mm	23mm	400mmR
SUPER WIZARD HP	648mm/25.5"	43mm	58mm	17mm	19mm	430mmR
ULTRA HP	648mm/25.5"	43mm	58mm	18mm	20mm	430mmR
ULTRA-8	685.8mm/27"	55mm	80mm	20mm	21.5mm	430mmR
UV	648mm/25.5"	48mm	68mm	19mm	21mm	430mmR
WIZARD	648mm/25.5"	43mm	58mm	18mm	20mm	400mmR
WIZARD HP	648mm/25.5"	43mm	58mm	18mm	20mm	430mmR
WIZARD HP (RGD2120Z)	672mm/26.5"	43mm	58mm	18mm	20mm	430mmR
WIZARD III (RGD)	672mm/26.5"	43mm	58mm	19mm	21mm	400mmR
WIZARD II-7	648mm/25.5"	48mm	68mm	19mm	21mm	400mmR
WIZARD II-7 (RGD)	672mm/26.5"	48mm	68mm	19mm	21mm	400mmR
WIZARD II-8	685.8mm/27"	55mm	80mm	20mm	21.5mm	400mmR
WIZARD III	648mm/25.5"	43mm	58mm	19mm	21mm	400mmR
WIZARD III (DTT)	648mm/25.5"	43mm	57mm	19mm	21mm	400mmR
WIZARD III (RGD)	672mm/26.5"	43mm	58mm	19mm	21mm	400mmR
WIZARD-7	648mm/25.5"	48mm	68mm	19mm	21mm	430mmR
WIZARD-7 (RGD2127Z)	672mm/26.5"	48mm	68mm	19mm	21mm	430mmR
BASS NECK DIMENSIONS						
ARTCORE	770mm/30.3"	42mm	63mm	21.5mm	24.5mm	305mmR
ATK4	864mm/34"	42.5mm	63mm	21mm	24mm	305mmR
ATK4 HP	864mm/34"	42.5mm	63mm	21mm	24mm	305mmR
ATLAS-4	864mm/34"	38mm	62mm	19.5mm	21.5mm	305mmR
ATLAS-4 HP	864mm/34"	38mm	60mm	19.5mm	22.5mm	305mmR
ATLAS-5	864mm/34"	45mm	67mm	19.5mm	21.5mm	305mmR
ATLAS-5 HP	864mm/34"	45mm	67mm	19.5mm	23mm	305mmR
ATLAS-6 HP	864mm/34"	54mm	83mm	19.5mm	23mm	500mmR
BTB4	889mm/35"	41mm	64mm	20mm	22mm	305mmR
BTB5	889mm/35"	47mm	76mm	20mm	22mm	400mmR
BTB6	889mm/35"	54mm	88mm	20mm	22mm	400mmR
Grooveline 4	864mm/34"	38mm	60mm	21mm	24mm	305mmR
Grooveline 5	864mm/34"	43mm	74mm	21mm	24mm	305mmR
GATK	864mm/34"	42.5mm	63mm	21mm	24mm	305mmR
GSR4	864mm/34"	41mm	62mm	21mm	22mm	305mmR
GSR5	864mm/34"	45mm	67mm	21mm	22mm	305mmR
GSRM	726.2mm/28.6"	38mm	58.5mm	21mm	22mm	305mmR
GVB	864mm/34"	53mm	72.3mm	19mm	19.5mm	305mmR
GWB1005	864mm/34"	45mm	67mm	19mm	21mm	305mmR
GWB35	864mm/34"	45mm	67mm	19mm	21mm	305mmR
JTKB	864mm/34"	40mm	64mm	20mm	23mm	305mmR
K5	864mm/34"	45mm	67mm	19.5mm	21.5mm	305mmR
MDB4	864mm/34"	38mm	62mm	21mm	23mm	305mmR
PGBT4	864mm/34"	42.5mm	63mm	21mm	24mm	305mmR
PIB5	864mm/34"	45mm	67mm	21.5mm	23.5mm	305mmR
SDB4	864mm/34"	43mm	60mm	22.5mm	22.5mm	305mmR
SR4	864mm/34"	38mm	62mm	19.5mm	21.5mm	305mmR
SR5	864mm/34"	45mm	67mm	19.5mm	21.5mm	305mmR
SR6	864mm/34"	54mm	83mm	19.5mm	21.5mm	400mmR
SRX4	864mm/34"	38mm	62mm	21mm	23mm	305mmR

PICKUP SPECIFICATIONS

BASS ELECTRONICS

MODEL NO.	NAME	RECOMM. POSITION	CONSTRUCTION	MAGNET	DESCRIPTION KEY
					RECOMMENDED POSITION
					B : BRIDGE, M : MIDDLE, N : NECK
					CONSTRUCTION
					H : HUMBUCKING, S : SINGLE COIL
					BASS ONLY/A : ACTIVE, P : PASSIVE
					MAGNET
					AL : ALNICO, C : CERAMIC

IBANEZ GUITAR PICKUPS					
ACH-BL	ACH-BL	B	H	C	Single coil sized blade humbucking pickup. Sound in-between humbucking and single coil.
ACH1	ARTCORE 1	N	H	C	Clean sounding with a slight overdrive
ACH2	ARTCORE 2	B	H	C	Bridge version of ACH1.
ACH3	ACH3	N	H	C	Well-balanced classic humbucker tone.
ACH4	ACH4	B	H	C	Well-balanced classic humbucker tone.
ACH1-M	ARTCORE 1 Mini	N	H	C	Warm, bright and dry sound.
ACH2-M	ARTCORE 2 Mini	B	H	C	Warm, bright and dry sound.
ACH3-M	ARTCORE 3 Mini	N	H	C	Warm, versatile and crunchy sound.
ACH4-M	ARTCORE 4 Mini	B	H	C	Warm, versatile and crunchy sound.
ACH1-S	ACH1-S	N	H	C	Tight tone with added treble.
ACH2-S	ACH2-S	B	H	C	Bridge version of ACH1-S.
AH1	AXIS HUMBUCKER 1	N	H	C	Very responsive and full sounding; medium output with lots of character. Excellent for chording.
AH2	AXIS HUMBUCKER 2	B	H	AL	Full bass sound. Alnico-5 magnet provide excellent clarity in harmonics and individual notes.
AH5	AXIS HUMBUCKER 5	N	H	C	Very responsive and full sounding; medium output with lots of character. Excellent for chording.
AH6	AXIS HUMBUCKER 6	B	H	AL	Full bass sound. Alnico-5 magnet provides excellent clarity in harmonics and individual notes.
AH1-7	AXIS HUMBUCKER 1-7	N	H	C	Seven-string version of AH1 pickup.
AH2-7	AXIS HUMBUCKER 2-7	B	H	C	Seven-string version of AH2 pickup.
AHS1	AXIS SINGLE 1	N	S	AL	Traditional sounding single coil pickup with increased output for neck position.
AHS2	AXIS SINGLE 2	M	S	AL	Traditional sounding single coil pickup with increased output for center position.
CAP-LZ10	CAP-LoZ	N	H	AL	Active Pickup. High-output yet low noise, with rich tone in mid range.
CAP-LZ20	CAP-LoZ	B	H	C	Active Pickup. High-output yet low noise. The tone was designed with detailed intensity, incredible amounts of middle range with rich tone and fluid sustain.
CAP-VK1	CAP-VK1	N	H	C	Neck version of CAP-VK2.
CAP-VK2	CAP-VK2	B	H	C	High output, specially designed for down-tuning. Having a clarity both in clean sound and in distortion, for extended low end as well as treble response for solo playing.
CAP-VK17	CAP-VK17	N	H	C	Neck version of CAP-VK27.
CAP-VK27	CAP-VK27	B	H	C	CAP-VK2 adjusted for 7strings.
CAP-VM1	CAP-VM1	N	H	AL	Minimum sound loss by adopting OFC coil. Clean and warm, but never restrained. Also offers rich harmonics without distorted.
CAP-VM1S	CAP-VM1S	M	S	AL	Minimum sound loss by adopting OFC coil. Bright and clear single coil tone, yet not thin.
CAP-VM2	CAP-VM2	B	H	AL	Minimum sound loss by adopting OFC coil. High output, offers dynamic range for great response maximizing the nuance of picking.
CAP-CCR1	CAP-CCR1	N	H	AL	Moderate output. Alnico 8 magnet contributes crispy edge with bright high.
CAP-CCR2	CAP-CCR2	B	H	AL	Moderate output. Alnico 8 magnet contributes crispy edge with bright high.
CAP-PP1-N	CAP-PP1-N	N	H	AL	Tube construction of the pole-piece provides quick response, clarity and added harmonics.
CAP-PP1-B	CAP-PP1-B	B	H	C	Tube construction of the pole-piece provides quick response, clarity and added harmonics.
GB SPECIAL	GB SPECIAL	B	H	AL	Floating pickup redesigned by George Benson for hollow bodies at higher volumes. Warm, well rounded output with less feedback.
GB SPECIAL	GB SPECIAL	N	H	AL	Neck version of above.
HGD1	Hot Grinder 1	N	H	AL	Hot, but sharp enough to hear pick bites the strings.
HGD2	Hot Grinder 2	B	H	AL	Hot, but sharp enough to hear pick bites the strings.
INF1	INFINITY 1	N	H	C	Versatile and responsive with warm classic tone and added output.
INF2	INFINITY 2	B	H	AL	Enhanced midrange output. Alnico-5 magnet for individual string clarity. Excellent dynamics.
INF3	INFINITY 3	N	H	C	Provides the dynamic sound for chording and rhythm.
INF4	INFINITY 4	B	H	C	Brilliant lead pickup. Warm sounding with good harmonics.
INFS1	INFINITY SINGLE 1	M	S	AL	Warm single coil tone with added output.
INFS3	INFINITY SINGLE 3	M	S	C	Traditional sounding yet high output. Designed to work with humbuckers in the split position.

LZ1-N	LoZ-N	N	H	C	Traditional sounding yet high output. Designed to work with humbuckers in the split position.
LZ1-B	LoZ-B	B	H	C	High output yet low noise, active pickup operated by AA Batteries (3 volts)
LZ7-N	LoZ-N	N	H	C	Seven-string version of LZ3 pickup.
LZ7-B	LoZ-B	B	H	C	Seven-string version of LZ3 pickup.
LZ8-N	LoZ-N	N	H	C	Eight-string version of LZ3 pickup.
LZ8-B	LoZ-B	B	H	C	Eight-string version of LZ3 pickup.
PSNDS	PSNDS	M/N	S	AL	High output with complete clarity.
PSND1	PSND1	N	H	C	High output in the neck position with no "muddiness."
PSND2	PSND2	B	H	C	High output with enhanced harmonics.
PSND3	PSND3	N	H	AL	High output with plenty of clarity.
PSND4	PSND4	B	H	C	High output works for both lead and rhythm.
S1	SINGLE 1	M/N	S	AL	Traditional sounding, but high output single coil with Alnico-5 polepieces for even string output. Designed to work with humbuckers in the split position.
S58	SUPER 58	all	H	AL	Classic, warm and versatile. Handles both jazz and rock without feedback.
S58C	SUPER 58 Custom	all	H	AL	Classic, warm and versatile.
SL58	SILENT 58	all	H	AL	Classic, warm and versatile. Handles both jazz and rock without feedback.
ST2	Short Tracer	M	S	AL	Alnico magnet provides full output in low profile setting.
STDH1	Standard1	N	H	C	Clear sound with smooth midrange.
STDH2	Standard2	B	H	C	Bridge version of STDH1.
TDB1	True-Duo Bucker	B/N	H	C/AL	Designed for switching between genuine double and single-coil sound in one pickup.
TDB2	True-Duo Blast 1	N	H	C/AL	Same True-Duo constructions as True-Duo Bucker, but the wiring enables True-Duo function as a pair, Bridge and Neck.
TDB3	True-Duo Blast 2	B	H	C/AL	Same True-Duo constructions as True-Duo Bucker, but the wiring enables True-Duo function as a pair, Bridge and Neck.
V7	V7	N	H	C	Tight, but bright. Very dynamic for chording and rhythm.
V7C	V7 Custom	N	H	AL	Smooth and dynamic tone with warm mid-range.
V8	V8	B	H	AL	Warm yet articulate lead pickup with enhanced overtones. Good harmonics without excessive brightness.
V8C	V8 Custom	B	H	C	Rich, harmonic tone with clarity in low-end.
V77	V77	N	H	C	Seven-string version of V7 pickup.
V77C	V77 Custom	N	H	C	Seven-string version of V7C.
V87	V87	B	H	C	Seven-string version of V8 pickup.
V87C	V87 Custom	B	H	C	Seven-string version of V8C.

IBANEZ BASS PICKUPS					
ACHB-2	ACHB-2	B/N	H/P	C	High output humbucking pickup.
ADX5	ACTIVE DYNAMIX 5	B/N	H/A	C	Quiet, dynamic, punchy sound on all 5 strings. Two different sized bobbins provide even string output. Individually calibrated for neck and bridge positions.
CAP-DH	CAP Double Humbucker	B	H/P	C	3 varieties of different tones by combination of two humbuckers in one box; bright, attacking lows/ dynamic and strong low gear for pick use/ smooth and gentle.
CAP-SA4	CAP Sonic Arch 4	B/N	H/P	C	Single-sized humbucker with blade polepiece. Well balanced traditional tone for any music and any style.
CAP-SA5	CAP Sonic Arch 5	B/N	H/P	C	Single-sized humbucker with blade polepiece for 5strings. Well balanced traditional tone for any music and any style.
DXH-5	DYNAMIX-5	B/N	H/P	C	Powerful with good midrange punch.
EXF-4	EX FULL RANGE 4	B/N	H/P	C	Balanced tone and sound among each string.
EXF-5	EX FULL RANGE 5	B/N	H/P	C	5-string version of EXF-4.
PFR-4	PASSIVE FULL RANGE	B/N	H/P	C	Powerful full range pickup with added low mids.
PFR-5	PASSIVE FULL RANGE	B/N	H/P	C	Powerful full range pickup with added low mids.
PFR-AL4	PASSIVE FULL RANGE	B/N	H/P	AL	Powerful Alnico magnet pickup with exceptional clarity and very even response.
PFR-AL5	PASSIVE FULL RANGE	B/N	H/P	AL	5-string version of PFR-AL4.
PSJ	POWER SINGE J	B/N	S/P	C	Powerful single sound with sharpness.
PPD4	POWERPOLE DUAL COIL	B/N	H/P	C	Passive bass sound with plenty of punch.
PSNDJ	PSNDJ	B/N	H/P	C	High output with added highs.
PSNDP	PSNDP	B/N	H/P	C	High output with plenty of punch.
SFR-GWB	SONIC FULL RANGE	B/N	H/P	C	Custom wound for GWB35. Quick attack, superior dynamics and added highs.
STD-P2	STANDARD P2	B/N	H/P	C	Powerful sound with plenty of punch.
STD-J2	STANDARD J2	B/N	S/P	C	Powerful sound with added highs.
STD-M	STANDARD M	B	H/P	C	Powerful humbucker sound with dynamics.

