

AMX/A-11 Ghibli Italia "30th anniversary special"

Designed for 1/72 scale: recommended kit Italeri AMX kit #1460 or #1471 for AMX-T trainer

HISTORY

The AMX was developed as a project of AerMACchi of Italia for a ground attack aircraft starting early 1970s. In 1980 Brasil joined the program with EMBRAER. AMX International, an Italian-Brazilian joint venture, was formed to develop, manufacture, and market the aircraft. It is called A-11 Ghibli by the Italian Air Force and A-1 by the Brazilian Air Force. (The EMBRAER version is different with other systems, another DEFA gun and later additional ECM).

Decals are on this sheet for 3 different Italian Air Force (AM) "Aeronautica Militare" AMX jets with special tails as the 30th anniversary was celebrated in 2019.

DECALS SYSTEM

The decal sheet has one continuous print film, so each decal needs to be cut out with fine scissors.

No other prior decal preparation is needed.

Each cut out decal can be applied as usual after soaking it a short while in water. Decals are VERY THIN, so slide off from the wet backing sheet on a horizontally held GLOSSY model surface.

Note that a decal that contains a white section is often split in two parts. To get the full decal marking, apply both. On the decals sheet you will often see an "arrow" to indicate this way of application (on white under surfaces, the white section is optional). (SEE NOTE*)

After all decals have been applied, finish the model with your preferred final gloss, matt or semi-matt varnish coats. This will also protect all the decals.

CAMOUFLAGE AND SCHEMES

The standard Italian Air Force AMX scheme is an overall base grey (FS 36280).

Undercarriage bays are usually very light grey FS36495 with "off white" gear struts. Cockpit interior mostly light grey FS36495, black ejection seat with dark green pack.

NOTE*: how to apply the different left and right special tails, see steps in each scheme drawing. The upper fuselage colours in front of the tail blend in.

The stencilling, maintenance markings and items like the low-visibility strips are to be used from the model kit.

Black areas are also common on nose and spine. It is strongly recommended to study photos in books and internet to seek a good colour match:

<https://www.airliners.net/> and [theaviationist](http://theaviationist.com) < link

Search with "AMX + MM code"

MODEL KITS

In 1/72 scale Italeri issued a good injection moulded kit #1460 for modelling the Ghibli. For the twin seater AMX-T trainer use kit #1471.

See the AMX modelling report of these kits at: <https://aircraftinplastic.com/models/amx/amx-1.html>

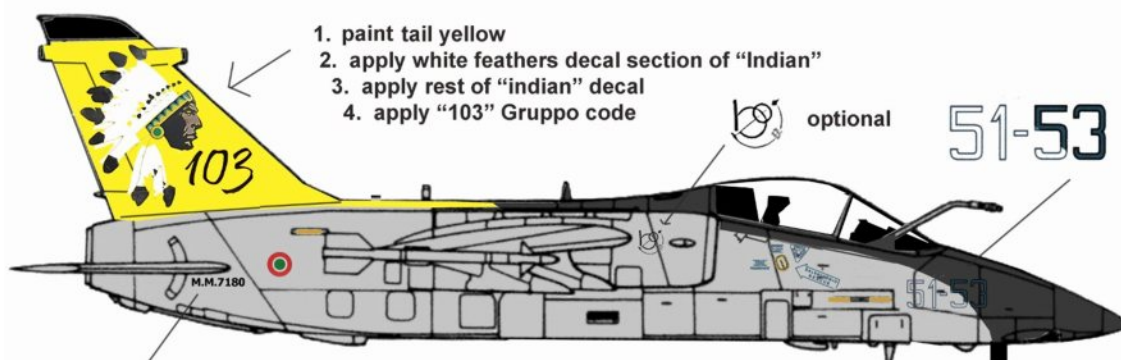
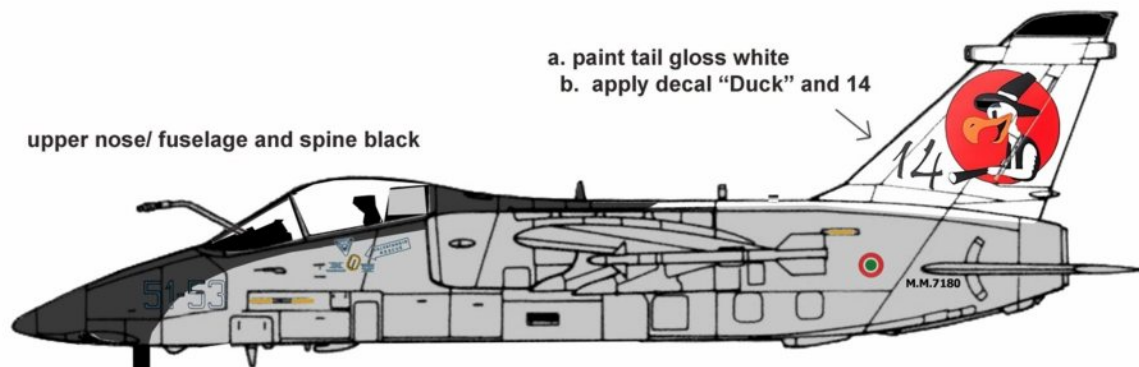

AMX MM7180 , code 51-53 (103 Gruppo "Indian" right / 14 Gruppo "Duck" left)

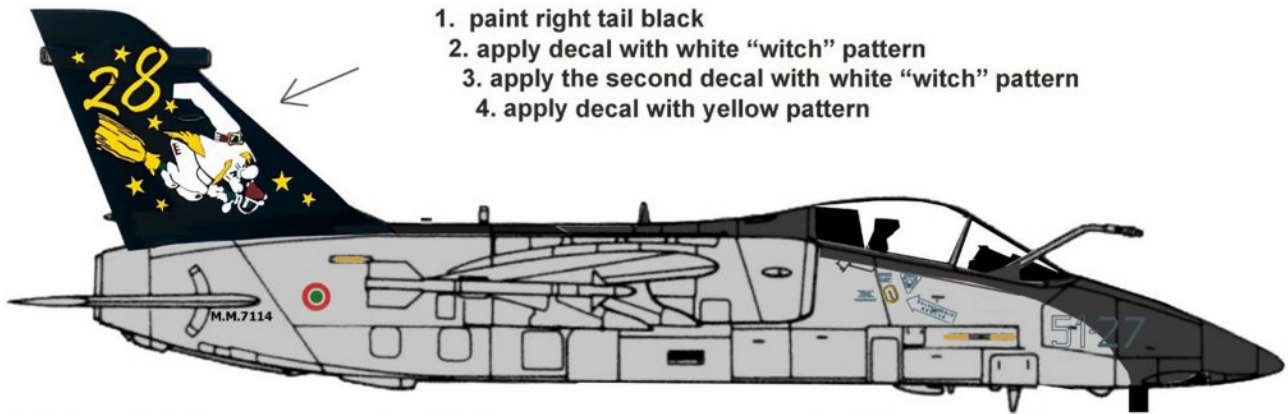
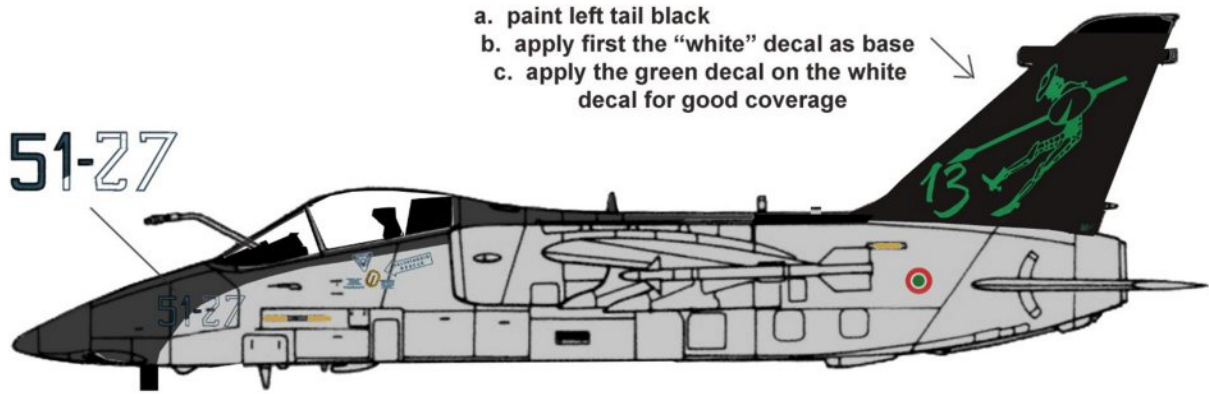

AMX MM7114 , code 51-27 (28 Gruppo "witch" right / 13 Gruppo left)

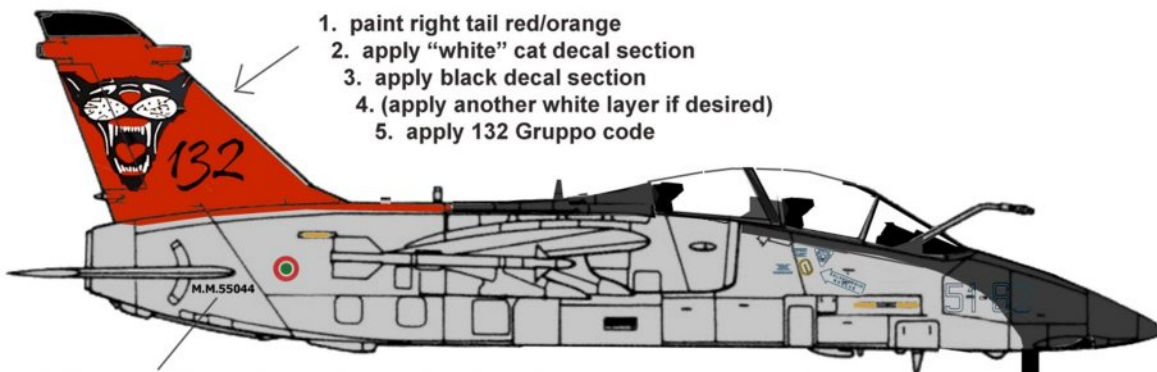
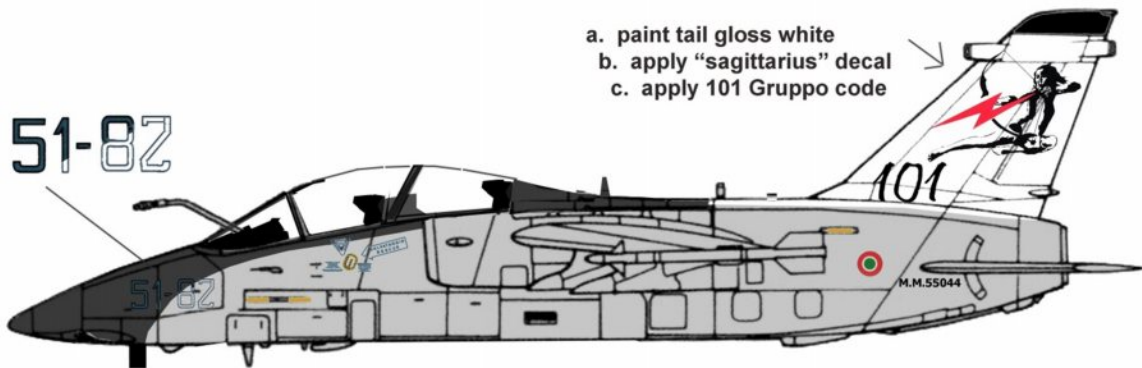

AMX -T MM55044 , code 51-82 (132 Gruppo right / 101 Gruppo left)

Use the Italeri kit instructions for details such as stencilling and Italia roundels. Note the black tail tip and nose areas.

Please visit website: www.aircraftinplastic.com