

**YAMAHA**

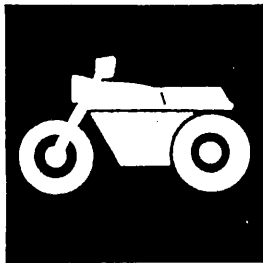

**PARTS  
CATALOGUE**

**XT600E'98 (4PT7) EUROPE**

**XT600E'98 (4SL4) SWITZERLAND**

---

**YAMAHA**  
**GENUINE**  
Parts & Accessories

184-PT-300E1

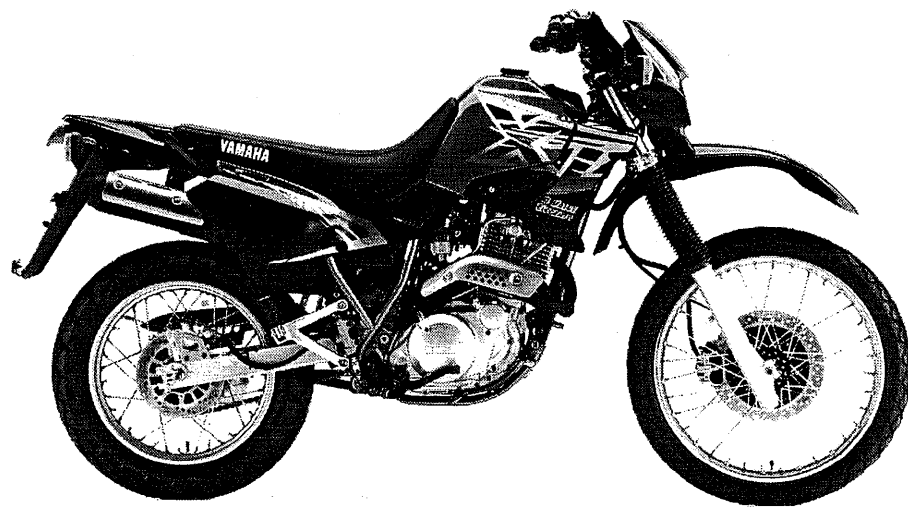

A3

# FOREWORD

This Parts Catalogue is related to the parts for the model(s) in the below frame. When you are ordering replacement parts, please refer to this Parts Catalogue and quote both part numbers and part names correctly.

XT600E'98(4PT7/4SL4)

1. Modifications or additions which have been made after issue of the Parts Catalogue will be announced in the Yamaha Parts News.  
It is advisable that you make necessary corrections to the Parts Catalogue according to the Yamaha Parts News.

**2. Abbreviations**

The Following abbreviations are used in this Parts Catalogue.

"UR" Use specified parts number.

"UN" Use as many as needed.

"AP" Alternate Parts

"UM" Local Made (Parts need to be ordered locally)

"F#" Frame No. (Applicable machine No.)

3. Parts, which are to be supplied in an assembly, are listed with a dot(.) in front of the part name as shown below.

**EXAMPLE**

CARBURETOR ASSY

.JET, PILOT

.NOZZLE, MAIN

4. Number of component for assembly

The numeral appearing to the right of each component part indicates the quantity of parts for each assembly unit.

**EXAMPLE**

PART NO.	DESCRIPTION	Q'TY	REMARKS
2F5-83310-60	FRONT FLASHER LIGHT ASSY	2	
115-83311-60	.BULB (6V-18W)	1	
1M1-83309-60	.REFLECTOR	1	

5. Applicable colors of graphics are represented in the "REMARKS" as shown below.

PART NO.	DESCRIPTION	Q'TY	REMARKS
2N4-24110-00-X5	.FUEL TANK COMP.	2	MXR
3J1-24240-10	.GRAPHIC, FUEL TANK	1	for MXR

6. Applicable Serial No.

① Engine Serial No.

② Frame Serial No.

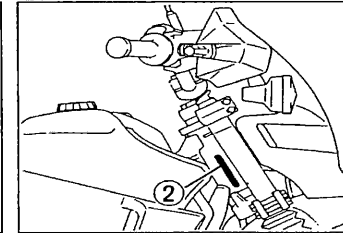
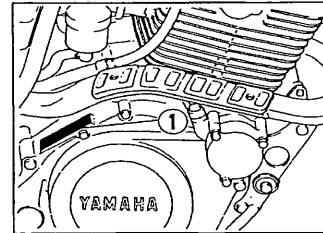

7. Note that the illustrations for reference in finding parts numbers, not to be used for assembling. When assembling, please use the applicable service manual.

8. The asterisk (\*) before a reference number indicates modification items after the first edition.

# MODEL LABEL

(1) A label called "Model Label" is affixed in the location as indicated in (3) below.  
When using this parts catalogue, please be sure to cross-refer the "model code - production code No." in the catalogue to the "model code - production code No." indicated on the Model Label affixed onto the product concerned.

(2) "Model Label" Indication

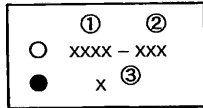

① Model Type Code  
② Production Code No.  
③ Colouring Type

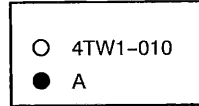

(3) Model Label Affixing Location

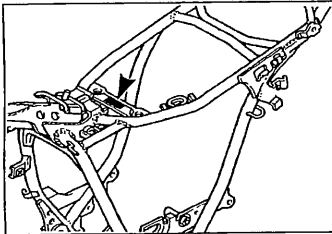

(4) Model Code - Production Code Number of Model Listed in This Parts Catalog

Model Code	Production Code No.	Country (destination)	Model Code	Production Code No.	Country (destination)
4PT7	020	BELGIUM			
	040	DENMARK			
	050	ENGLAND			
	060	GREECE			
	070	ITALY			
	080	HOLLAND			
	090	NORWAY			
	100	PORTUGAL			
	110	SWEDEN			
4SL4	010	SWITZERLAND			

(5) Colouring Information

Colouring type code	Colour code	Colour Name	Abbreviation
A	0206	PURPLISH WHITE SOLID 1	PWS1
B	0033	YAMAHA BLACK	YB

# CONTENTS

## ENGINE

CYLINDER HEAD -----	B2
CYLINDER -----	B4
CRANKSHAFT. PISTON-----	B5
VALVE -----	B7
CAMSHAFT. CHAIN -----	B8
OIL PUMP -----	B9
INTAKE -----	B11
INTAKE 2-----	B14
CARBURETOR-----	C2
CARBURETOR 2-----	C4
EXHAUST -----	C6
CRANKCASE -----	C7
CRANKCASE COVER 1-----	C8
STARTER CLUTCH-----	C10
CLUTCH -----	C11
TRANSMISSION -----	C13
SHIFT CAM. FORK -----	C15
SHIFT SHAFT-----	D2

## CHASSIS

FRAME -----	D3
FENDER -----	D5
SIDE COVER -----	D7
REAR ARM -----	D8
REAR SUSPENSION -----	D10
STEERING -----	D11
FRONT FORK-----	D12
FUEL TANK-----	D14
SEAT -----	E2
FRONT WHEEL -----	E3
REAR WHEEL -----	E5
REAR BRAKE CALIPER-----	E7

STEERING HANDLE. CABLE -----	E8
FRONT MASTER CYLINDER -----	E9
STAND. FOOTREST -----	E10
REAR MASTER CYLINDER-----	E11
COWLING 1 -----	E13
GENERATOR -----	E14
FLASHER LIGHT -----	E15
METER -----	F2
HEADLIGHT -----	F3
TAILLIGHT -----	F4
HANDLE SWITCH. LEVER -----	F5
ELECTRICAL 1 -----	F6
ELECTRICAL 2 -----	F7

## INDEX

NUMERICAL INDEX -----	M1
-----------------------	----

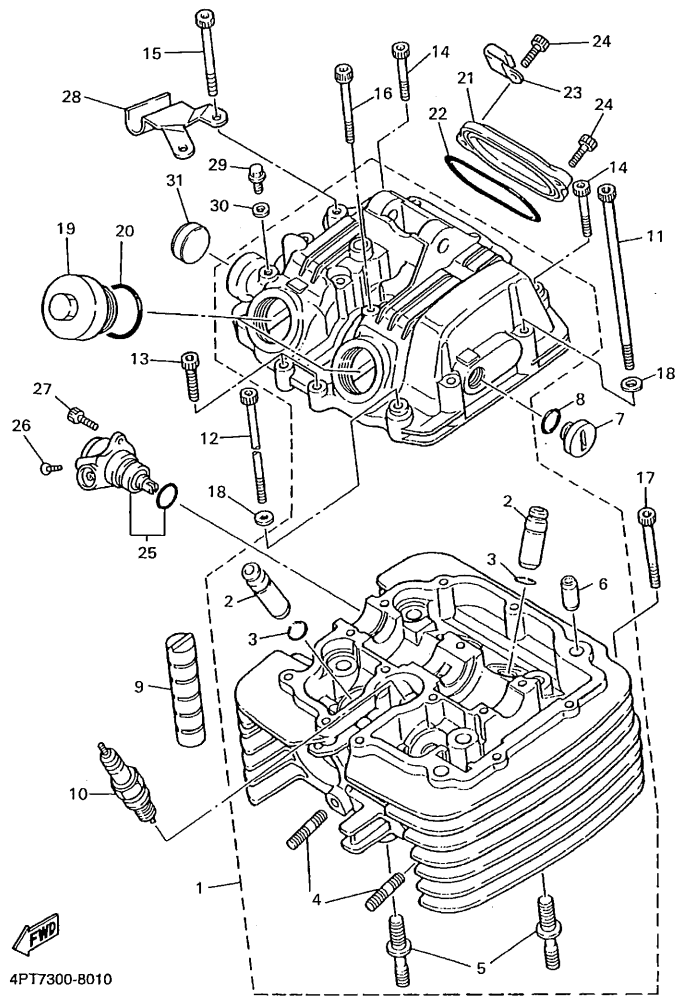
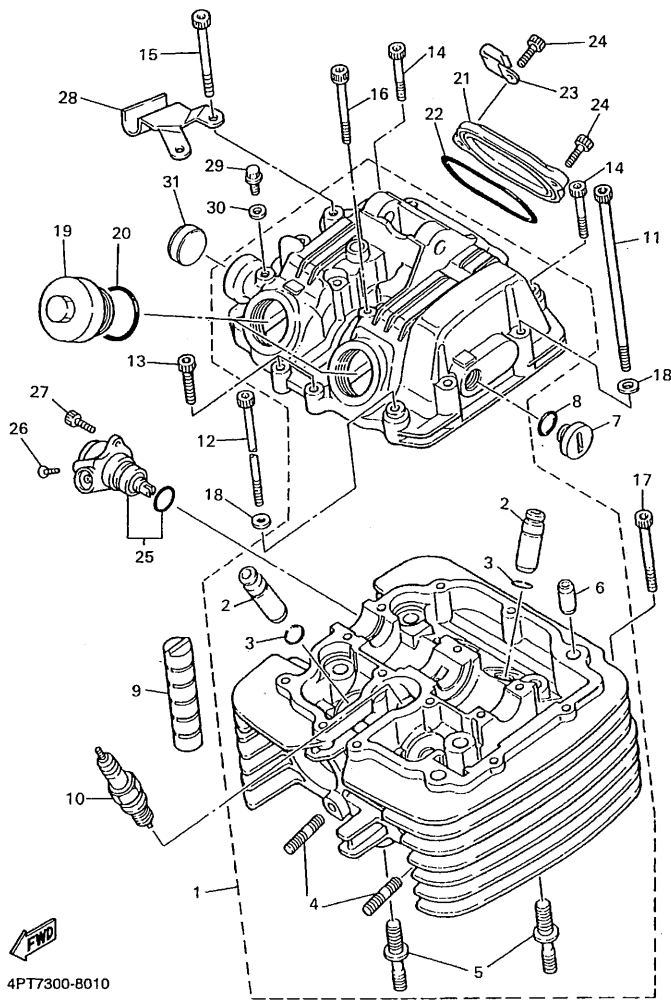

FIG. 1 CYLINDER HEAD

REF. NO.	PART NO.	DESCRIPTION	4PT7	4SL4	REMARKS
1	3TB-11101-02	CYLINDER HEAD ASSY	1	1	
2	4H7-11133-10	.GUIDE, INTAKE VALVE	4	4	
3	93440-12052	.CIRCLIP	4	4	
4	90116-06475	.BOLT, STUD	4	4	
5	90116-10378	.BOLT, STUD	2	2	
6	99530-10116	.PIN, DOWEL	2	2	
7	90340-14068	PLUG, STRAIGHT SCREW	1	1	
8	93210-13657	O-RING	1	1	
9	583-11127-00	ABSORBER 3	2	2	
10	94701-00241	PLUG, SPARK (NGK DPR8EA-9)	1	1	
11	91317-06125	BOLT	2	2	
12	91317-06115	BOLT	1	1	
13	91317-06025	BOLT	4	4	
14	91317-06040	BOLT	2	2	
15	91317-06055	BOLT	6	6	
16	90109-063E9	BOLT	1	1	
17	91317-06050	BOLT	1	1	
18	92907-06600	WASHER, PLATE	3	3	
19	1L9-11186-00	COVER, CYLINDER HEAD SIDE 2	2	2	
20	93210-32172	O-RING	2	2	
21	5Y1-11187-00	COVER, CYLINDER HEAD SIDE 3	1	1	
22	93210-62523	O-RING	1	1	
23	90465-08125	CLAMP		1	
24	91317-06018	BOLT	2	2	
25	1JK-17800-01	GEAR UNIT ASSY, TACHO. DRIVE	1	1	
26	98707-06030	SCREW, FLAT HEAD	1	1	
27	91317-06025	BOLT	1	1	

FIG. 1 CYLINDER HEAD



4PT7300-8010

REF. NO.	PART NO.	DESCRIPTION	4PT7	4SL4	REMARKS
28	90462-20217	CLAMP	1	1	
29	90109-06418	BOLT	1	1	
30	90430-06014	GASKET	1	1	
31	90338-22207	PLUG	1	1	

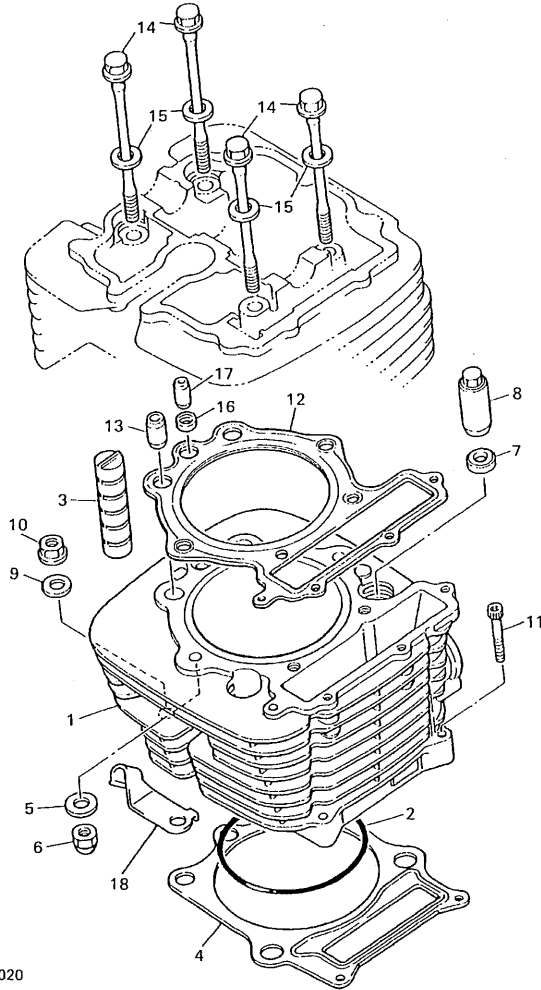

4PT351-6020

FIG. 2 CYLINDER

REF. NO.	PART NO.	DESCRIPTION	4PT7	4SL4	REMARKS
1	3TB-11310-00	CYLINDER	1	1	
2	93210-98473	O-RING	1	1	
3	583-11127-00	ABSORBER 3	2	2	
4	1VJ-11351-00	GASKET, CYLINDER	1	1	
5	90201-080L8	WASHER, PLATE	2	2	
6	90176-08026	NUT, CROWN	2	2	
7	90201-10590	WASHER, PLATE	2	2	
8	90179-10201	NUT	2	2	
9	90201-10124	WASHER, PLATE	1	1	
10	90179-10279	NUT	2	2	
11	91317-06035	BOLT	2	2	
12	2KF-11181-01	GASKET, CYLINDER HEAD 1	1	1	
13	99530-12016	PIN, DOWEL	2	2	
14	90105-08505	BOLT, WASHER BASED	4	4	
15	90201-085L3	WASHER, PLATE	4	4	
16	90430-08178	GASKET	1	1	
17	99530-08016	PIN, DOWEL	1	1	
18	4PT-1131E-00	HOLDER 1	1	1	



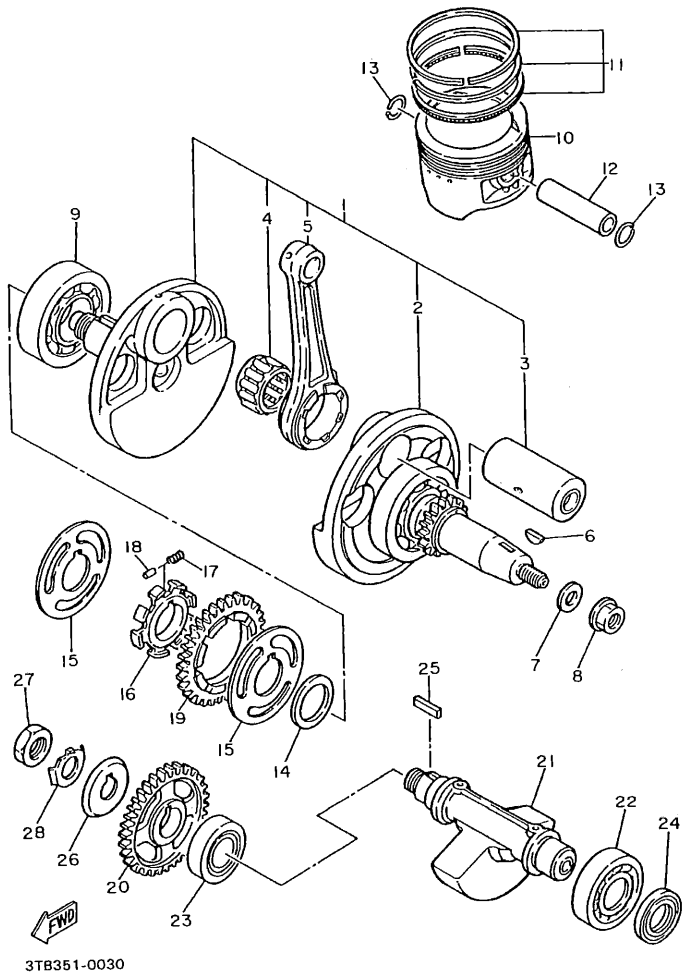

3TB351-0030

FIG. 3 CRANKSHAFT. PISTON

REF. NO.	PART NO.	DESCRIPTION	4PT7	4SL4	REMARKS
1	3TB-11400-00	CRANKSHAFT ASSY	1	1	
2	1VJ-W1141-00	.CRANK 1	1	1	
3	1VJ-11681-00	.PIN, CRANK 1	1	1	
4	93310-635D4	.BEARING	1	1	
5	3TB-11651-00	.ROD, CONNECTING	1	1	
6	90280-16053	KEY, WOODRUFF	1	1	
7	90201-14226	WASHER, PLATE	1	1	
8	90179-14317	NUT	1	1	
9	93306-30702	BEARING (B6307)	1	1	
10	3TB-11631-00-Y0	PISTON (STD)	1	1	
	3TB-11636-00	PISTON (0.50MM O/S)	1	1	AP
	3TB-11638-00	PISTON (1.00MM O/S)	1	1	AP
11	34L-11610-00	PISTON RING SET (STD)	1	1	
	34L-11610-20	PISTON RING SET (0.50MM O/S)	1	1	AP
	34L-11610-40	PISTON RING SET (1.00MM O/S)	1	1	AP
12	1JK-11633-01	PIN, PISTON	1	1	
13	93450-24028	CIRCLIP	2	2	
14	90201-301F4	WASHER, PLATE	1	1	
15	34K-11565-02	WASHER, BEARING COVER	2	2	
16	5Y1-11496-01	BOSS, BUFFER	1	1	
17	90501-22721	SPRING, COMPRESSION	8	8	
18	93605-10090	PIN, DOWEL	4	4	
19	2JT-11536-00	GEAR, DRIVE	1	1	
20	5Y1-11531-00	GEAR, BLANCE WT 44T	1	1	
21	34K-11454-00	WEIGHT 1	1	1	
22	93306-30525	BEARING (B6305)	1	1	
23	93306-30534	BEARING	1	1	



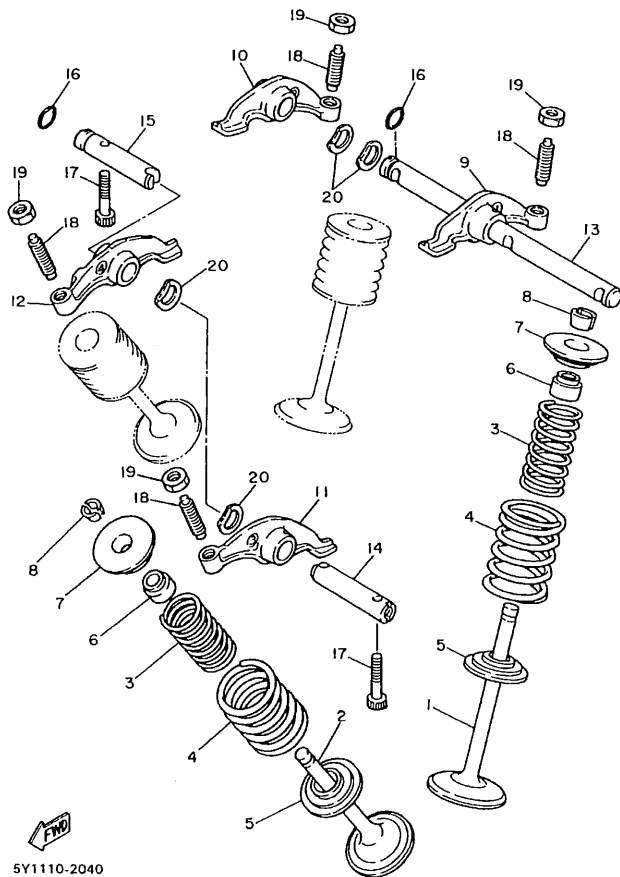

5Y1110-2040

FIG. 4 VALVE

REF. NO.	PART NO.	DESCRIPTION	4PT7	4SL4	REMARKS
1	1VJ-12111-00	VALVE, INTAKE	2	2	
2	1VJ-12121-00	VALVE, EXHAUST	2	2	
3	5Y1-12113-00	SPRING, VALVE INNER	4	4	
4	5Y1-12114-00	SPRING, VALVE OUTER	4	4	
5	4H7-12116-00	SEAT, VALVE SPRING	4	4	
6	1J7-12119-01	SEAL, VALVE STEM	4	4	
7	2F3-12117-00	RETAINER, VALVE SPRING	4	4	
8	1J7-12118-00	COTTER, VALVE	8	8	
9	34K-12151-00	ARM, VALVE ROCKER	1	1	
10	34K-12161-00	ARM, VALVE ROCKER 2	1	1	
11	34K-12162-00	ARM, VALVE ROCKER 3	1	1	
12	34K-12163-00	ARM, VALVE ROCKER 4	1	1	
13	2NX-12146-00	SHAFT, ROCKER	1	1	
14	2NX-12156-00	SHAFT, ROCKER 2	1	1	
15	2NX-12166-00	SHAFT, ROCKER 3	1	1	
16	93210-08521	O-RING	2	2	
17	90109-063E8	BOLT	2	2	
18	2NX-12159-00	SCREW, VALVE ADJUSTING	4	4	
19	90170-06128	NUT	4	4	
20	90206-12075	WASHER, WAVE	4	4	

FIG. 5 CAMSHAFT CHAIN

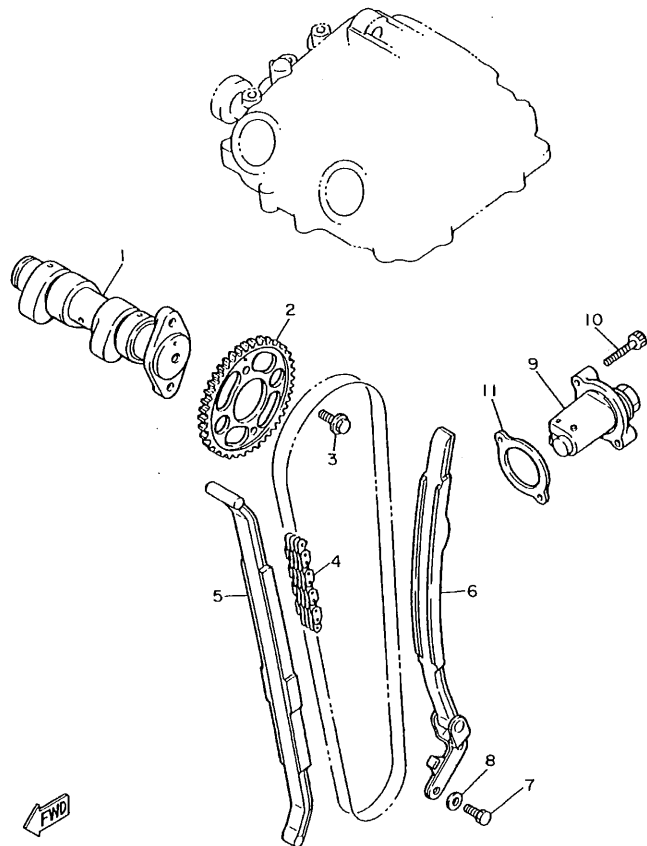

REF. NO.	PART NO.	DESCRIPTION	4PT7	4SL4	REMARKS
1	1JK-12170-00	CAMSHAFT ASSY 1	1	1	
2	3TB-12176-00	SPROCKET, CAM CHAIN	1	1	
3	90105-07342	BOLT, WASHER BASED	2	2	
4	94590-27126	CHAIN	1	1	
5	34K-12231-00	GUIDE, STOPPER 1	1	1	
6	34K-12241-00	GUIDE, STOPPER 2	1	1	
7	97027-06016	BOLT	2	2	
8	92907-06600	WASHER, PLATE	2	2	
9	3TB-12210-00	TENSIONER ASSY, CAM CHAIN	1	1	
10	91317-06025	BOLT	2	2	
11	4DW-12213-00	GASKET, TENSIONER CASE	1	1	

3AJ1351-8050

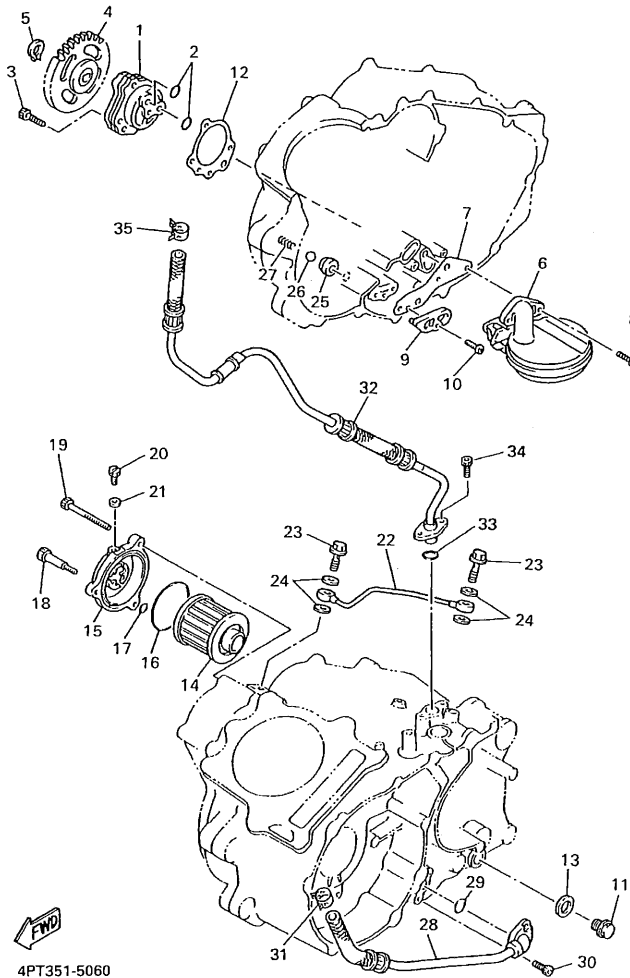

FIG. 6 OIL PUMP

REF. NO.	PART NO.	DESCRIPTION	4PT7	4SL4	REMARKS
1	3AJ-13300-01	OIL PUMP ASSY	1	1	
2	93210-13361	O-RING	2	2	
3	91317-06035	BOLT	3	3	
4	3AJ-13325-00	GEAR, PUMP DRIVEN	1	1	
5	99009-11400	CIRCLIP	1	1	
6	5Y1-W1343-00	STRAINER COMP.	1	1	
7	4DW-13415-00	SEAL, OIL STRAINER	1	1	
8	98507-06016	SCREW, PAN HEAD	2	2	
9	5Y1-15427-01	COVER, CAP 2	1	1	
10	98507-06016	SCREW, PAN HEAD	1	1	
11	90340-14132	PLUG, STRAIGHT SCREW	1	1	
12	3SX-13329-00	GASKET, PUMP COVER	1	1	
13	214-11198-01	GASKET	1	1	
14	4X7-13440-01	ELEMENT ASSY, OIL CLEANER	1	1	
15	4PT-13447-00	COVER, OIL ELEMENT	1	1	
16	93210-64297	O-RING	1	1	
17	93210-07135	O-RING	1	1	
18	90109-06419	BOLT	1	1	
19	91317-06080	BOLT	2	2	
20	90149-05110	SCREW	1	1	
21	90430-05126	GASKET	1	1	
22	3AJ-13161-01	PIPE, DELIVERY 1	1	1	
23	90401-08133	BOLT, UNION	2	2	
24	90430-08204	GASKET	4	4	
25	583-13113-00	SEAT, CHECK BALL	1	1	
26	93503-08007	BALL	1	1	
27	90501-043E0	SPRING, COMPRESSION	1	1	



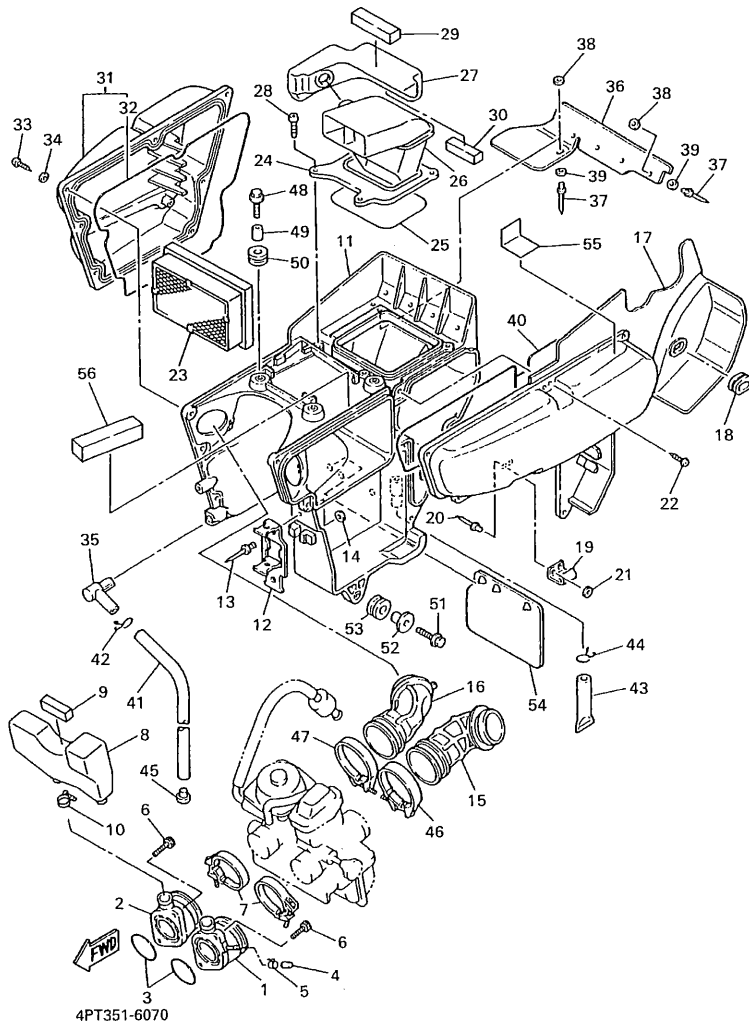

FIG. 7 INTAKE

REF. NO.	PART NO.	DESCRIPTION	4PT7	4SL4	REMARKS
1	4PT-13586-00	JOINT, CARBURETOR 1	1		
2	4PT-13596-00	JOINT, CARBURETOR 2	1		
3	93210-36769	O-RING	2		
4	16G-13569-00	PLUG, BLIND	1		
5	90467-10039	CLIP	1		
6	91317-06020	BOLT	4		
7	90460-46206	CLAMP, HOSE	2		
8	4PT-13581-00	CHAMBER, AIR	1		
9	2XJ-84345-00	DAMPER, HEADLIGHT	1		
10	90450-21082	HOSE CLAMP ASSY	2		
11	3TB-14411-01	CASE, AIR CLEANER 1	1		
12	3TB-81953-00	STAY, RELAY	1		
13	90267-40075	RIVET, BLIND	1		
14	92907-04600	WASHER	1		
15	3TB-14453-00	JOINT, AIR CLEANER 1	1		
16	3TB-14454-00	JOINT	1		
17	3TB-1441A-00	COVER, CLEANER CASE 1	1		
18	90480-12325	GROMMET	1		
19	43G-14436-00	HOOK	1		
20	90267-40075	RIVET, BLIND	2		
21	92907-04600	WASHER	2		
22	97707-50520	SCREW, TAPPING	7		
23	4PT-14451-01	ELEMENT, AIR CLEANER	1		
24	4PT-14412-00	CAP, CLEANER CASE 1	1		
25	3TB-14457-00	SEAL	1		
26	4PT-14437-00	DUCT	1		
27	4PT-14431-00	SILENCER, INTAKE 1	1		

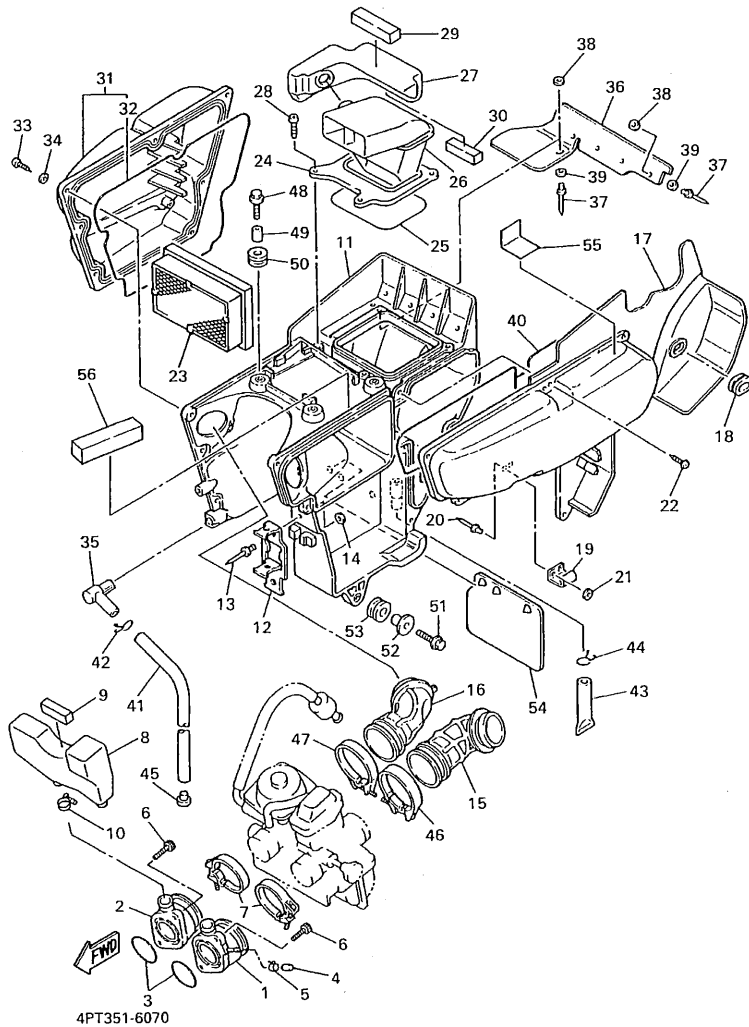

FIG. 7 INTAKE

REF. NO.	PART NO.	DESCRIPTION	4PT7	4SL4	REMARKS
28	97707-50520	SCREW, TAPPING	4		
29	3YF-14462-00	SEAL	1		
30	2XJ-84345-00	DAMPER, HEADLIGHT	1		
31	3TB-1441E-00	COVER, CLEANER CASE 2	1		
32	55K-14476-00	.SEAL	1		
33	98507-05020	SCREW, PAN HEAD	7		
34	92907-05600	WASHER, PLATE	7		
35	5Y1-14419-00	PIPE	1		
36	3TB-21621-00	FLAP	1		
37	90267-40077	RIVET, BLIND	5		
38	90201-047A2	WASHER, PLATE	5		
39	92907-04200	WASHER	5		
40	3TB-14452-00	SEAL	1		
41	90445-122H1	HOSE	1		
42	90467-12052	CLIP	1		
43	34X-1443E-00	PIPE, DRAIN	1		
44	90467-11106	CLIP	1		
45	90338-08174	PLUG	1		
46	90460-51059	CLAMP, HOSE	1		
47	90460-58124	CLAMP, HOSE	1		
48	95807-06020	BOLT, FLANGE	3		
49	90387-06033	COLLAR	3		
50	90480-14329	GROMMET	3		
51	95827-06025	BOLT, FLANGE	1		
52	90387-075H4	COLLAR	1		
53	90480-15064	GROMMET	1		
54	34X-21691-00	FLAP	1		



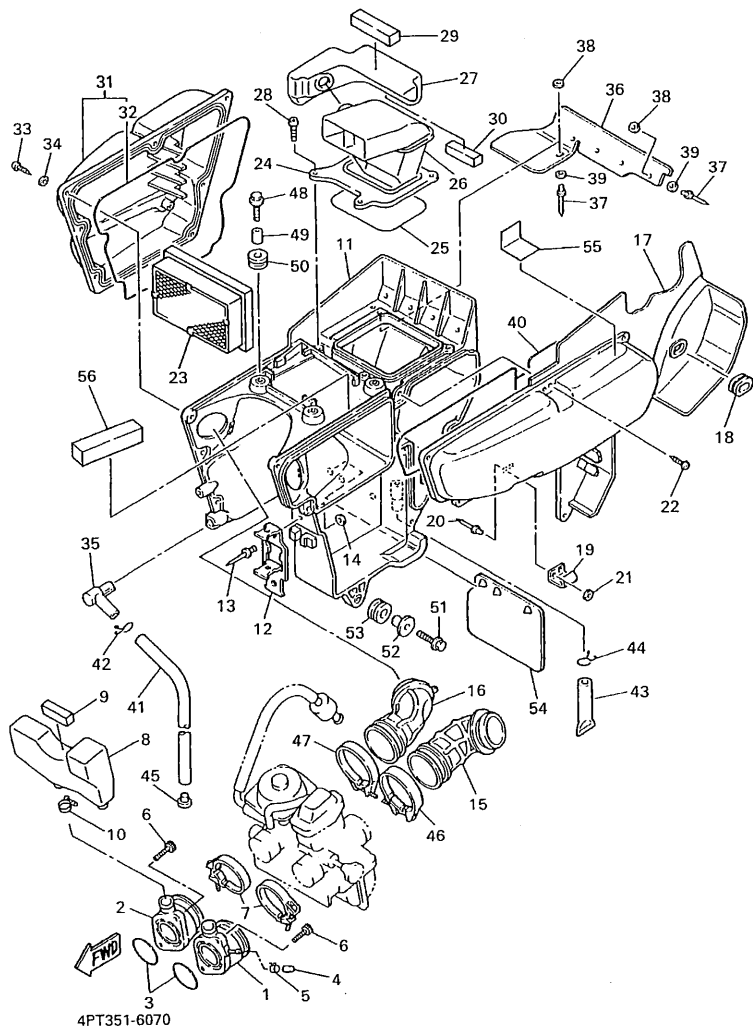
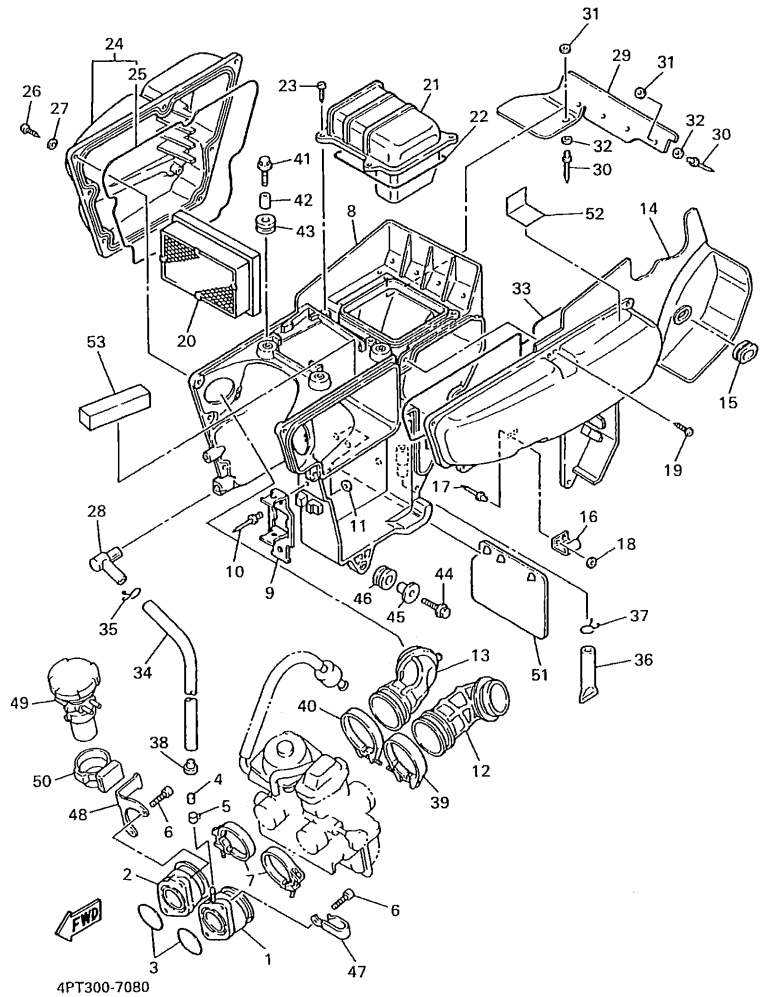

FIG. 7 INTAKE

REF. NO.	PART NO.	DESCRIPTION	4PT7	4SL4	REMARKS
55	4PT-14462-00	SEAL	1		
56	89A-77214-00	TRIM, LOWER	1		



4PT300-7080

FIG. 8 INTAKE 2

REF. NO.	PART NO.	DESCRIPTION	4PT7	4SL4	REMARKS
1	43F-13586-01	JOINT, CARBURETOR 1		1	
2	1VJ-13596-00	JOINT, CARBURETOR 2		1	
3	93210-36769	O-RING		2	
4	16G-13569-00	PLUG, BLIND		1	
5	90467-10039	CLIP		1	
6	91317-06020	BOLT		4	
7	90460-46206	CLAMP, HOSE		2	
8	3TB-14411-01	CASE, AIR CLEANER 1		1	
9	3TB-81953-00	STAY, RELAY		1	
10	90267-40075	RIVET, BLIND		1	
11	92907-04600	WASHER		1	
12	3TB-14453-00	JOINT, AIR CLEANER 1		1	
13	3TB-14454-00	JOINT		1	
14	3TB-1441A-00	COVER, CLEANER CASE 1		1	
15	90480-12325	GROMMET		1	
16	43G-14436-00	HOOK		1	
17	90267-40075	RIVET, BLIND		2	
18	92907-04600	WASHER		2	
19	97707-50520	SCREW, TAPPING		7	
20	4PT-14451-01	ELEMENT, AIR CLEANER		1	
21	3TB-14412-00	CAP, CLEANER CASE 1		1	
22	3TB-14457-00	SEAL		1	
23	97707-50520	SCREW, TAPPING		4	
24	3TB-1441E-00	COVER, CLEANER CASE 2		1	
25	55K-14476-00	.SEAL		1	
26	98507-05020	SCREW, PAN HEAD		7	
27	92907-05600	WASHER, PLATE		7	

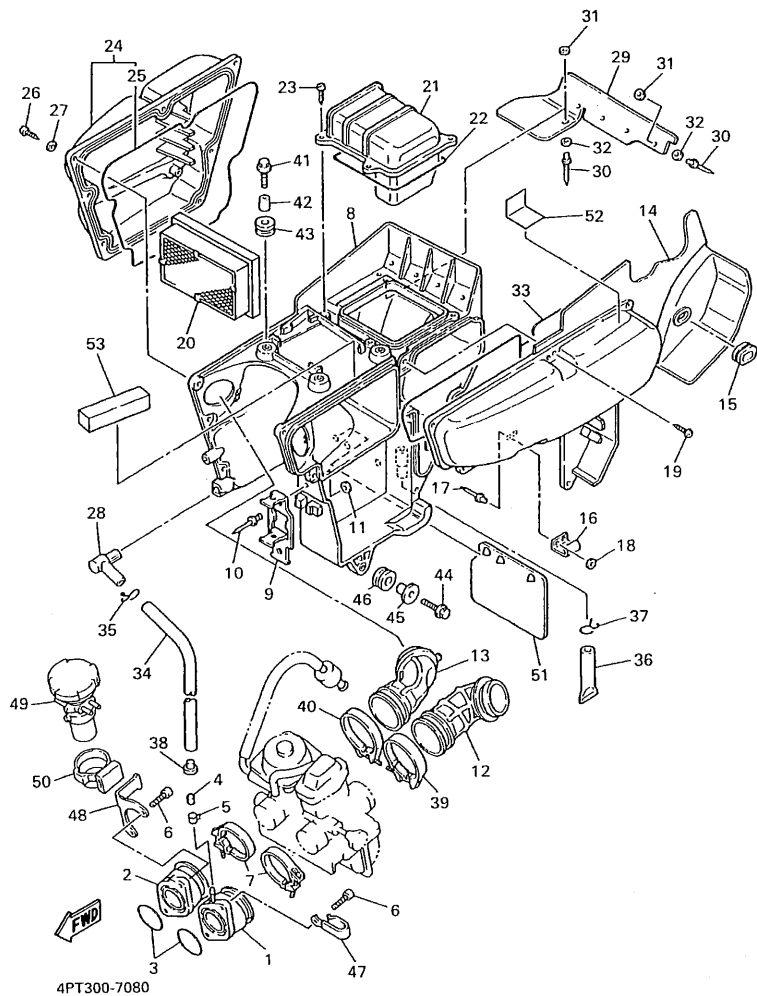
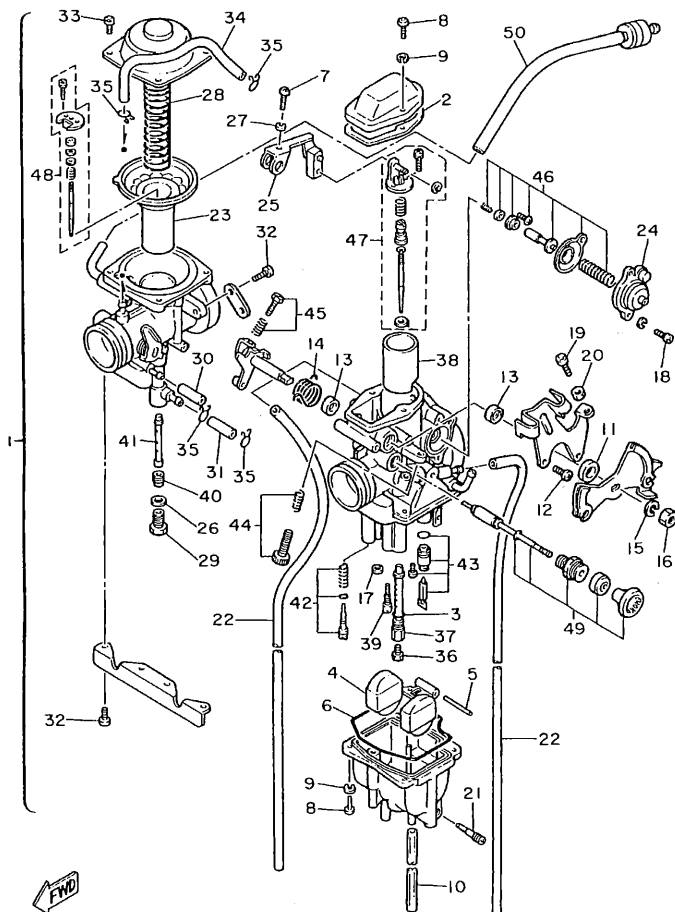

FIG. 8 INTAKE 2

REF. NO.	PART NO.	DESCRIPTION	4PT7	4SL4	REMARKS
28	5Y1-14419-00	PIPE		1	
29	3TB-21621-00	FLAP		1	
30	90267-40077	RIVET, BLIND		5	
31	90201-047A2	WASHER, PLATE		5	
32	92907-04200	WASHER		5	
33	3TB-14452-00	SEAL		1	
34	90445-122H1	HOSE		1	
35	90467-12052	CLIP		1	
36	34X-1443E-00	PIPE, DRAIN		1	
37	90467-11106	CLIP		1	
38	90338-08174	PLUG		1	
39	90460-51059	CLAMP, HOSE		1	
40	90460-58124	CLAMP, HOSE		1	
41	95807-06020	BOLT, FLANGE		3	
42	90387-06033	COLLAR		3	
43	90480-14329	GROMMET		3	
44	95827-06025	BOLT, FLANGE		1	
45	90387-075H4	COLLAR		1	
46	90480-15064	GROMMET		1	
47	90465-08125	CLAMP		1	
48	3UX-1441L-01	PANEL 1		1	
49	3UX-14303-00	COMPENSATOR ASSY		1	
50	2WJ-14445-01	GROMMET		1	
51	34X-21691-00	FLAP		1	
52	4PT-14462-00	SEAL		1	
53	89A-77214-00	TRIM, LOWER		1	



3TB332-0080

FIG. 9 CARBURETOR

REF. NO.	PART NO.	DESCRIPTION	4PT7	4SL4	REMARKS
1	4PT-14301-01	CARBURETOR ASSY 1	1		
2	5Y1-14198-00	.GASKET	1		
3	360-24512-00	.GASKET	2		
4	2JN-14385-00	.FLOAT	1		
5	689-14386-00	.PIN, FLOAT	1		
6	5Y1-14384-00	.GASKET, FLOAT CHAMBER	1		
7	98580-04016	.SCREW, PAN HEAD	1		
8	98501-04014	.SCREW, PAN HEAD	6		
9	92902-04100	.WASHER, SPRING	6		
10	1VJ-14197-00	.PIPE	1		
11	1JK-14357-00	.COLLAR	1		
12	214-24535-00	.SCREW, LEVER FITTING	2		
13	5Y1-14572-00	.PLATE, STAY	2		
14	1XL-14131-00	.SPRING, THROTTLE VALVE	1		
15	5Y1-14356-00	.WASHER, SPRING	1		
16	5Y1-14358-00	.NUT	1		
17	5Y1-14536-00	.GASKET	1		
18	98501-04010	.SCREW, PAN HEAD	2		
19	5Y1-14216-00	.SCREW	1		
20	30X-14358-00	.NUT	1		
21	14T-14323-00	.SCREW, AIR ADJUSTING	1		
22	1VJ-14197-00	.PIPE	2		
23	1JK-14940-01	.DIAPHRAGM ASSY	1		
24	2JN-14293-00	.COVER 1	1		
25	4PT-14291-00	.BRACKET 1	1		
26	7KF-14227-00	.WASHER	1		
27	92990-04100	.WASHER, SPRING	1		

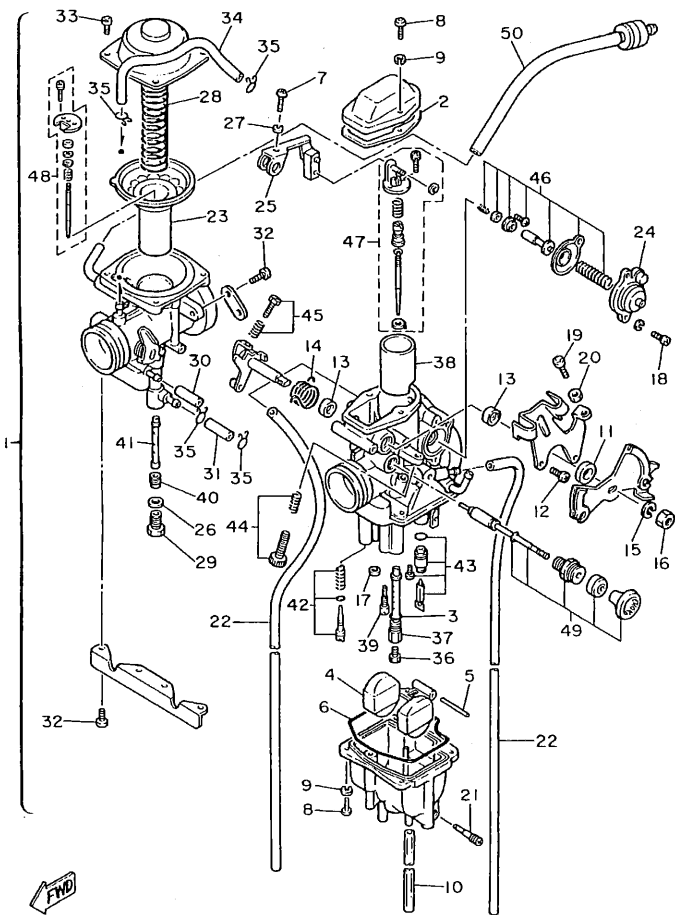

3TB332-0080

FIG. 9 CARBURETOR

REF. NO.	PART NO.	DESCRIPTION	4PT7	4SL4	REMARKS
28	1VJ-14286-00	.SPRING	1		
29	7KF-14162-00	.BOLT, HOLDING	1		
30	5Y1-14349-00	.PIPE	1		
31	30X-14148-00	.PIPE	1		
32	98501-05010	.SCREW, PAN HEAD	6		
33	98501-04010	.SCREW, PAN HEAD	4		
34	5Y1-14149-00	.PIPE	1		
35	5Y1-14159-00	.CLIP	4		
36	288-14343-65	.JET, MAIN (#130)	1		UR STD
	288-14343-60	.JET, MAIN (#120)	1		UR
	288-14343-70	.JET, MAIN (#140)	1		UR
37	2KF-14341-00	.NOZZLE, MAIN	1		
38	1JK-14313-55	.VALVE, THROTTLE 2	1		
39	43F-14342-23	.JET, PILOT (# 46)	1		
40	30X-14343-60	.JET, MAIN (#120)	1		
41	2KF-14355-00	.NOZZLE, MAIN 2	1		
42	51Y-14105-00	.PILOT SCREW SET	1		
43	2JN-14107-00	.NEEDLE VALVE SET	1		
44	3GV-1490K-00	.STOP SCREW SET	1		
45	2NX-14103-00	.THROTTLE SCREW SET	1		
46	1JK-1490A-00	.DIAPHRAGM SET, 1	1		
47	4PT-1490J-10	.NEEDLE SET	1		
48	4PT-1490J-00	.NEEDLE SET	1		
49	2KF-1410A-00	.STARTER SET	1		
50	3TD-14197-00	PIPE	1		

FIG. 10 CARBURETOR 2

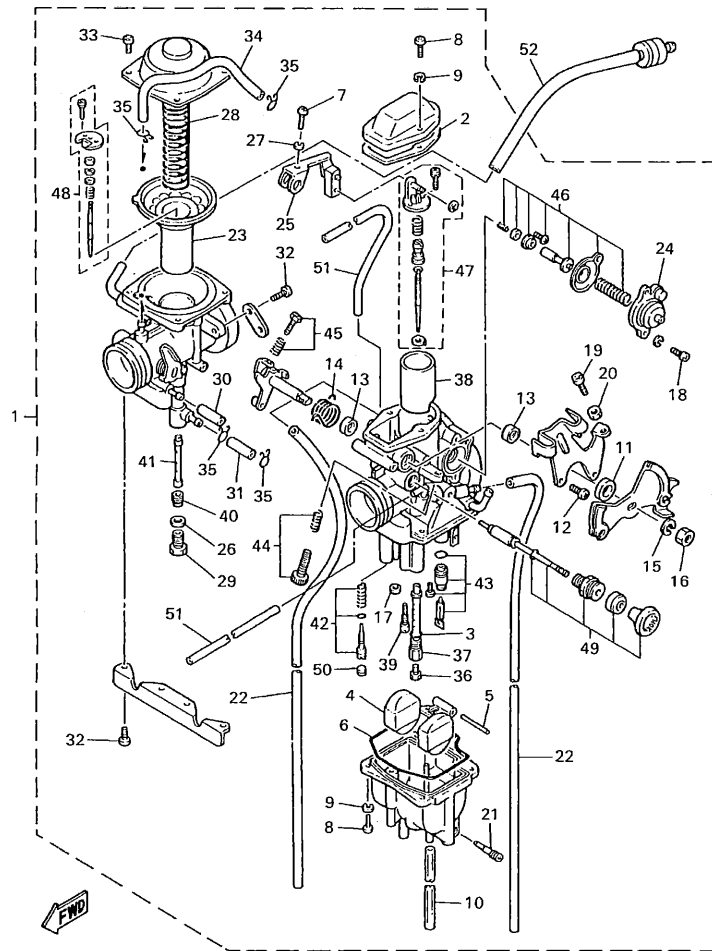

4PT300-7100

REF. NO.	PART NO.	DESCRIPTION	4PT7	4SL4	REMARKS
1	3UX-14301-03	CARBURETOR ASSY 1		1	
2	5Y1-14198-00	.GASKET		1	
3	360-24512-00	.GASKET		2	
4	2JN-14385-00	.FLOAT		1	
5	689-14386-00	.PIN, FLOAT		1	
6	5Y1-14384-00	.GASKET, FLOAT CHAMBER		1	
7	98580-04016	.SCREW, PAN HEAD		1	
8	98501-04014	.SCREW, PAN HEAD		6	
9	92902-04100	.WASHER, SPRING		6	
10	1VJ-14197-00	.PIPE		1	
11	1JK-14357-00	.COLLAR		1	
12	214-24535-00	.SCREW, LEVER FITTING		2	
13	5Y1-14572-00	.PLATE, STAY		2	
14	1JK-14131-01	.SPRING, THROTTLE VALVE		1	
15	5Y1-14356-00	.WASHER, SPRING		1	
16	5Y1-14358-00	.NUT		1	
17	5Y1-14536-00	.GASKET		1	
18	98501-04010	.SCREW, PAN HEAD		2	
19	5Y1-14216-00	.SCREW		1	
20	30X-14358-00	.NUT		1	
21	14T-14323-00	.SCREW, AIR ADJUSTING		1	
22	1VJ-14197-00	.PIPE		2	
23	1JK-14940-01	.DIAPHRAGM ASSY		1	
24	2JN-14293-00	.COVER 1		1	
25	4PT-14291-00	.BRACKET 1		1	
26	7KF-14227-00	.WASHER		1	
27	92990-04100	.WASHER, SPRING		1	

FIG. 10 CARBURETOR 2

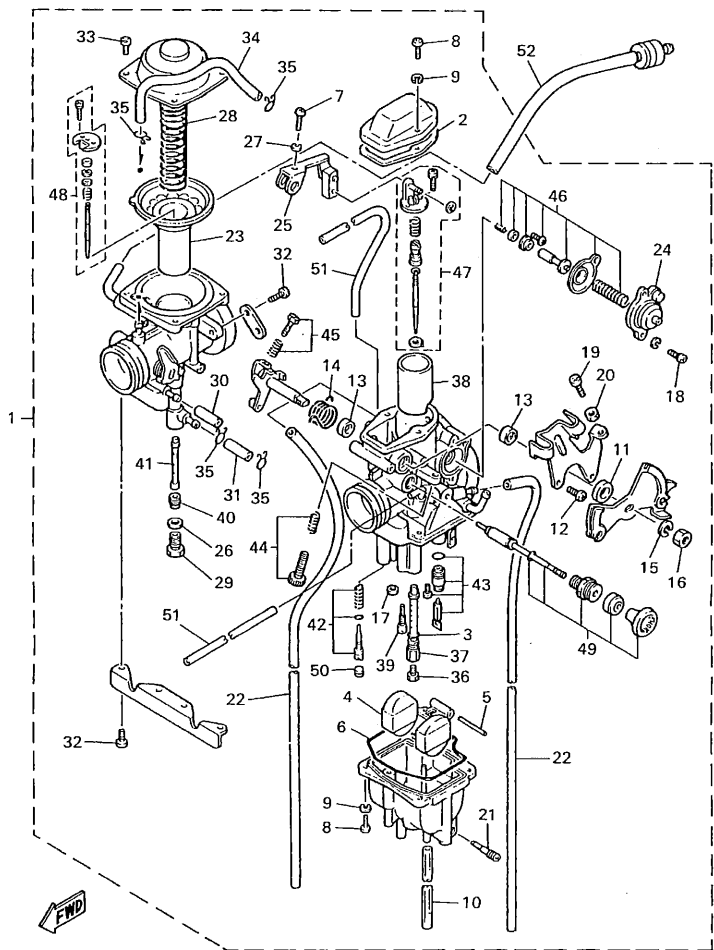

4PT300-7100

REF. NO.	PART NO.	DESCRIPTION	4PT7	4SL4	REMARKS
28	1VJ-14286-00	.SPRING		1	
29	7KF-14162-00	.BOLT, HOLDING		1	
30	5Y1-14349-00	.PIPE		1	
31	30X-14148-00	.PIPE		1	
32	98501-05010	.SCREW, PAN HEAD		6	
33	98501-04010	.SCREW, PAN HEAD		4	
34	5Y1-14149-00	.PIPE		1	
35	5Y1-14159-00	.CLIP		4	
36	288-14343-63	.JET, MAIN (#125)		1	UR STD
	288-14343-61	.JET, MAIN (#122)		1	UR
	288-14343-65	.JET, MAIN (#130)		1	UR
37	2KF-14341-00	.NOZZLE, MAIN		1	
38	1JK-14313-55	.VALVE, THROTTLE 2		1	
39	43F-14342-23	.JET, PILOT (# 46)		1	
40	30X-14343-55	.JET, MAIN (#110)		1	
41	2KF-14355-00	.NOZZLE, MAIN 2		1	
42	51Y-14105-00	.PILOT SCREW SET		1	
43	2JN-14107-00	.NEEDLE VALVE SET		1	
44	3GV-1490K-00	.STOP SCREW SET		1	
45	2NX-14103-00	.THROTTLE SCREW SET		1	
46	1JK-1490A-00	.DIAPHRAGM SET, 1		1	
47	3UX-1490J-10	.NEEDLE SET		1	
48	2KF-1490J-00	.NEEDLE SET		1	
49	2KF-1410A-00	.STARTER SET		1	
50	2WJ-14367-00	.PLUG		1	
51	2WJ-14349-00	.PIPE		2	
52	3LD-14197-00	PIPE		1	

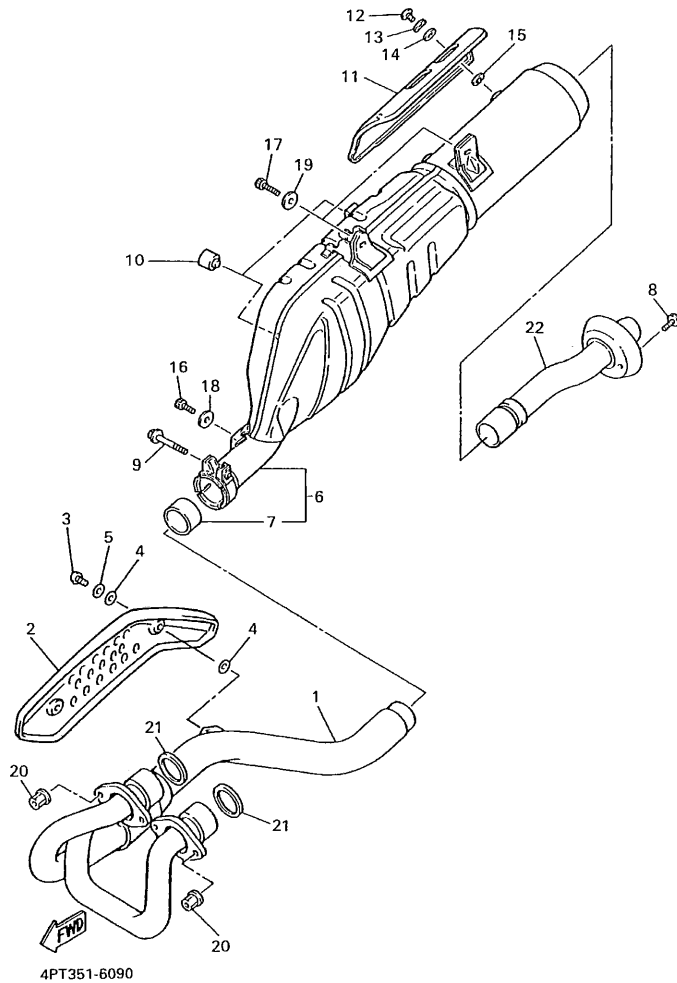
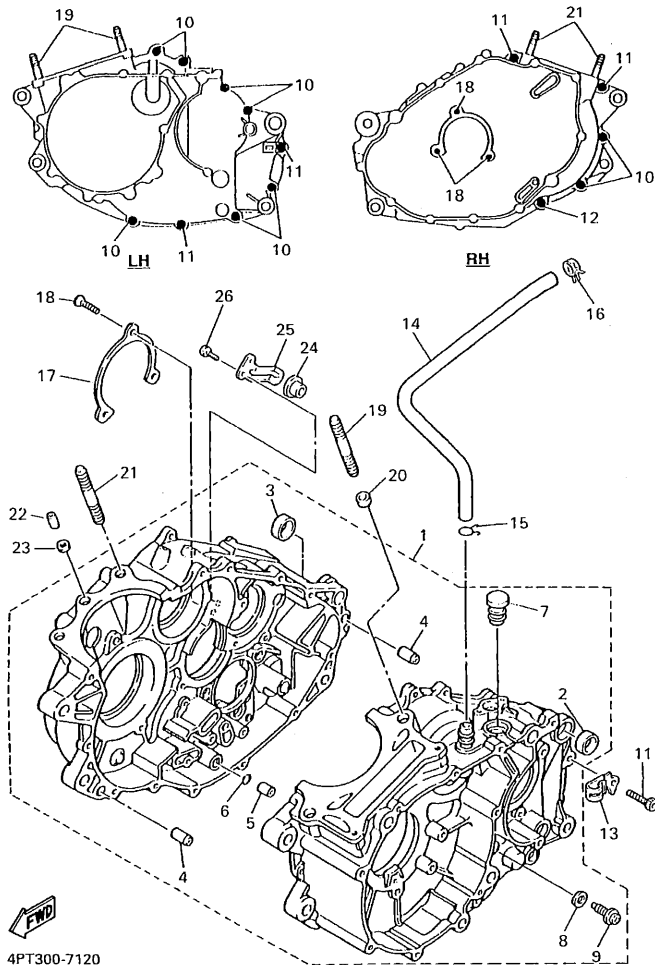

FIG. 11 EXHAUST

REF. NO.	PART NO.	DESCRIPTION	4PT7	4SL4	REMARKS
1	4PT-14611-00	PIPE, EXHAUST 1	1	1	
2	3YF-14628-00	PROTECTOR, EXHAUST PIPE	1	1	
3	92014-06012	BOLT, BUTTON HEAD	2	2	
4	4BD-14766-00	WASHER, PROTECTOR	4	4	
5	92990-06200	WASHER, PLAIN	2	2	
6	4PT-14711-10	MUFFLER 1	1	1	
7	3YF-14755-00	.GASKET, SILENCER	1	1	
8	91317-06012	BOLT	1	1	
9	95027-08040	BOLT, FLANGE	1	1	
10	1UJ-27114-00	STOPPER, MAIN STAND	2	2	
11	3TB-14728-00	PROTECTOR, MUFFLER 2	1	1	
12	98980-06010	SCREW, BIND	2	2	
13	90206-06090	WASHER, WAVE	2	2	
14	4BD-14766-00	WASHER, PROTECTOR	2	2	
15	4BD-14766-00	WASHER, PROTECTOR	2	2	
16	90109-082G0	BOLT	1	1	
17	90105-10186	BOLT, WASHER BASED	2	2	
18	90201-08326	WASHER, PLATE	1	1	
19	90201-102J5	WASHER, PLATE	2	2	
20	90179-06668	NUT	4	4	
21	3YF-14613-01	GASKET, EXHAUST PIPE	2	2	
22	4PT-14752-00	PIPE, OUTLET	1	1	





4PT300-7120

FIG. 12 CRANKCASE

REF. NO.	PART NO.	DESCRIPTION	4PT7	4SL4	REMARKS
1	4PT-15100-11	CRANKCASE ASSY	1	1	
2	90387-17783	.COLLAR	1	1	
3	90387-16782	.COLLAR	1	1	
4	99530-12016	.PIN, DOWEL	2	2	
5	99510-08016	.PIN, DOWEL	1	1	
6	93210-07135	.O-RING	1	1	
7	3YF-15167-00	.PLUG, BLIND 1	1	1	
8	90430-08119	.GASKET	1	1	
9	90149-08067	.SCREW	1	1	
10	91317-06030	BOLT	9	9	
11	91317-06045	BOLT	4	4	
12	91317-06060	BOLT	1	1	
13	90465-08344	CLAMP	1	1	
14	3TB-11166-00	PIPE, BREATHER 1	1	1	
15	90467-14015	CLIP	1	1	
16	90467-17128	CLIP	1	1	
17	5Y1-15383-00	PLATE, BEARING COVER	1	1	
18	98707-06012	SCREW, FLAT HEAD	3	3	
19	90116-10506	BOLT, STUD	2	2	
20	99530-14016	PIN, DOWEL	2	2	
21	90116-10263	BOLT, STUD	2	2	
22	99530-08016	PIN, DOWEL	1	1	
23	90430-08178	GASKET	1	1	
24	3Y6-15167-00	PLUG, BLIND 1	1	1	
25	3Y6-15144-00	PLATE, LOCK	1	1	
26	97027-06016	BOLT	2	2	

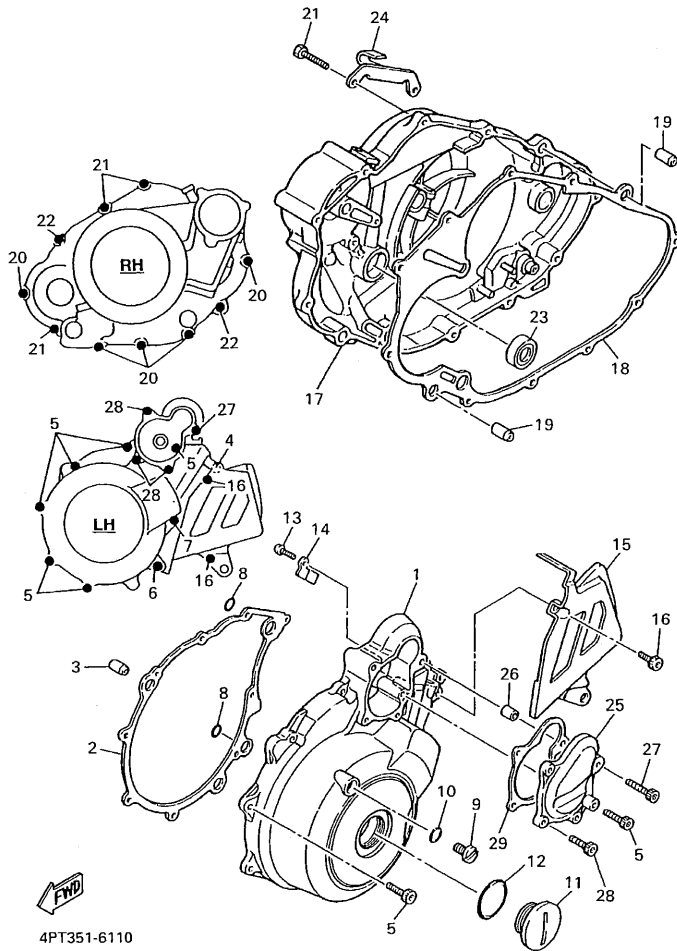
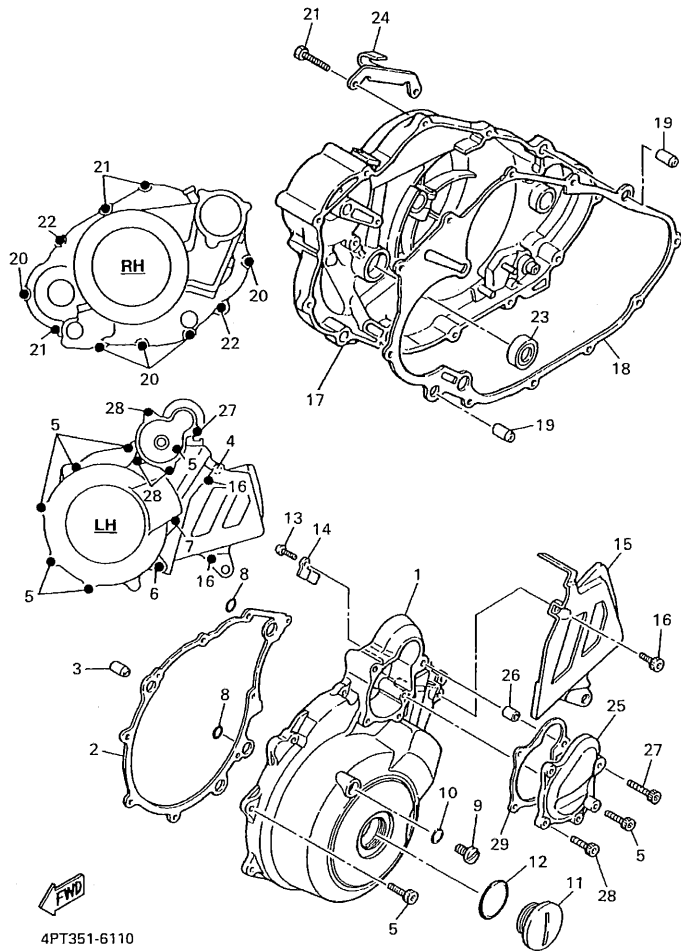

FIG. 13 CRANKCASE COVER 1

REF. NO.	PART NO.	DESCRIPTION	4PT7	4SL4	REMARKS
1	4PT-15411-00	COVER, CRANKCASE 1	1	1	
2	4DW-15451-00	GASKET, CRANKCASE COVER 1	1	1	
3	99530-12016	PIN, DOWEL	2	2	
4	91317-06035	BOLT	1	1	
5	91317-06025	BOLT	6	6	
6	91317-06050	BOLT	1	1	
7	91317-06050	BOLT	1	1	
8	93210-13361	O-RING	2	2	
9	90340-08014	PLUG, STRAIGHT SCREW	1	1	
10	90430-08143	GASKET	1	1	
11	90340-36076	PLUG, STRAIGHT SCREW	1	1	
12	93210-36510	O-RING	1	1	
13	98507-06012	SCREW, PAN HEAD	1	1	
14	90462-16102	CLAMP	1	1	
15	4PT-15421-00	COVER, CRANKCASE 2	1	1	
16	91317-06016	BOLT	2	2	
17	4PT-15431-10	COVER, CRANKCASE 3	1	1	
18	4DW-15462-00	GASKET, CRANKCASE COVER 3	1	1	
19	99530-12016	PIN, DOWEL	2	2	
20	91317-06025	BOLT	5	5	
21	91317-06030	BOLT	3	3	
22	91317-06035	BOLT	2	2	
23	93101-14092	OIL SEAL (S7-14-25-5.5-1-HS)	1	1	
24	3YF-15441-00	HOLDER, CLUTCH CABLE	1	1	
25	4PT-15415-00	COVER, GENERATOR	1	1	
26	99530-08016	PIN, DOWEL	1	1	
27	91317-06035	BOLT	1	1	

FIG. 13 CRANKCASE COVER 1



REF. NO.	PART NO.	DESCRIPTION	4PT7	4SL4	REMARKS
28	91317-06025	BOLT	3	3	
29	4DW-15455-00	GASKET 1	1	1	

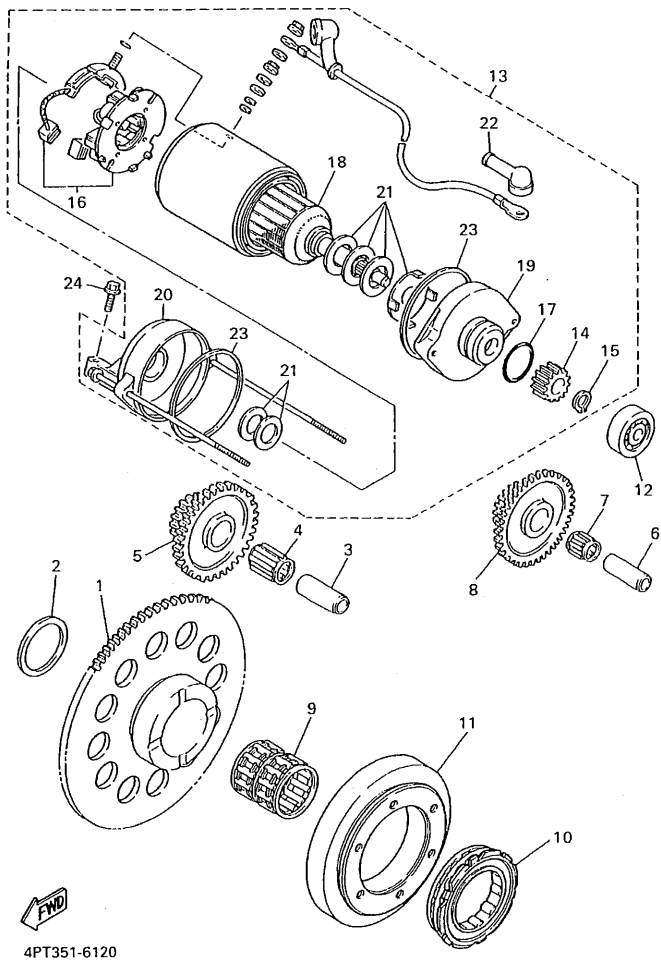

4PT351-6120

FIG. 14 STARTER CLUTCH

REF. NO.	PART NO.	DESCRIPTION	4PT7	4SL4	REMARKS
1	3YF-15515-00	GEAR 3	1	1	
2	90201-303P4	WASHER, PLATE	1	1	
3	1VJ-15522-00	SHAFT 2	1	1	
4	93310-217R7	BEARING	1	1	
5	1VJ-15517-00	GEAR, IDLER 2	1	1	
6	1VJ-15521-00	SHAFT 1	1	1	
7	93310-212R6	BEARING	1	1	
8	1VJ-15512-00	GEAR, IDLER 1	1	1	
9	93310-530C7	BEARING	1	1	
10	3TB-15590-01	STARTER ONE-WAY ASSY	1	1	
11	3TB-15594-00	RACE, ONE-WAY BEARING	1	1	
12	93306-20006	BEARING (B6200)	1	1	NTN
13	3TB-81800-01	STARTING MOTOR ASSY	1	1	
14	1VJ-15511-00	.GEAR, STARTING MOTOR	1	1	
15	93440-11024	.CIRCLIP	1	1	
16	3AJ-81801-00	.BRUSH SET	1	1	
17	1FK-81847-00	.O-RING	1	1	
18	3AJ-81850-00	.ARMATURE ASSY	1	1	
19	3AJ-81830-00	.FRONT BRACKET ASSY	1	1	
20	3AJ-81820-00	.REAR BRACKET ASSY	1	1	
21	3AJ-81809-00	.WASHER KIT	1	1	
22	4G0-81871-00	.CAP	1	1	
23	11H-81844-00	.GASKET	2	2	
24	95817-06030	BOLT, FLANGE	2	2	

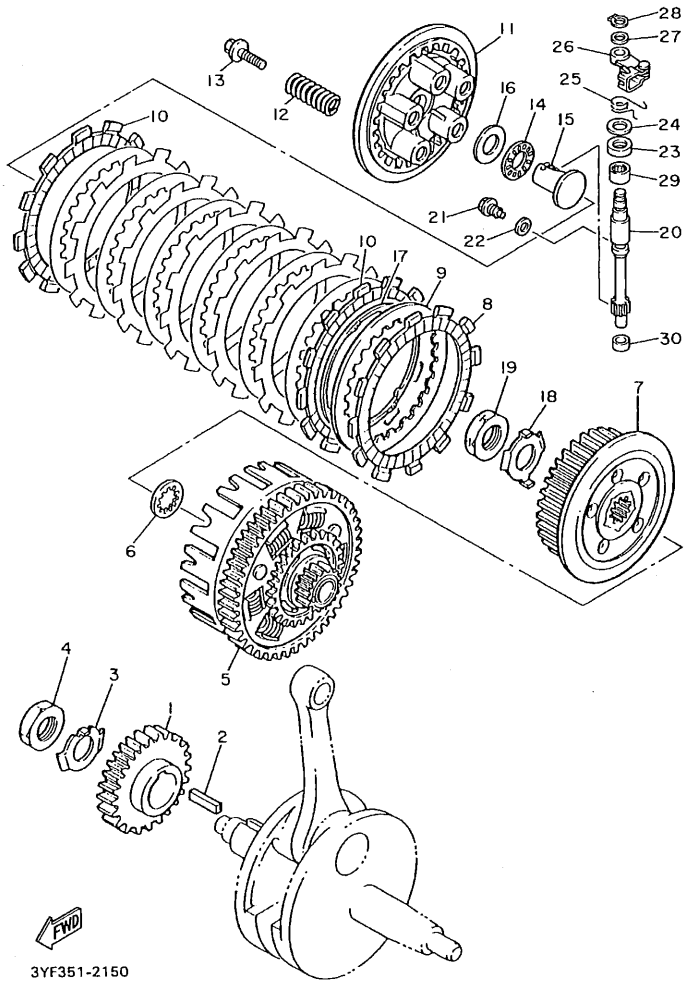
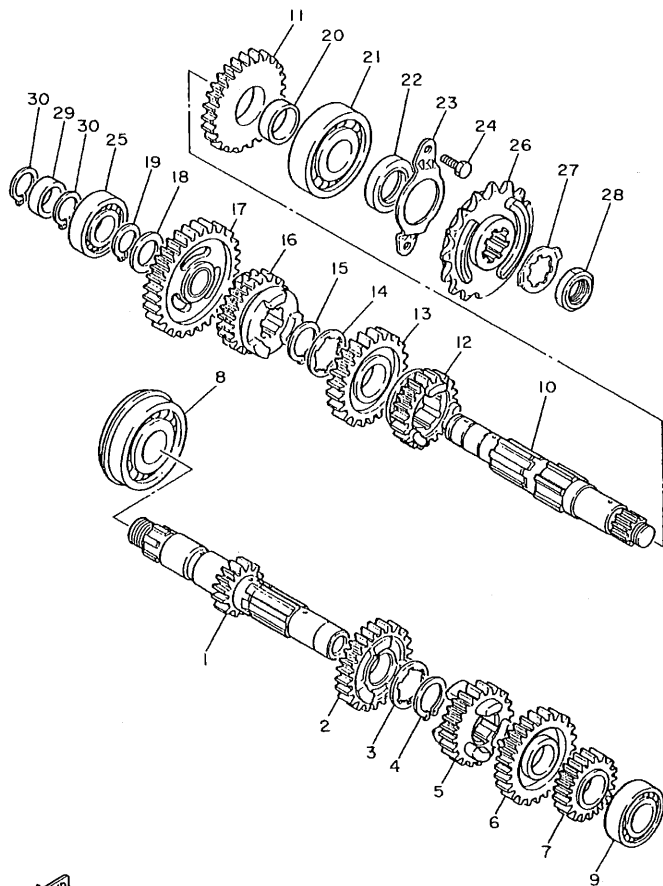

FIG. 15 CLUTCH

REF. NO.	PART NO.	DESCRIPTION	4PT7	4SL4	REMARKS
1	3AJ-16111-00	GEAR, PRIMARY DRIVE (34T)	1	1	
2	90282-07042	KEY, STRAIGHT	1	1	
3	90215-20197	WASHER, LOCK	1	1	
4	90170-20274	NUT	1	1	
5	3AJ-16150-00	PRIMARY DRIVEN GEAR COMP.(71T)	1	1	
6	2JN-16154-00	PLATE, THRUST 1	1	1	
7	4PT-16371-00	BOSS, CLUTCH	1	1	
8	5Y1-16321-00	PLATE, FRICTION	6	6	
9	360-16325-00	PLATE, CLUTCH 2	7	7	
10	5Y1-16331-01	PLATE, FRICTION 2	2	2	
11	3YF-16351-00	PLATE, PRESSURE 1	1	1	
12	90501-23142	SPRING, COMPRESSION	5	5	
13	90159-06092	SCREW, WITH WASHER	5	5	
14	93340-21505	BEARING	1	1	
15	4H7-16356-01	ROD, PUSH 1	1	1	
16	90201-150U6	WASHER, PLATE	1	1	
17	5Y1-16383-00	SPRING, CLUTCH BOSS	1	1	
18	90215-20231	WASHER, LOCK	1	1	
19	90170-20327	NUT	1	1	
20	3JD-16382-00	AXLE, PUSH LEVER	1	1	
21	90109-06418	BOLT	1	1	
22	90430-06014	GASKET	1	1	
23	93102-15212	OIL SEAL	1	1	
24	90201-15785	WASHER, PLATE	1	1	
25	90508-14767	SPRING, TORSION	1	1	
26	3YF-16340-01	PUSH LEVER ASSY	1	1	
27	90201-10119	WASHER, PLATE	1	1	





3YF351-1160

FIG. 16 TRANSMISSION

REF. NO.	PART NO.	DESCRIPTION	4PT7	4SL4	REMARKS
1	3YF-17401-00	MAIN AXLE SUB-ASSY (12T)	1	1	
2	34K-17141-00	GEAR, 4TH PINION(22T)	1	1	
3	90209-22191	WASHER	1	1	
4	93440-25084	CIRCLIP	1	1	
5	1VJ-17131-00	GEAR, 3RD PINION (20T)	1	1	
6	3YF-17151-01	GEAR, 5TH PINION (24T)	1	1	
7	34K-17121-01	GEAR, 2ND PINION (17T)	1	1	
8	93306-30540	BEARING (6305NRX1C3)	1	1	
9	93306-00431	BEARING	1	1	
10	3YF-17402-00	DRIVE AXLE SUB-ASSY (22T)	1	1	
11	2JT-17221-00	GEAR, 2ND WHEEL (27T)	1	1	
12	3YF-17251-01	GEAR, 5TH WHEEL (19T)	1	1	
13	1VJ-17231-00	GEAR, 3RD WHEEL (24T)	1	1	
14	90209-22191	WASHER	1	1	
15	93440-25084	CIRCLIP	1	1	
16	3AJ-17241-00	GEAR, 4TH WHEEL (21T)	1	1	
17	3AJ-17211-00	GEAR, 1ST WHEEL (31T)	1	1	
18	90201-20276	WASHER, PLATE (1.0T)	1	1	
19	99009-20400	CIRCLIP	1	1	
20	3YF-17439-00	SPACER	1	1	
21	93306-30535	BEARING	1	1	
22	93102-25226	OIL SEAL	1	1	
23	5Y1-17471-00	PLATE, COVER	1	1	
24	97027-06014	BOLT	2	2	
25	93306-00426	BEARING	1	1	
26	2NX-17460-01	SPROCKET, DRIVE	1	1	
27	90215-23265	WASHER, LOCK	1	1	





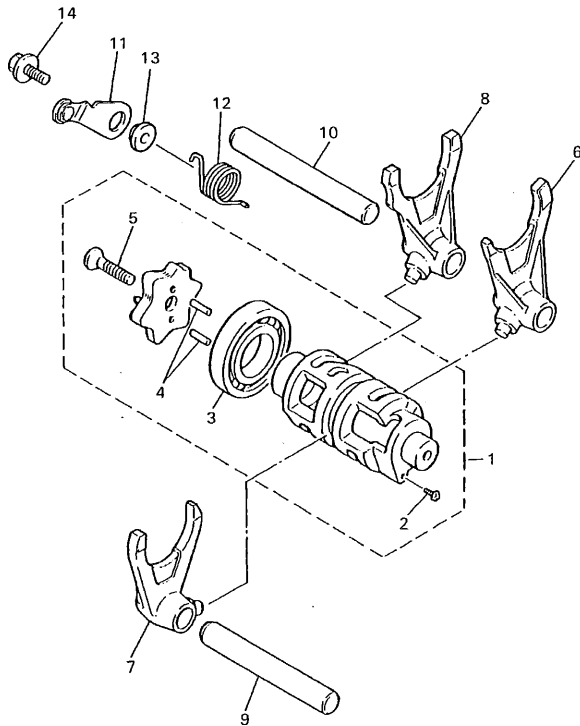

4PT351-5150

FIG. 17 SHIFT CAM. FORK

REF. NO.	PART NO.	DESCRIPTION	4PT7	4SL4	REMARKS
1	3YF-18540-00	SHIFT CAM ASSY	1	1	
2	136-18542-00	.POINT, NEUTRAL	1	1	
3	93316-00501	.BEARING	1	1	
4	93604-10011	.PIN, DOWEL	2	2	
5	90151-06017	.SCREW, COUNTERSUNK	1	1	
6	4PT-18511-00	FORK, SHIFT 1	1	1	
7	4PT-18512-00	FORK, SHIFT 2	1	1	
8	4PT-18513-00	FORK, SHIFT 3	1	1	
9	3YF-18531-00	BAR, SHIFT FORK GUIDE 1	1	1	
10	3XV-18535-00	BAR, SHIFT FORK GUIDE 2	1	1	
11	4PT-18140-00	STOPPER LEVER ASSY	1	1	
12	90508-26691	SPRING, TORSION	1	1	
13	4PT-18175-00	SPACER	1	1	
14	90159-06078	SCREW, WITH WASHER	1	1	

FIG. 18 SHIFT SHAFT

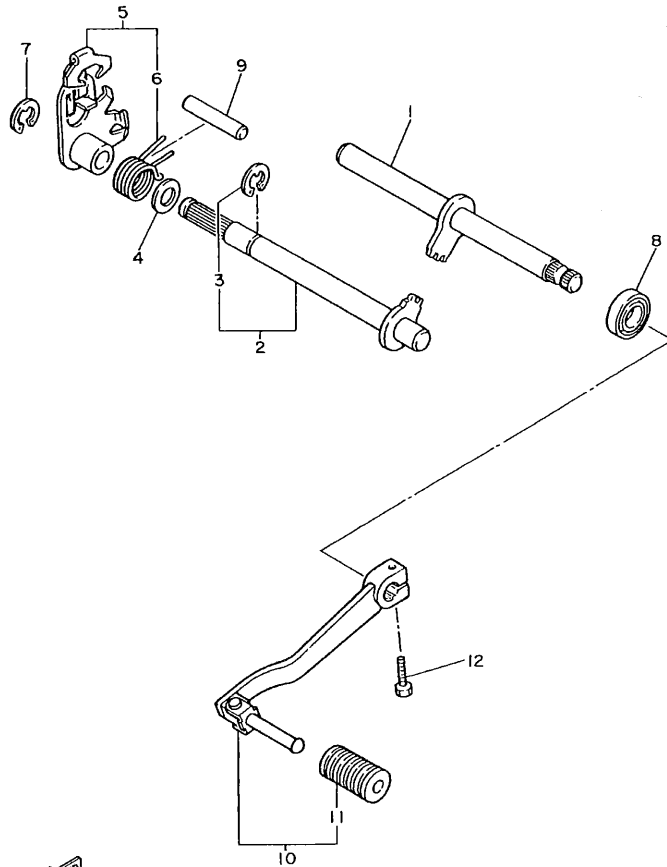

3TB351-0160

REF. NO.	PART NO.	DESCRIPTION	4PT7	4SL4			REMARKS
1	43F-18102-02	SHIFT SHAFT ASSY 2	1	1			
2	5Y1-18101-02	SHIFT SHAFT ASSY	1	1			
3	99001-10600	.CIRCLIP	1	1			
4	90201-12474	WASHER, PLATE	1	1			
5	34K-18120-00	SHIFT LEVER ASSY	1	1			
6	90508-29629	.SPRING, TORSION	1	1			
7	99001-09600	CIRCLIP	1	1			
8	93102-12106	OIL SEAL (SD 12-22-5 HS)	1	1			
9	93608-33046	PIN, DOWEL	1	1			
10	1VJ-18110-01	SHIFT PEDAL ASSY	1	1			
11	1W6-18113-00	.COVER, SHIFT PEDAL	1	1			
12	97027-06020	BOLT	1	1			

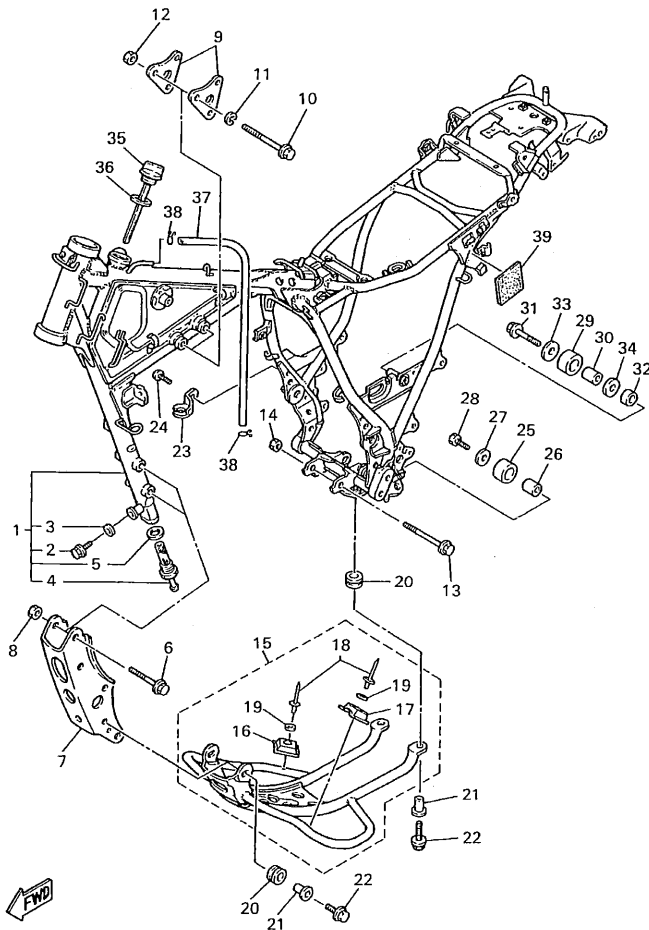

4PT351-5170

FIG. 19 FRAME

REF. NO.	PART NO.	DESCRIPTION	4PT7	4SL4	REMARKS
1	4PT-21110-01-WL	FRAME COMP.	1	1	STDS
2	95807-08012	.BOLT, FLANGE	1	1	
3	90430-08119	.GASKET	1	1	
4	3TB-21756-00	.NET, FILTER	1	1	
5	90430-22123	.GASKET	1	1	
6	95817-10070	BOLT, FLANGE	4	4	
7	3TB-21316-00-90	STAY, ENGINE 3	1	1	ZK
8	95617-10200	NUT, SELF-LOCKING	4	4	
9	34L-21315-00	STAY, ENGINE 2	2	2	
10	97017-10080	BOLT	3	3	
11	92907-10600	WASHER, PLATE	3	3	
12	95617-10200	NUT, SELF-LOCKING	3	3	
13	95817-10100	BOLT, FLANGE	1	1	
14	95617-10200	NUT, SELF-LOCKING	1	1	
15	3TB-W2147-00-WL	PROTECTOR, ENGINE	1	1	STDS
16	34K-21485-00	.DAMPER, RUBBER 1	1	1	
17	34K-21486-00	.DAMPER 2	1	1	
18	90267-40080	.RIVET, BLIND	2	2	
19	92907-04200	.WASHER	2	2	
20	90480-15363	GROMMET	4	4	
21	90387-07391	COLLAR	1	1	
22	95827-06025	BOLT, FLANGE	4	4	
23	5Y1-21441-00	BRACKET, STOP SWITCH	1	1	
24	95027-06010	BOLT, FLANGE	1	1	
25	3TB-22178-00	TENSIONER	1	1	
26	4V4-22184-00	BUSH	1	1	
27	90201-08753	WASHER, PLATE	1	1	

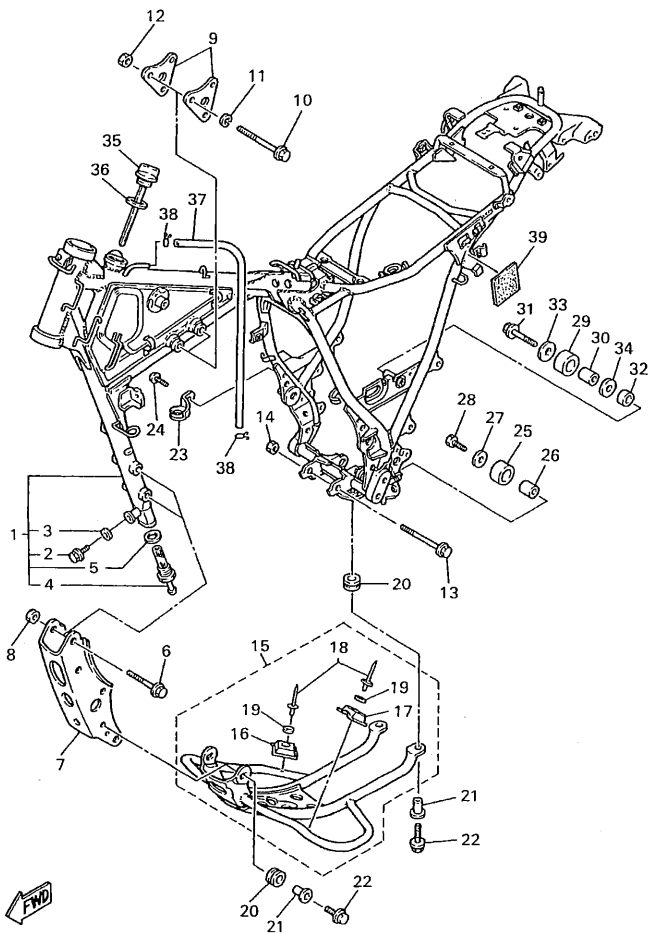

4PT351-5170

FIG. 19 FRAME

REF. NO.	PART NO.	DESCRIPTION	4PT7	4SL4	REMARKS
28	95027-08016	BOLT, FLANGE	1	1	
29	30X-22178-00	TENSIONER	1	1	
30	4V4-22184-00	BUSH	1	1	
31	90109-08705	BOLT	1	1	
32	90201-13409	WASHER, PLATE	1	1	
33	90201-08753	WASHER, PLATE	1	1	
34	90387-085E1	COLLAR	1	1	
35	3TB-21771-00	BODY, CAP	1	1	
36	90430-27124	GASKET	1	1	
37	90445-115J7	HOSE	1	1	
38	90467-10008	CLIP	2	2	
39	3TB-28415-01	DAMPER 1	1	1	

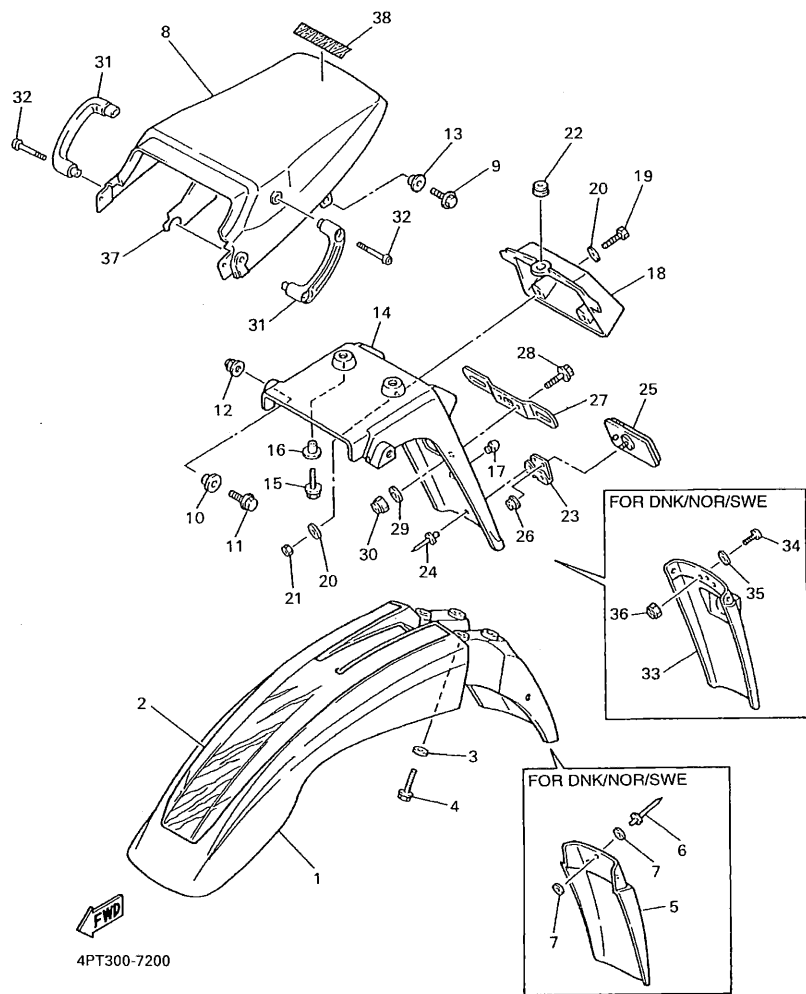
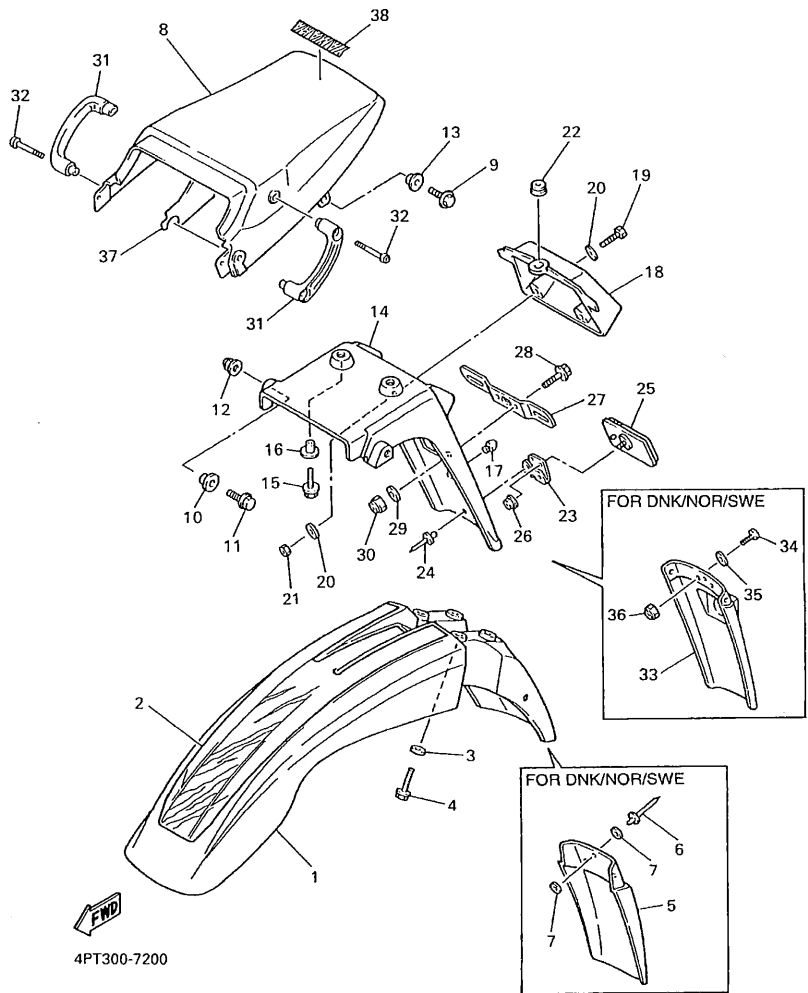

FIG. 20 FENDER

REF. NO.	PART NO.	DESCRIPTION	4PT7	4SL4	REMARKS
1	3RW-21511-60	FENDER, FRONT	1		UR PURPLISH WHITE SOLID 1
	3RW-21511-70	FENDER, FRONT	1		UR YAMAHA BLACK
	3TB-21511-60	FENDER, FRONT	1	1	UR PWS1 FOR DNK, NOR,SWE
	3TB-21511-70	FENDER, FRONT	1	1	UR YB FOR DNK,NOR, SWE
2	4PT-21569-50	GRAPHIC 1	1	1	UR FOR PWS1
	4PT-21569-60	GRAPHIC 1	1	1	UR FOR YB
3	90387-06681	COLLAR	4	4	
4	90119-06097	BOLT, WITH WASHER	4	4	
5	3TB-21521-01	FLAP, FRONT FENDER	1	1	FOR DNK,NOR,SWE
6	90267-32071	RIVET, BLIND	3	3	FOR DNK,NOR,SWE
7	92907-03200	WASHER	6	6	FOR DNK,NOR,SWE
8	4PT-21611-10	FENDER, REAR	1	1	UR PURPLISH WHITE SOLID 1
	4PT-21611-00	FENDER, REAR	1	1	UR YAMAHA BLACK
9	95027-06016	BOLT, FLANGE	2	2	
10	90387-064J1	COLLAR	2	2	
11	90119-06228	BOLT, WITH WASHER	2	2	
12	90176-06085	NUT, CROWN	2	2	
13	90387-06372	COLLAR	2	2	
14	2KF-21685-01	BRACKET, LICENSE	1		UR
	2KF-21685-11	BRACKET, LICENSE	1	1	UR FOR DNK,NOR, SWE
15	90119-06060	BOLT, WITH WASHER	2	2	
16	90387-066M3	COLLAR	2	2	
17	42U-21639-00	DAMPER 2	1	1	
18	4PT-2163A-00	COVER, REAR FENDER 1	1	1	
19	97007-06025	BOLT	2	2	
20	90201-06557	WASHER, PLATE	4	4	
21	95607-06100	NUT, U	2	2	

FIG. 20 FENDER

REF. NO.	PART NO.	DESCRIPTION	4PT7	4SL4	REMARKS
22	90480-13398	GROMMET	1	1	
23	33G-85132-02	BRACKET, REFLECTOR 1	1		EXCEPT FOR DNK, NOR,SWE
24	90267-40110	RIVET, BLIND	2		EXCEPT FOR DNK, NOR,SWE
25	3Y6-85130-02	REAR REFLECTOR ASSY	1	1	
26	95707-05500	NUT, FLANGE	1	1	
27	3YF-84751-00	BRACKET, LICENSE	1	1	
28	95027-06012	BOLT, FLANGE	2	2	
29	90201-064H0	WASHER, PLATE	2	2	
30	95307-06600	NUT	2	2	
31	3TB-2164F-01	STAY 1	2	2	
32	92017-08050	BOLT, BUTTON HEAD	4	4	
33	1VJ-21621-00	FLAP	1	1	FOR DNK,NOR,SWE
34	98507-04012	SCREW, PAN HEAD	4	4	FOR DNK,NOR,SWE
35	92907-04200	WASHER	4	4	FOR DNK,NOR,SWE
36	95607-04100	NUT, U	4	4	FOR DNK,NOR,SWE
37	4PT-2174T-00	INSULATOR, SIDE COVER 2	1	1	
38	99247-00080	EMBLEM, YAMAHA	1	1	



4PT300-7200

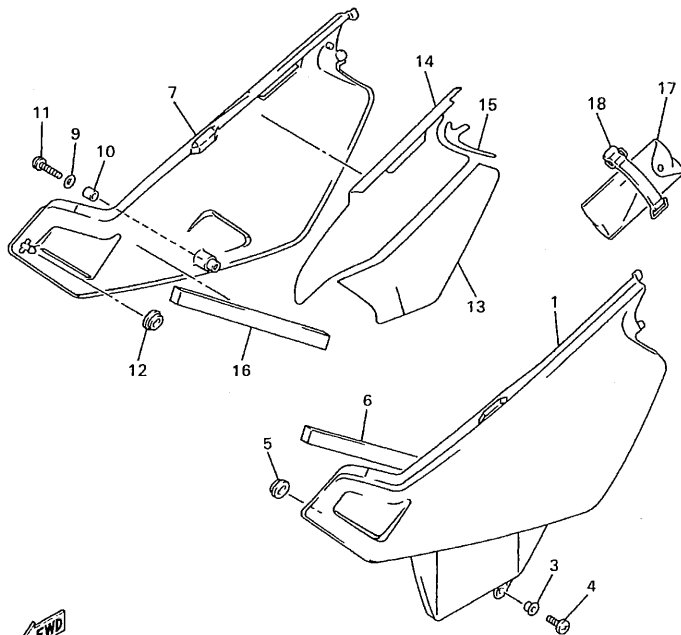
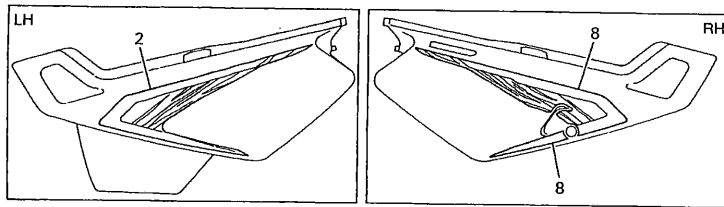

4PT351-5190

FIG. 21 SIDE COVER

REF. NO.	PART NO.	DESCRIPTION	4PT7	4SL4	REMARKS
1	4PT-21711-10	COVER, SIDE 1	1	1	UR PURPLISH WHITE SOLID 1 UR YAMAHA BLACK
	4PT-21711-00	COVER, SIDE 1	1	1	
2	4PT-2173E-50	GRAPHIC 1	1	1	UR FOR PWS1
	4PT-2173E-60	GRAPHIC 1	1	1	UR FOR YB
3	90387-07717	COLLAR	1	1	
4	90149-06223	SCREW	1	1	
5	90480-01141	GROMMET	1	1	
6	4PT-21717-00	DAMPER	1	1	
7	4PT-21721-10	COVER, SIDE 2	1	1	UR PURPLISH WHITE SOLID 1 UR YAMAHA BLACK
	4PT-21721-00	COVER, SIDE 2	1	1	
8	4PT-2174L-50	GRAPHIC SET 2	1	1	UR FOR PWS1
	4PT-2174L-60	GRAPHIC SET 2	1	1	UR FOR YB
9	90201-06055	WASHER, PLATE	1	1	
10	90387-06026	COLLAR	1	1	
11	98907-06020	SCREW, BIND	1	1	
12	90480-01141	GROMMET	1	1	
13	4PT-2174A-00	INSULATOR, SIDE COVER	1	1	
14	4PT-2174A-10	INSULATOR, SIDE COVER	1	1	
15	4PT-2174A-20	INSULATOR, SIDE COVER	1	1	
16	4PT-21717-00	DAMPER	1	1	
17	3TB-28100-00	TOOL KIT	1	1	
18	46X-21376-00	BAND, TOOL	1	1	

FIG. 22 REAR ARM

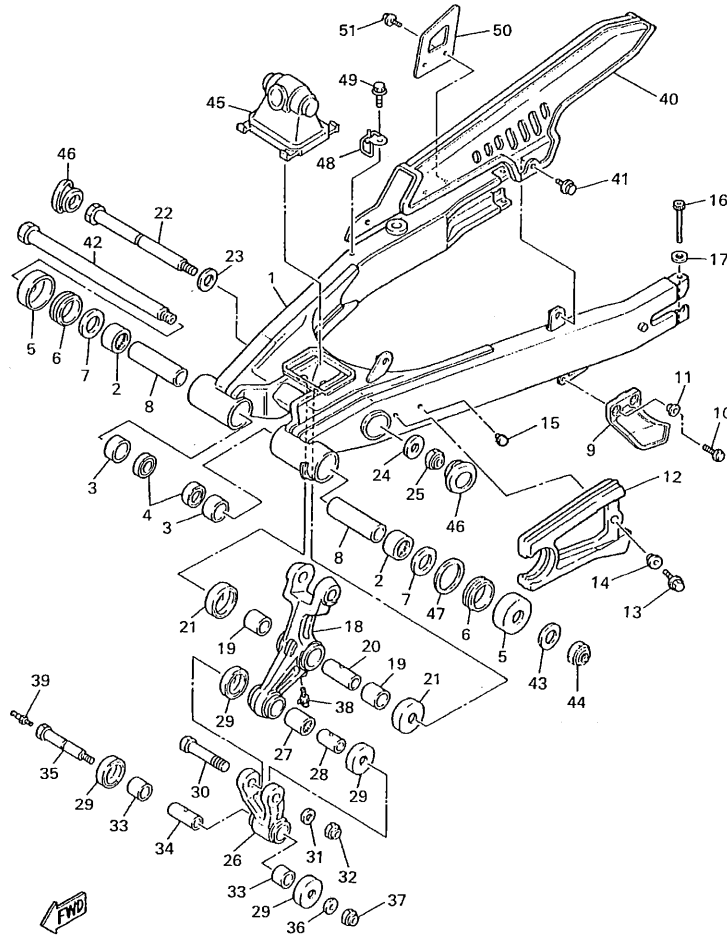

4PT351-6200

REF. NO.	PART NO.	DESCRIPTION			REMARKS
			4PT7	4SL4	
1	4PT-22110-00-35	REAR ARM COMP.	1	1	SL
2	93315-22251	BEARING	2	2	
3	90380-22111	BUSH, SOLID	2	2	
4	93106-22019	OIL SEAL (DC 22-28-8)	2	2	
5	2K6-22128-01	COVER, THRUST 1	2	2	
6	93108-35004	OIL SEAL (35-41-8)	2	2	
7	90201-244A8	WASHER, PLATE (1.95T)	2	2	
8	1VJ-22123-00	BUSH 1	2	2	
9	38V-22199-00	SUPPORT, CHAIN	1	1	
10	97007-06020	BOLT	2	2	
11	90387-06737	COLLAR	2	2	
12	4PT-22151-00	SEAL, GUARD	1	1	
13	95807-06016	BOLT, FLANGE	1	1	
14	90387-07789	COLLAR	1	1	
15	90338-06143	PLUG	1	1	
16	91317-06060	BOLT	2	2	
17	92907-06600	WASHER, PLATE	2	2	
18	3TB-2217A-00	ARM, RELAY	1	1	
19	90386-20120	BUSH	2	2	
20	90380-14095	BUSH, SOLID	1	1	
21	34L-22128-00	COVER, THRUST 1	2	2	
22	90105-12668	BOLT, WASHER BASED	1	1	
23	90201-140G9	WASHER, PLATE	1	1	
24	90201-120A5	WASHER, PLATE	1	1	
25	95617-12100	NUT, U	1	1	
26	34L-2217F-00	ROD, CONNECTING 1	1	1	
27	93315-31750	BEARING	1	1	



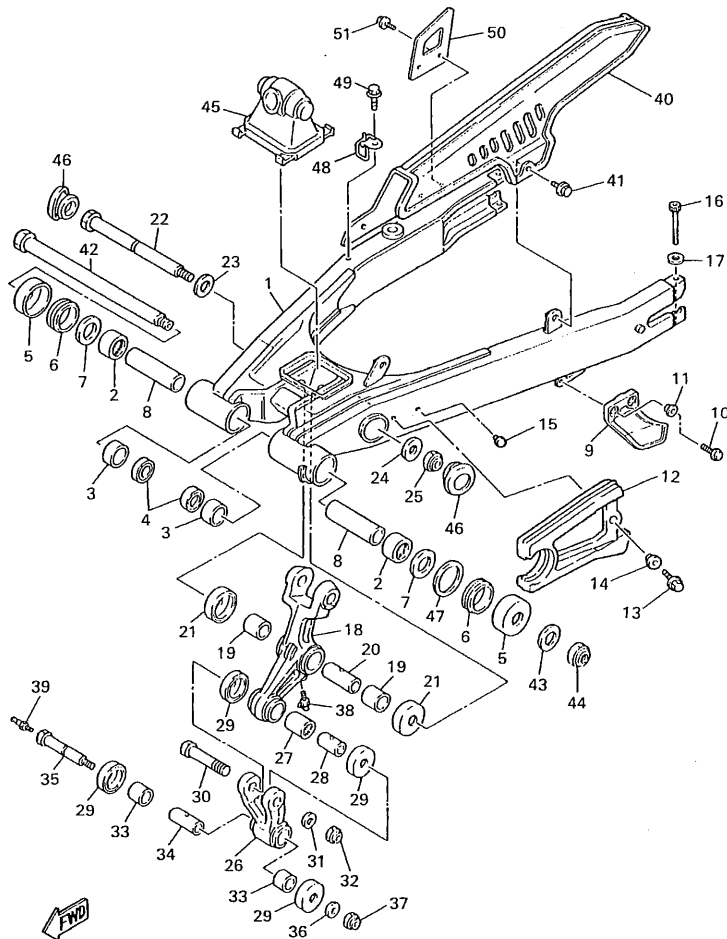

4PT351-6200

FIG. 22 REAR ARM

REF. NO.	PART NO.	DESCRIPTION	4PT7	4SL4	REMARKS
28	90387-1206D	COLLAR	1	1	
29	23X-22129-00	COVER, THRUST 2	4	4	
30	90101-12498	BOLT	1	1	
31	90201-12699	WASHER, PLATE	1	1	
32	95617-12100	NUT, U	1	1	
33	90386-20123	BUSH	2	2	
34	90387-122J6	COLLAR	1	1	
35	90109-102G8	BOLT	1	1	
36	90201-10430	WASHER, PLATE	1	1	
37	90185-10060	NUT, SELF-LOCKING	1	1	
38	93700-06005	NIPPLE, GREASE	1	1	
39	93700-06004	NIPPLE, GREASE	1	1	
40	3TB-22311-00	CASE, CHAIN	1	1	
41	90119-06228	BOLT, WITH WASHER	2	2	
42	1VJ-22141-00	SHAFT, PIVOT	1	1	
43	90201-15238	WASHER, PLATE	1	1	
44	90185-14070	NUT, SELF-LOCKING	1	1	
45	3TB-22189-00	BOOT, RUBBER	1	1	
46	34L-22117-00	CAP	2	2	
47	90201-251F6	WASHER, PLATE (0.3T)	1	1	
48	4PT-25876-00	HOLDER, BRAKE HOSE 2	1	1	
49	95807-06012	BOLT, FLANGE	1	1	
50	2KF-27491-00	PROTECTOR	1	1	
51	95807-06010	BOLT, FLANGE	2	2	

FIG. 23 REAR SUSPENSION

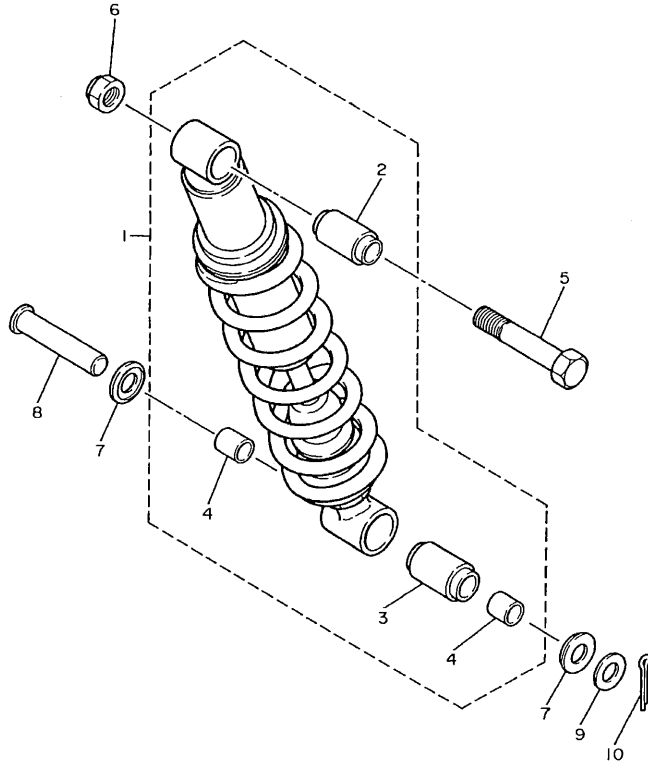

3TB351-0210

REF. NO.	PART NO.	DESCRIPTION	4PT7	4SL4		REMARKS
1	4PT-22210-00-33	SHOCK ABSORBER ASSY, REAR	1	1		YB
2	34L-22216-00	.BUSH, REAR SHOCK ABSORBER	1	1		
3	34L-22226-01	.BUSH, SHOCK ABSORBER LOWER	1	1		
4	90380-14130	.BUSH, SOLID	2	2		
5	90101-12295	BOLT	1	1		
6	95617-12100	NUT, U	1	1		
7	34L-22129-00	COVER, THRUST 2	2	2		
8	90240-14106	PIN, CLEVIS	1	1		
9	92907-14600	WASHER	1	1		
10	91401-30025	PIN, COTTER	1	1		

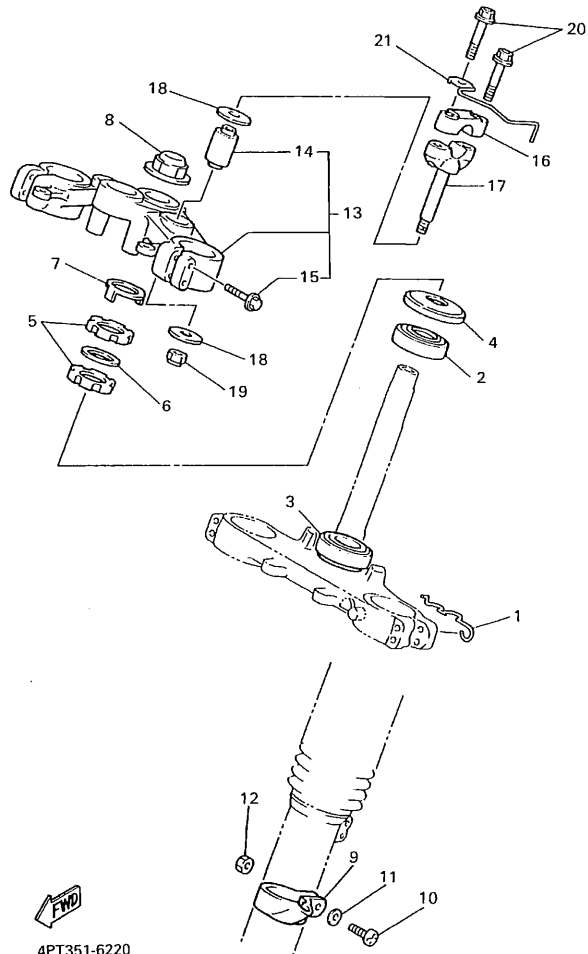

4PT351-6220

FIG. 24 STEERING

REF. NO.	PART NO.	DESCRIPTION	4PT7	4SL4	REMARKS
1	3TB-2331E-00	GUIDE, CABLE	1	1	
2	93332-00001	BEARING	1	1	
3	93332-00008	BEARING	1	1	
4	1W1-23416-00	COVER, BALL RACE 2	1	1	
5	90179-25615	NUT	2	2	
6	90202-26142	WASHER, PLATE	1	1	
7	3YF-23418-00	WASHER, SPECIAL	1	1	
8	90176-22050	NUT, CROWN	1	1	
9	3LD-23318-00	HOLDER, CABLE 1	1	1	
10	98507-05020	SCREW, PAN HEAD	1	1	
11	92907-05600	WASHER, PLATE	1	1	
12	95307-05600	NUT	1	1	
13	4PT-Y2343-00	CROWN, HANDLE	1	1	
14	5A8-23434-01	.HOLDER, DAMPER	2	2	
15	95027-08040	.BOLT, FLANGE	4	4	
16	1E6-23441-10-98	HOLDER, HANDLE UPPER	2	2	LGB
17	3Y6-23442-00-98	HOLDER, HANDLE LOWER	2	2	LGB
18	90201-10141	WASHER, PLATE	4	4	
19	95607-10100	NUT, U	2	2	
20	95827-08035	BOLT, FLANGE	4	4	
21	4PT-23389-10	GUIDE, CABLE	1	1	

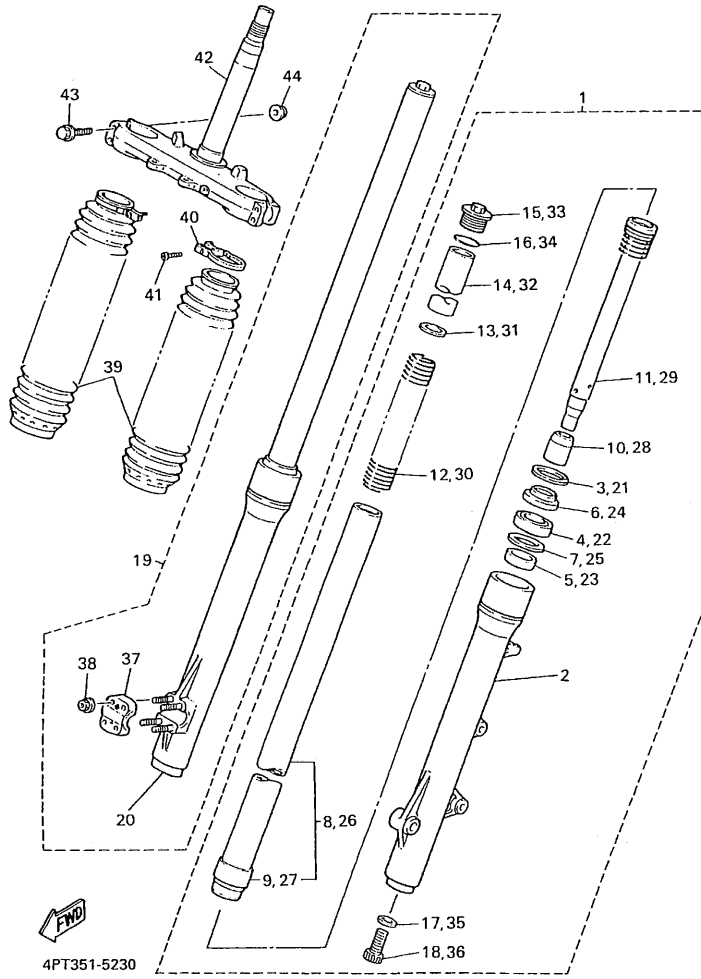

FIG. 25 FRONT FORK

REF. NO.	PART NO.	DESCRIPTION	4PT7	4SL4	REMARKS
1	4PT-23102-00	FRONT FORK ASSY (L.H)	1	1	
2	4PT-23126-00	.TUBE, OUTER (LEFT)	1	1	
3	26H-23156-00	.CLIP, OIL SEAL	1	1	
4	3BN-23145-00	.OIL SEAL	1	1	
5	3JD-23125-L0	.METAL, SLIDE 1	1	1	
6	43F-23144-10	.SEAL, DUST	1	1	
7	36Y-23146-10	.WASHER, OIL SEAL	1	1	
8	4PT-23110-00	.INNER TUBE COMP.1	1	1	
9	3JD-23171-L0	.METAL, SLIDE	1	1	
10	3GM-23173-00	.SPINDLE, TAPER	1	1	
11	4PT-23170-00	.CYLINDER COMP., FRONT FORK	1	1	
12	4PT-23141-00	.SPRING, FRONT FORK	1	1	
13	4DW-23149-40	.WASHER, SPRING UPPER	1	1	
14	4PT-23118-00	.SPACER	1	1	
15	3EN-23111-50	.BOLT, CAP	1	1	
16	43F-23188-10	.O-RING	1	1	
17	509-23158-L0	.GASKET	1	1	
18	278-23181-50	.BOLT, HEXAGON SOCKET HEAD	1	1	
19	4PT-23103-00	FRONT FORK ASSY (R.H)	1	1	
20	4PT-23136-00	.TUBE, OUTER (RIGHT)	1	1	
21	26H-23156-00	.CLIP, OIL SEAL	1	1	
22	3BN-23145-00	.OIL SEAL	1	1	
23	3JD-23125-L0	.METAL, SLIDE 1	1	1	
24	43F-23144-10	.SEAL, DUST	1	1	
25	36Y-23146-10	.WASHER, OIL SEAL	1	1	
26	4PT-23110-00	.INNER TUBE COMP.1	1	1	
27	3JD-23171-L0	.METAL, SLIDE	1	1	

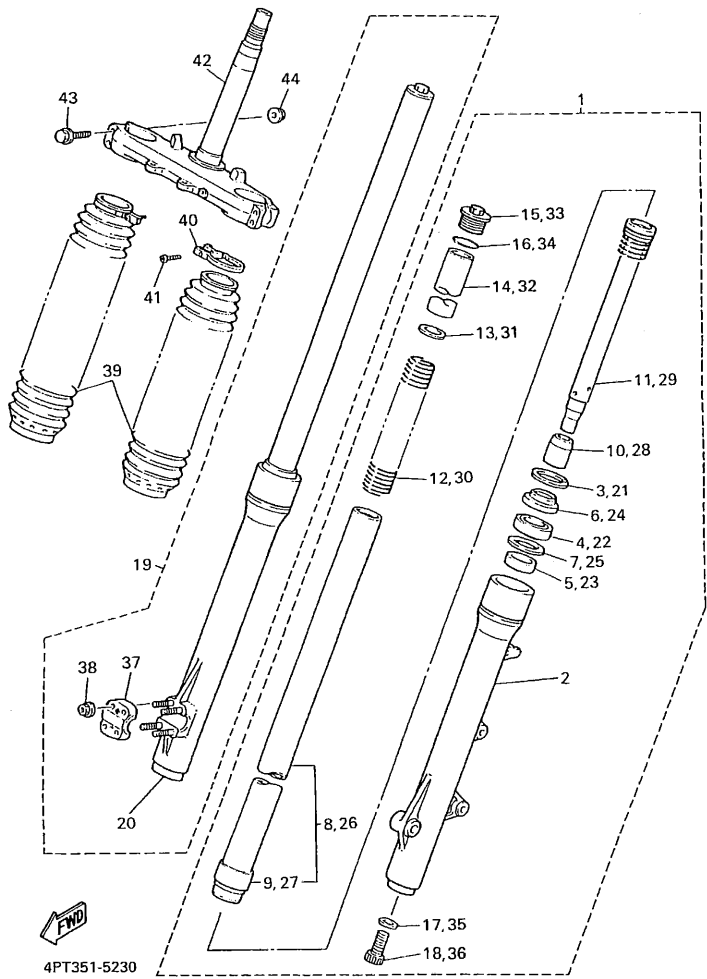
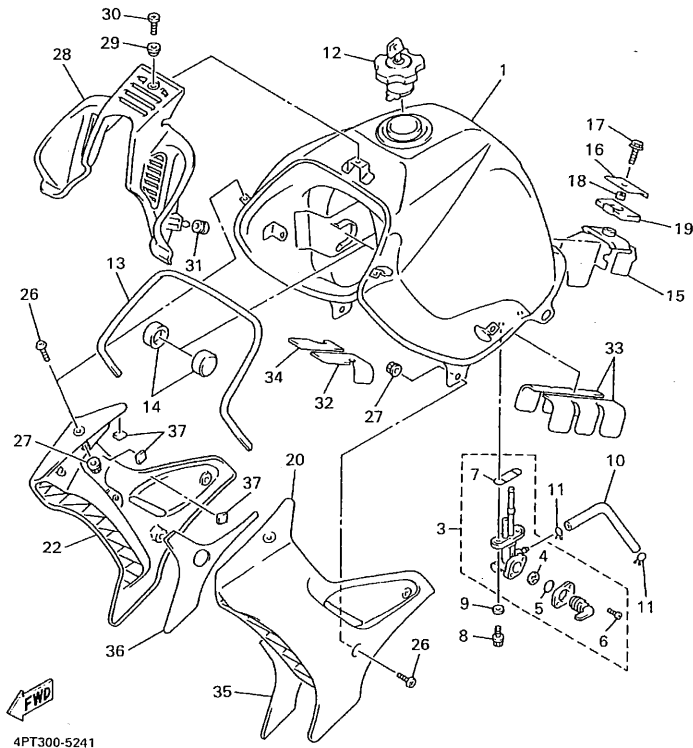
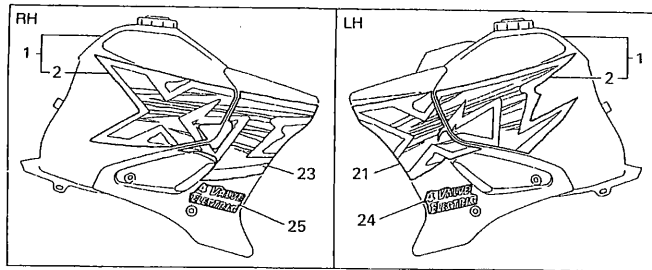

FIG. 25 FRONT FORK

REF. NO.	PART NO.	DESCRIPTION	4PT7	4SL4	REMARKS
28	3GM-23173-00	.SPINDLE, TAPER	1	1	
29	4PT-23170-00	.CYLINDER COMP., FRONT FORK	1	1	
30	4PT-23141-00	.SPRING, FRONT FORK	1	1	
31	4DW-23149-40	.WASHER, SPRING UPPER	1	1	
32	4PT-23118-00	.SPACER	1	1	
33	3EN-23111-50	.BOLT, CAP	1	1	
34	43F-23188-10	.O-RING	1	1	
35	509-23158-L0	.GASKET	1	1	
36	278-23181-50	.BOLT, HEXAGON SOCKET HEAD	1	1	
37	3XJ-23167-L0	.HOLDER, AXLE	1	1	
38	2KF-23127-01	.NUT, OUTER TUBE	4	4	
39	3TB-23191-11	BOOT	2	2	BLACK
40	43M-23192-L0	BAND	2	2	
41	98506-04016	SCREW, PAN HEAD	2	2	
42	4PT-23340-00	UNDER BRACKET COMP.	1	1	
43	95821-08055	BOLT, FLANGE	4	4	
44	95701-08500	NUT, FLANGE	4	4	



4PT300-5241

FIG. 26 FUEL TANK

REF. NO.	PART NO.	DESCRIPTION	APT7	ASL4	REMARKS
1	4PT-24110-10-07	FUEL TANK COMP.	1	1	UR FBL FOR PWS1
	4PT-24110-10-06	FUEL TANK COMP.	1	1	UR VRC7 FOR YB
2	4PT-24240-50	.GRAPHIC SET	1	1	UR FOR PWS1
	4PT-24240-60	.GRAPHIC SET	1	1	UR FOR YB
3	3FY-24500-00	FUEL COCK ASSY 1	1	1	
4	3AJ-24523-00	.VALVE PACKING	1	1	
5	3AJ-24534-00	.SEAL, COCK	1	1	
6	97801-03008	.SCREW, PAN HEAD	2	2	
7	4X8-24512-00	.O-RING	1	1	
8	95027-06016	BOLT, FLANGE	2	2	
9	90202-05193	WASHER, PLATE	2	2	
10	90445-10458	HOSE	1	1	
11	90467-09006	CLIP	2	2	
12	11H-24602-03	CAP ASSY	1	1	
13	3TB-24188-00	MOLD, FUEL TANK	1	1	
14	3TB-24181-00	DAMPER, LOCATING 1	2	2	
15	4PT-24182-00	DAMPER, LOCATING 2	1	1	
16	30X-24186-01	WASHER, SPECIAL	1	1	
17	95807-06016	BOLT, FLANGE	1	1	
18	90387-062E2	COLLAR	1	1	
19	30X-24183-01	DAMPER, LOCATING 3	1	1	
20	4PT-2137W-20	SCOOP, AIR 1	1	1	UR FRENCH BLUE
	4PT-2137W-01	SCOOP, AIR 1	1	1	UR YAMAHA BLACK
21	4PT-24246-50	GRAPHIC 3	1	1	UR FOR PWS1
	4PT-24246-60	GRAPHIC 3	1	1	UR FOR YB
22	4PT-2137X-20	SCOOP, AIR 2	1	1	UR FRENCH BLUE
	4PT-2137X-01	SCOOP, AIR 2	1	1	UR YAMAHA BLACK

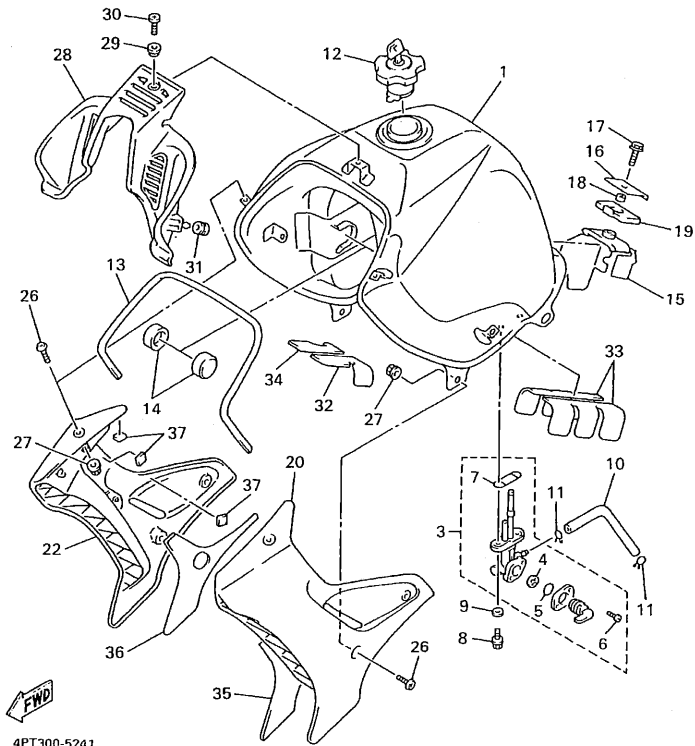
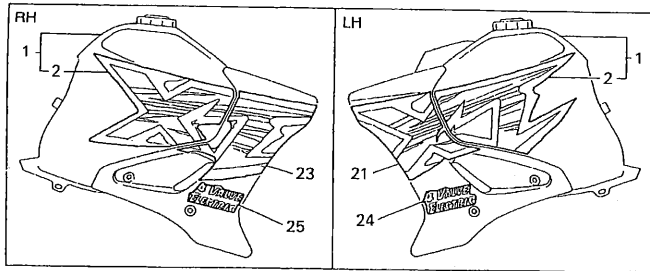
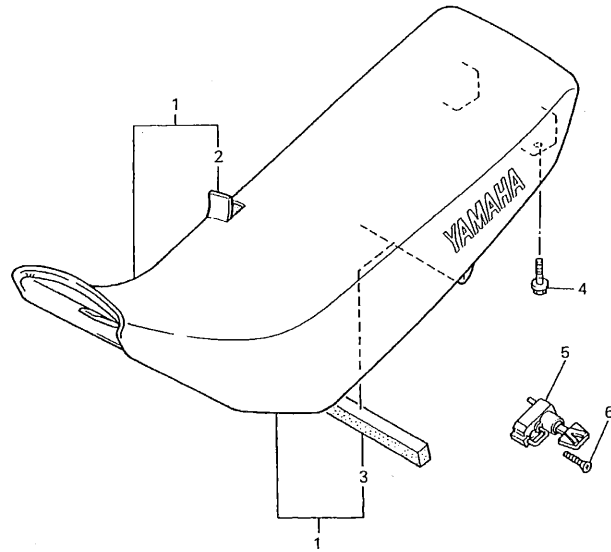

FIG. 26 FUEL TANK

REF. NO.	PART NO.	DESCRIPTION	4PT7	4SL4	REMARKS
23	4PT-24247-50	GRAPHIC	1	1	UR FOR PWS1
	4PT-24247-60	GRAPHIC	1	1	UR FOR YB
24	4PT-24161-20	EMBLEM 1	1	1	UR FOR PWS1
	4PT-24161-40	EMBLEM 1	1	1	UR FOR YB
25	4PT-24162-20	EMBLEM 2	1	1	UR FOR PWS1
	4PT-24162-40	EMBLEM 2	1	1	UR FOR YB
26	90149-05299	SCREW	6	6	
27	90179-05523	NUT	6	6	
28	3TB-2137Y-00	GUIDE, AIR	1	1	
29	90387-064J1	COLLAR	1	1	
30	90149-06223	SCREW	1	1	
31	90480-13428	GROMMET	2	2	
32	4PT-2416F-00	INSULATOR, FUEL TANK 1	1	1	
33	4PT-2416G-00	INSULATOR, FUEL TANK 2	2	2	
34	4PT-2416F-10	INSULATOR, FUEL TANK 1	1	1	
35	4PT-2414H-00	DAMPER, PLATE 1	1	1	
36	4PT-2414J-00	DAMPER, PLATE 2	1	1	
37	34M-2139X-00	DAMPER	6	6	

FIG. 27 SEAT



REF. NO.	PART NO.	DESCRIPTION	4PT7	4SL4			REMARKS
1	4PT-24770-30	SEMI-DOUBLE SEAT ASSY	1	1			UR FOR PWS1
	4PT-24770-40	SEMI-DOUBLE SEAT ASSY	1	1			UR FOR YB
2	4PT-24731-30	.COVER, SEAT	1	1			UR FOR PWS1
	4PT-24731-40	.COVER, SEAT	1	1			UR FOR YB
3	3TB-24723-00	.DAMPER, SEAT	1	1			
4	90119-06063	BOLT, WITH WASHER	2	2			
5	4R8-21308-00	HELMET HANGER ASSY	1	1			
6	90149-06154	SCREW	1	1			

  
4PT351-5250



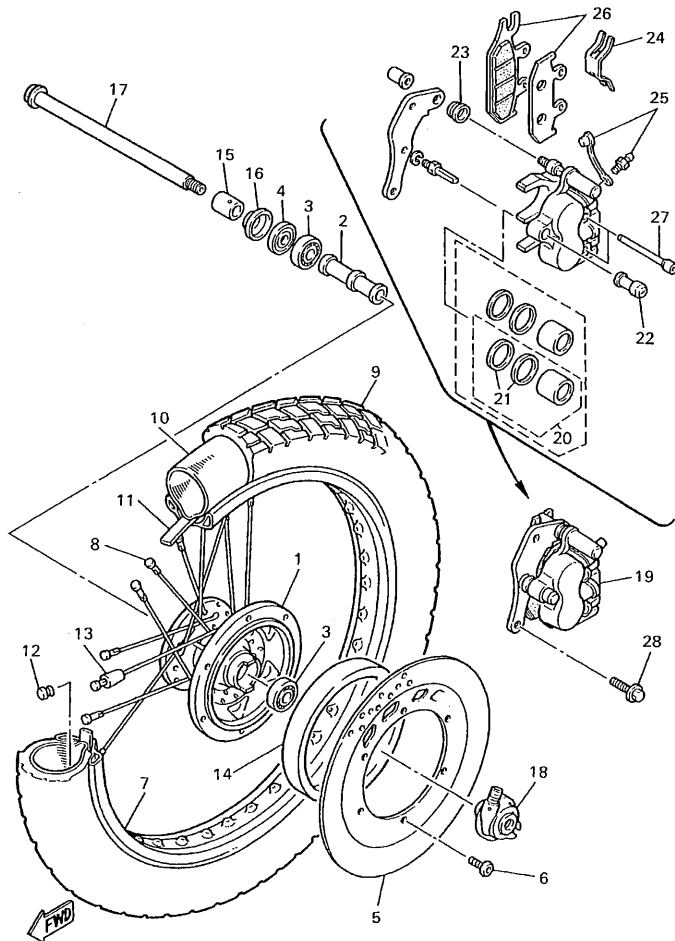

4PT351-5260

FIG. 28 FRONT WHEEL

REF. NO.	PART NO.	DESCRIPTION	4PT7	4SL4	REMARKS
1	3YF-25111-00-98	HUB, FRONT	1	1	LGB
2	90560-15240	SPACER	1	1	
3	93306-20205	BEARING (B6202)	2	2	
4	93102-20281	OIL SEAL (SD 20-35-5)	1	1	
5	3LP-2582T-00	DISC, BRAKE	1	1	
6	90109-081F0	BOLT	6	6	
7	94418-21492	RIM (1.85-21)	1	1	
8	3TB-25104-00	SPOKE SET, FRONT	1	1	
9	94109-2108C	TIRE (MCS 90/90-21 54S TW47)	1	1	UR BRIDGESTONE
	94109-2109R	TIRE (90/90-21 54S TRAILMAX)	1	1	UR DUNLOP
10	94209-21277	TUBE (MCS 90/90-21 TR-4)	1	1	UR BRIDGESTONE
	94227-21101	TUBE (80/100-21 TR4 BTL)	1	1	UR DUNLOP
11	94330-21084	BAND, RIM (3.00-21)	1	1	BRIDGESTONE
12	90338-09130	PLUG	1	1	
13	156-25398-00	BALANCER, WHEEL	1	1	UN
14	4PT-25336-00	RING 2	1	1	
15	90387-152J3	COLLAR	1	1	
16	322-25118-00	COVER, HUB DUST	1	1	
17	55U-25181-01	AXLE, WHEEL	1	1	
18	34L-25190-01	GEAR UNIT ASSY	1	1	
19	4PT-2580T-00	CALIPER ASSY (LEFT)	1	1	
20	3TB-W0057-00	.PISTON ASSY, CALIPER	2	2	
21	3GD-W0047-00	..CALIPER SEAL KIT	2	2	
22	1UY-25937-51	.BOOT 2	1	1	
23	3JD-25917-00	.BOOT, CALIPER	1	1	
24	3TB-25919-00	.SUPPORT, PAD	1	1	
25	1UY-W0048-50	.BLEED SCREW KIT	1	1	

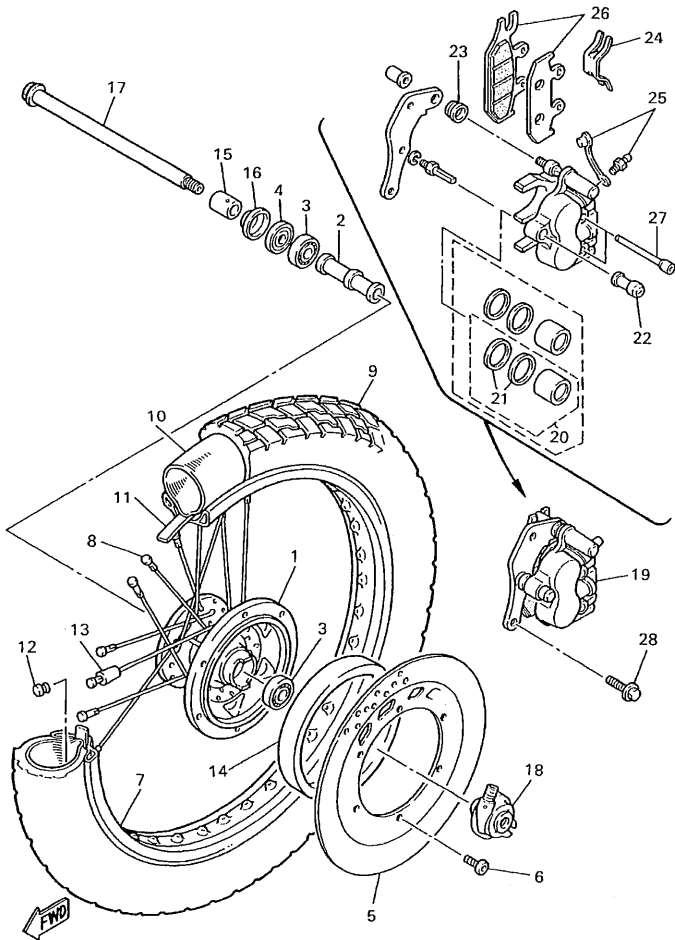

4PT351-5260

FIG. 28 FRONT WHEEL

REF. NO.	PART NO.	DESCRIPTION	4PT7	4SL4	REMARKS
26	4PT-W0045-00	.BRAKE PAD KIT	1	1	
27	3TB-25933-00	.PIN, PAD	2	2	
28	90105-10778	BOLT, WASHER BASED	2	2	
-----					
-----					
-----					
-----					
-----					
-----					

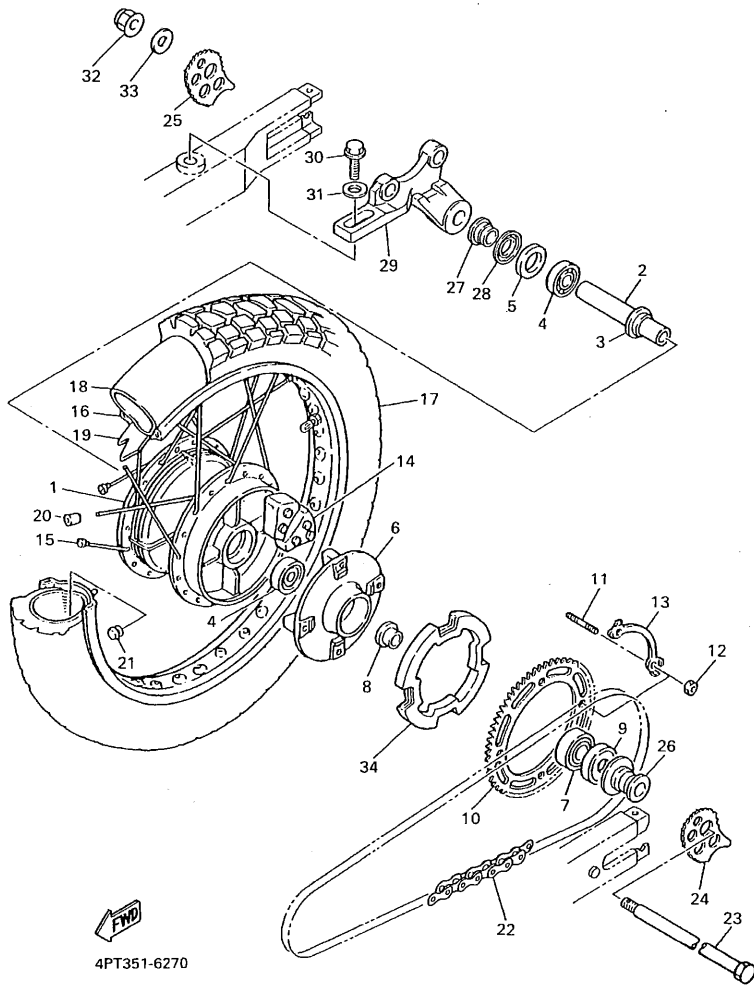
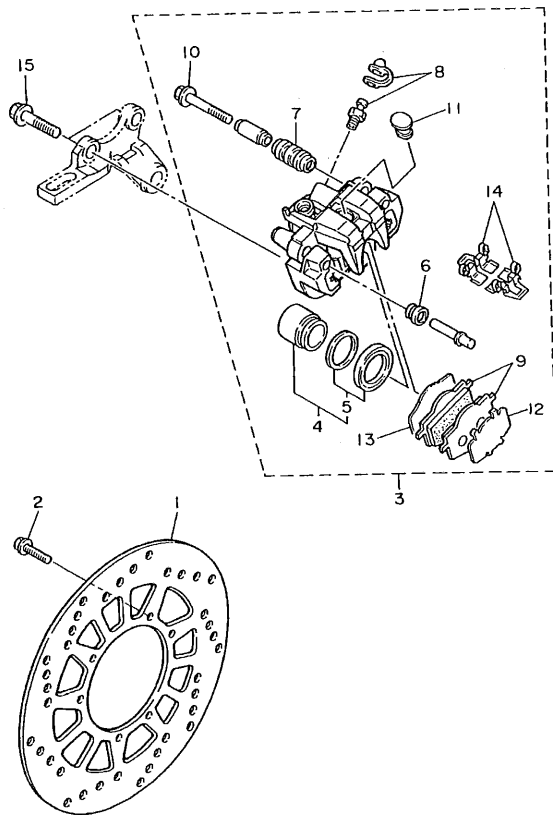

FIG. 29 REAR WHEEL

REF. NO.	PART NO.	DESCRIPTION	4PT7	4SL4	REMARKS
1	2KF-25311-00-98	HUB, REAR	1	1	LGB
2	90387-173M5	COLLAR	1	1	
3	146-25315-00	FLANGE, SPACER	1	1	
4	93306-20310	BEARING (B6203DU)	2	2	
5	93102-25311	OIL SEAL (FPJ 25-44-8 TS)	1	1	
6	1VJ-25366-01-98	CLUTCH, HUB	1	1	LGB
7	93306-30416	BEARING (B6304RS)	1	1	
8	1VJ-25377-00	COLLAR, WHEEL	1	1	
9	93106-30029	OIL SEAL	1	1	
10	4DN-25445-20	SPROCKET, DRIVEN (45T)	1	1	
11	90116-10348	BOLT, STUD	4	4	
12	90170-10219	NUT	4	4	
13	5Y1-25412-00	WASHER	2	2	
14	5Y1-25364-00	DAMPER	4	4	
15	3TB-25304-00	SPOKE SET, REAR	1	1	
16	94425-17491	RIM (2.50-17)	1	1	
17	94112-1708D	TIRE (MCS 120/90-17 64S TW48)	1	1	UR BRIDGESTONE
	94112-1709S	TIRE (120/90-17 64S TRAILMAX)	1	1	UR DUNLOP
18	94212-17264	TUBE (MCS 120/90-17 TR-4)	1	1	UR BRIDGESTONE
	94212-17281	TUBE (120/90.130/80-17)	1	1	UR DUNLOP
19	94330-17158	BAND, RIM (3.00-17)	1	1	BRIDGESTONE
20	156-25398-00	BALANCER, WHEEL	1	1	UN
21	90338-09130	PLUG	1	1	
22	94581-45106	CHAIN (DID520V2-106LE)	1	1	
23	3AJ-25381-01	AXLE, WHEEL	1	1	
24	3Y1-25388-01	PULLER, CHAIN 1	1	1	
25	3Y1-25389-00	PULLER, CHAIN 2	1	1	





3TB351-0280

FIG. 30 REAR BRAKE CALIPER

REF. NO.	PART NO.	DESCRIPTION	4PT7	4SL4			REMARKS
1	2KF-25831-50	DISC, BRAKE	1	1			
2	90109-065G4	BOLT	6	6			
3	3TB-2580W-10	CALIPER ASSY, REAR 2	1	1			
4	2KF-W0057-00	.PISTON ASSY, CALIPER	1	1			
5	34X-W0047-00	..CALIPER SEAL KIT	1	1			
6	5R2-25937-00	.BOOT 2	1	1			
7	34X-25937-00	.BOOT 2	1	1			
8	51L-W0048-00	.BLEED SCREW KIT	1	1			
9	34X-W0046-02	.BRAKE PAD KIT 2	1	1			
10	2GV-25926-00	.BOLT	1	1			
11	34X-25845-00	.CAP, INDICATOR	1	1			
12	3TB-25827-00	.SHIM, CALIPER	1	1			
13	2KF-25828-00	.SHIM, CALIPER	1	1			
14	4MA-25919-00	.SUPPORT, PAD	2	2			
15	90105-10638	BOLT, WASHER BASED	2	2			

FIG. 31 STEERING HANDLE. CABLE

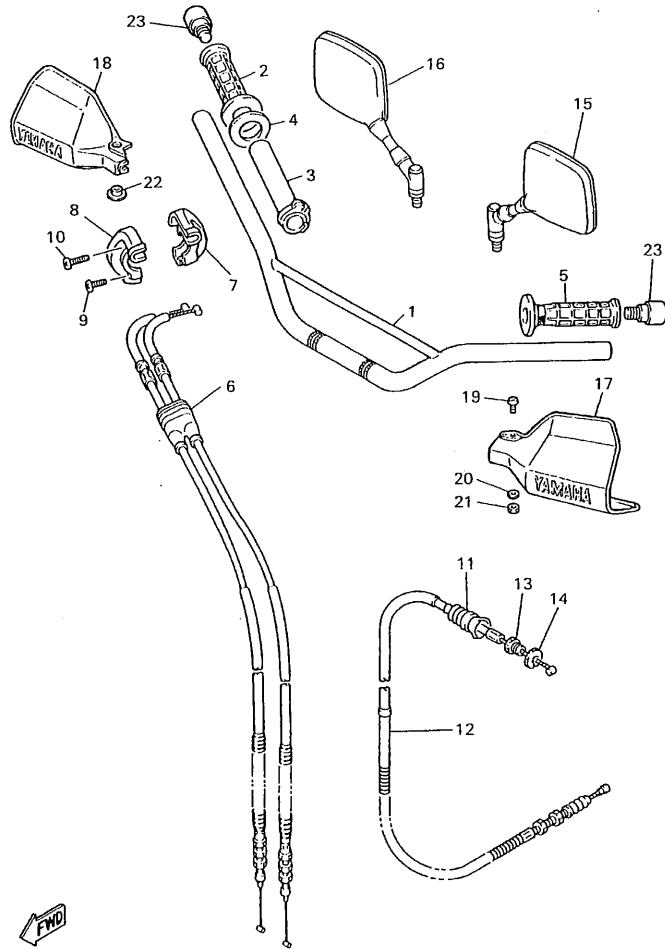

4PT351-6290

REF. NO.	PART NO.	DESCRIPTION	4PT7	4SL4			REMARKS
1	4PT-26111-00	HANDLEBAR	1	1			
2	55V-26242-00	GRIP (RIGHT)	1	1			
3	1RF-26243-00	TUBE, THROTTLE GUIDE	1	1			
4	3Y1-26249-00	RING, LEAF	1	1			
5	55V-26241-00	GRIP (LEFT)	1	1			
6	4PT-26302-00	THROTTLE CABLE ASSY	1	1			
7	34K-26281-00	CAP, GRIP UPPER	1	1			
8	1VJ-26282-00	CAP, GRIP LOWER	1	1			
9	98507-05020	SCREW, PAN HEAD	1	1			
10	98507-05025	SCREW, PAN HEAD	1	1			
11	1E6-26342-00	BOOT, CABLE	1	1			
12	4PT-26335-00	CABLE, CLUTCH	1	1			
13	90123-08046	BOLT	1	1			
14	90179-08148	NUT	1	1			
15	3TB-26280-00	REAR VIEW MIRROR ASSY(LEFT)	1	1			
16	3TB-26290-00	REAR VIEW MIRROR ASSY(RIGHT)	1	1			
17	3BN-26141-20	GUARD, BRUSH 1	1	1			UR PWS1
	2KF-26141-00	GUARD, BRUSH 1	1	1			UR YB
18	3TB-26142-60	GUARD, BRUSH 2	1	1			UR PWS1
	3TB-26142-70	GUARD, BRUSH 2	1	1			UR YB
19	98507-06030	SCREW, PAN HEAD	1	1			
20	92907-06600	WASHER, PLATE	1	1			
21	95307-06800	NUT	1	1			
22	90387-06500	COLLAR	1	1			
23	4PT-26246-00	END, GRIP	2	2			

FIG. 32 FRONT MASTER CYLINDER

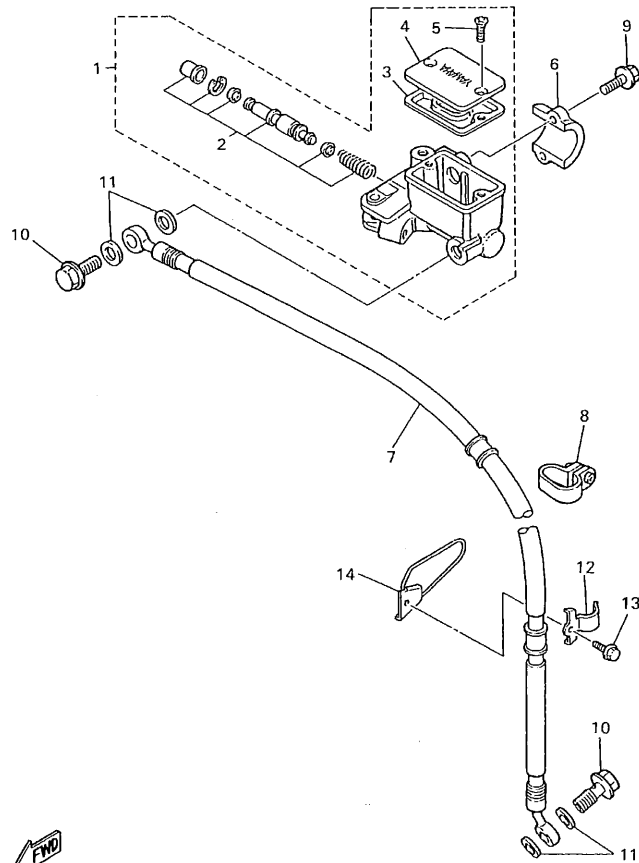

4PT351-5300

REF. NO.	PART NO.	DESCRIPTION	4PT7	4SL4	REMARKS
1	3TB-25870-00	MASTER CYLINDER SUB ASSY	1	1	
2	3TB-W0041-00	.CYLINDER KIT, MASTER	1	1	
3	4L0-25854-00	.DIAPHRAGM, RESERVOIR	1	1	
4	4H7-25852-00	.CAP, RESERVOIR	1	1	
5	98706-04012	.SCREW, FLAT HEAD	2	2	
6	4L0-25867-00	BRACKET, MASTER CYLINDER	1	1	
7	3TB-25872-02	HOSE, BRAKE 1	1	1	
8	3TB-23466-01	CLAMP	1	1	
9	95027-06025	BOLT, FLANGE	2	2	
10	90401-10159	BOLT, UNION	2	2	
11	90201-10118	WASHER, PLATE	4	4	
12	90461-16124	CLAMP	1	1	
13	95807-06016	BOLT, FLANGE	1	1	
14	3TB-23318-00	HOLDER, CABLE 1	1	1	

FIG. 33 STAND, FOOTREST

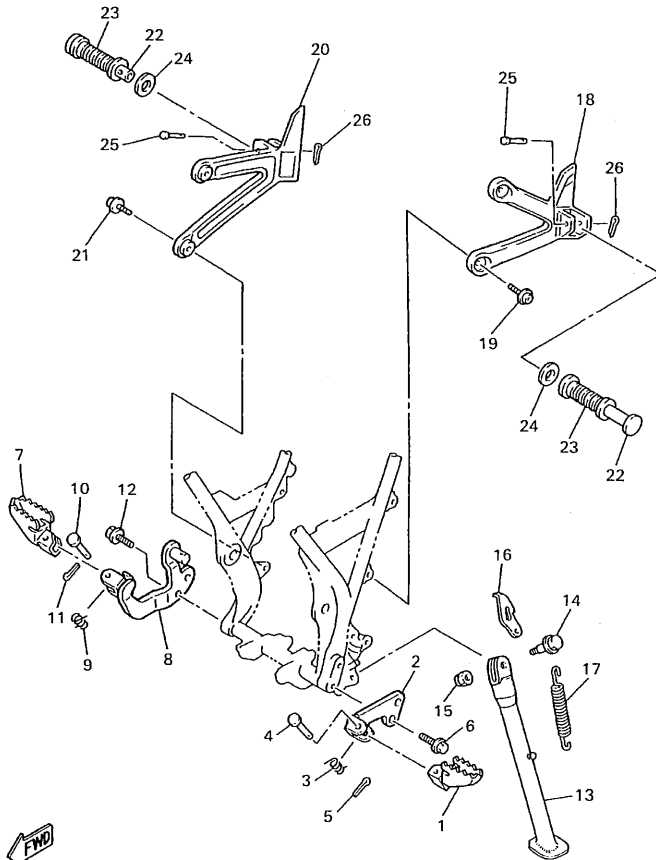

  
4PT351-5310

REF. NO.	PART NO.	DESCRIPTION			REMARKS
			4PT7	4SL4	
1	5Y1-27411-00-90	FOOTREST 1	1	1	ZK
2	34L-27412-00-R4	BRACKET, FOOTREST 1	1	1	HPB
3	90508-20023	SPRING, TORSION	1	1	
4	90240-08096	PIN, CLEVIS	1	1	
5	91401-25015	PIN, COTTER	1	1	
6	90105-10285	BOLT, WASHER BASED	2	2	
7	5Y1-27421-00-90	FOOTREST 2	1	1	ZK
8	2KF-27422-00-R4	BRACKET, FOOTREST 2	1	1	HPB
9	90508-20023	SPRING, TORSION	1	1	
10	90240-08096	PIN, CLEVIS	1	1	
11	91401-25015	PIN, COTTER	1	1	
12	90105-10285	BOLT, WASHER BASED	2	2	
13	4PT-27311-00	STAND, SIDE	1	1	
14	90105-12616	BOLT, WASHER BASED	1	1	
15	90185-12119	NUT, SELF-LOCKING	1	1	
16	5Y1-27315-00	LINK, SIDE STAND	1	1	
17	90507-32020	SPRING, TENSION	1	1	
18	4PT-2741L-00	BRACKET 4	1	1	
19	90109-087F1	BOLT	2	2	
20	4PT-2742L-00	BRACKET 5	1	1	
21	90109-087F1	BOLT	2	2	
22	120-27431-00	FOOTREST, REAR 1	2	2	
23	120-27433-00	COVER, REAR FOOTREST	2	2	
24	90201-20279	WASHER, PLATE	2	2	
25	91701-06040	PIN, CLEVIS	2	2	
26	91401-20012	PIN, COTTER	2	2	



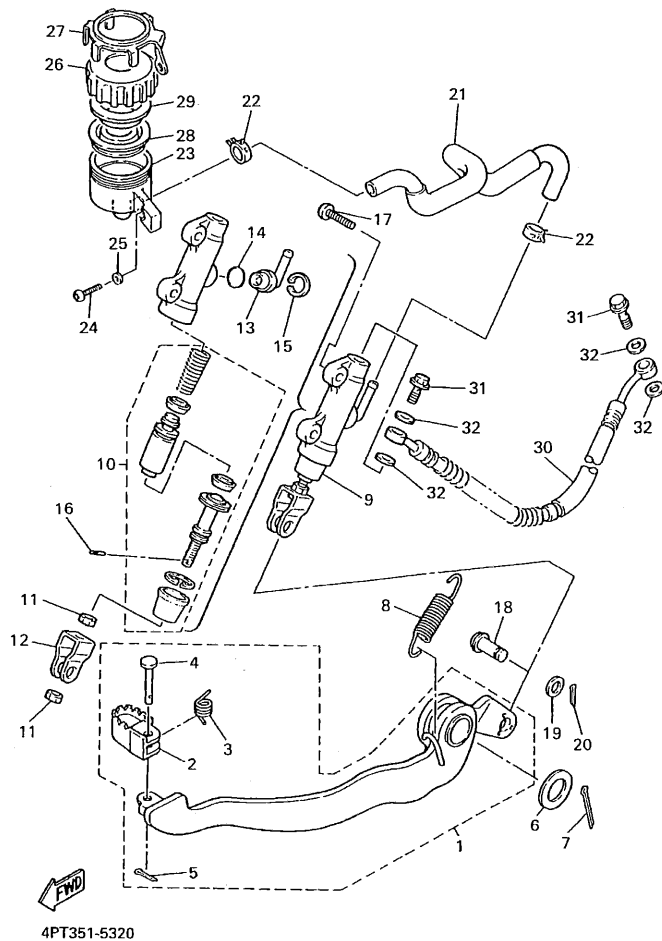

FIG. 34 REAR MASTER CYLINDER

REF. NO.	PART NO.	DESCRIPTION			REMARKS
			4PT7	4SL4	
1	3TB-27200-02	PEDAL, BRAKE	1	1	
2	55V-27242-00	.PEDAL, BRAKE	1	1	
3	90508-14352	.SPRING, TORSION	1	1	
4	91701-06022	.PIN, CLEVIS	1	1	
5	91401-20012	.PIN, COTTER	1	1	
6	90201-14215	WASHER, PLATE	1	1	
7	91401-30020	PIN, COTTER	1	1	
8	90507-18055	SPRING, TENSION	1	1	
9	4PT-2580E-00	REAR MASTER CYLINDER ASSY	1	1	
10	4BA-W0042-50	.CYLINDER KIT, MASTER	1	1	
11	95302-08600	.NUT	2	2	
12	2YK-27222-00	.JOINT	1	1	
13	2YK-2582A-00	.JOINT	1	1	
14	93210-15620	.O-RING	1	1	
15	2VN-25866-00	.CIRCLIP	1	1	
16	3KW-27234-00	.PIN, BRAKE ROD	1	1	
17	92017-08020	BOLT, BUTTON HEAD	2	2	
18	90240-08124	PIN, CLEVIS	1	1	
19	90201-08083	WASHER, PLATE	1	1	
20	91401-16012	PIN, COTTER	1	1	
21	4PT-25895-00	HOSE, RÉSERVOIR	1	1	
22	90467-14057	CLIP	2	2	
23	47X-25894-00	TANK, RESERVOIR	1	1	
24	98507-06020	SCREW, PAN HEAD	1	1	
25	92907-06600	WASHER, PLATE	1	1	
26	2KF-25852-50	CAP, RÉSERVOIR	1	1	
27	3AJ-25888-00	COVER, RESERVOIR TANK	1	1	

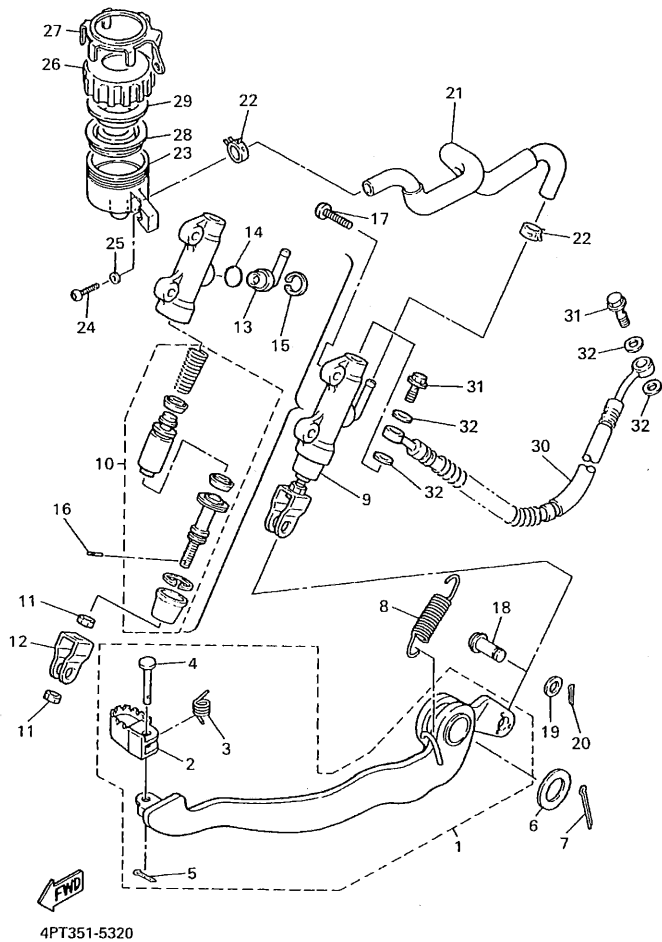
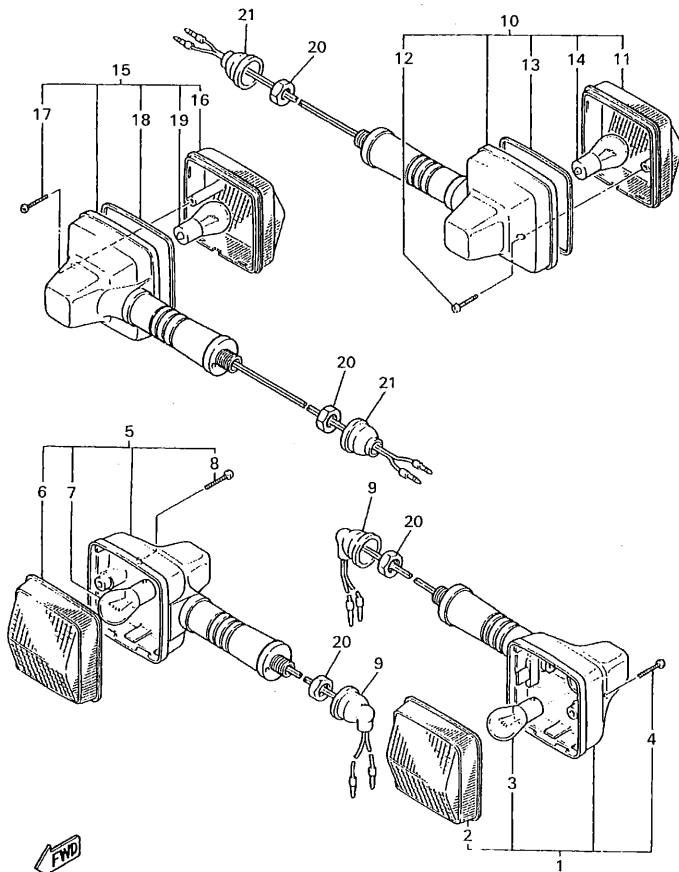

FIG. 34 REAR MASTER CYLINDER

REF. NO.	PART NO.	DESCRIPTION	4PT7	4SL4	REMARKS
28	360-25854-01	DIAPHRAGM, RESERVOIR	1	1	
29	2GU-25855-00	BUSH, DIAPHRAGM	1	1	
30	4PT-25873-10	HOSE, BRAKE 2	1	1	
31	90401-10159	BOLT, UNION	2	2	
32	90201-10118	WASHER, PLATE	4	4	
-----					
-----					
-----					
-----					
-----					
-----					
-----					
-----					







4PT351-5350

FIG. 37 FLASHER LIGHT

REF. NO.	PART NO.	DESCRIPTION	4PT7	4SL4	REMARKS
1	3TB-83310-01	FRONT FLASHER LIGHT ASSY 1	1	1	
2	47J-83312-00	.LENS, FLASHER	1	1	
3	306-83311-40	.BULB, FLASHER (12V-21W)	1	1	
4	97706-40620	.SCREW, TAPPING	1	1	
5	3TB-83320-01	FRONT FLASHER LIGHT ASSY 2	1	1	
6	47J-83322-00	.LENS, FLASHER 2	1	1	
7	306-83311-40	.BULB, FLASHER (12V-21W)	1	1	
8	97706-40620	.SCREW, TAPPING	1	1	
9	18G-83365-00	CAP	2	2	
10	4PT-83330-00	REAR FLASHER LIGHT ASSY 1	1	1	
11	2KF-83332-00	.LENS, FLASHER	1	1	
12	97706-40620	.SCREW, TAPPING	1	1	
13	47J-83313-00	.GASKET, FLASHER LENS	1	1	
14	306-83311-40	.BULB, FLASHER (12V-21W)	1	1	
15	4PT-83340-00	FLASHER LIGHT ASSY 2	1	1	
16	2KF-83342-00	.LENS, FLASHER 2	1	1	
17	97706-40620	.SCREW, TAPPING	1	1	
18	47J-83313-00	.GASKET, FLASHER LENS	1	1	
19	306-83311-40	.BULB, FLASHER (12V-21W)	1	1	
20	95307-12700	NUT	4	4	
21	10V-83365-00	CAP	2	2	

FIG. 38 METER

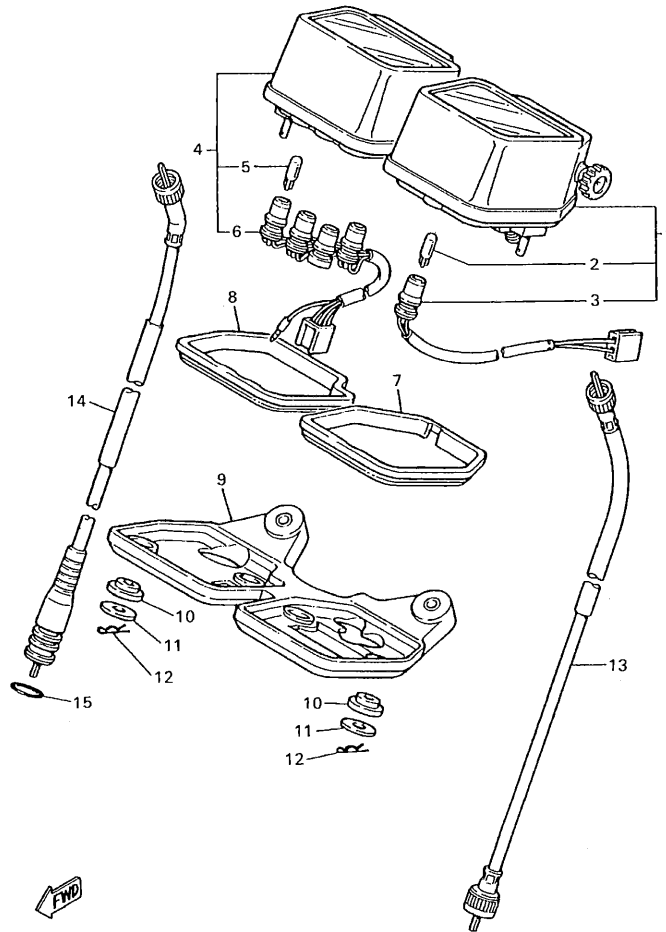

4PT351-5360

REF. NO.	PART NO.	DESCRIPTION	4PT7	4SL4	REMARKS
1	34L-83570-F1	SPEEDOMETER ASSY	1	1	
	43F-83570-G1	SPEEDOMETER ASSY	1		FOR GBR
2	37T-83517-00	.BULB (12V-3.4W)	1	1	
3	5Y1-83536-00	.SOCKET, METER	1	1	
4	1VJ-83540-41	TACHOMETER ASSY	1	1	
5	37T-83517-00	.BULB (12V-3.4W)	4	4	
6	30X-83520-00	.SOCKET CORD ASSY	1	1	
7	5Y1-83513-00	DAMPER	1	1	
8	5Y1-83541-00	DAMPER	1	1	
9	5Y1-83519-00	BRACKET, METER	1	1	
10	1M1-83526-00	DAMPER 2	4	4	
11	90201-05033	WASHER, PLATE	4	4	
12	437-83525-00	CLIP	4	4	
13	3ET-83550-02	SPEEDOMETER CABLE ASSY	1	1	
14	4PT-83560-00	TACHOMETER CABLE ASSY	1	1	
15	93210-14104	O-RING	1	1	

FIG. 39 HEADLIGHT

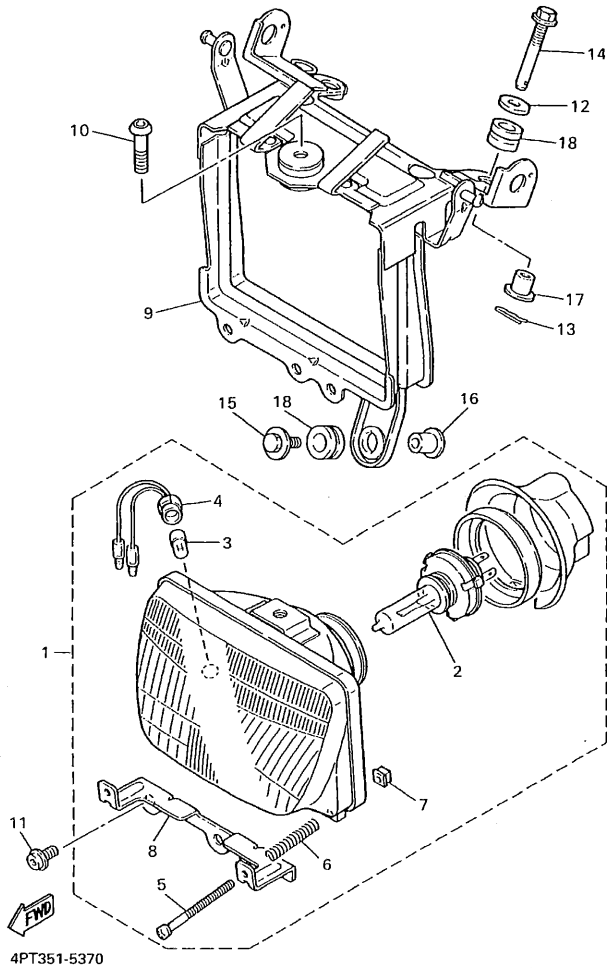

REF. NO.	PART NO.	DESCRIPTION	4PT7	4SL4	REMARKS
1	3TB-84320-10	LENS ASSY	1	1	
	3TB-84320-20	LENS ASSY	1		FOR GBR
2	2F9-84314-00	.BULB (12V-60/55W)	1	1	(H4)HALOGEN
3	4E2-84347-00	.BULB (12V-4W)	1	1	
	306-84347-30	.BULB (12V 3.4W)	1		FOR GBR
4	3TB-84312-00	.HOLDER, SOCKET	1	1	
5	3TB-84325-00	.SCREW, RIM FITTING	2	2	
6	5G2-84332-60	.SPRING, SCREW	2	2	
7	198-84334-60	.NUT, ADJUSTING	2	2	
8	3TB-8431R-00	.STAY, SETTING	1	1	
9	4PT-84311-01	BODY, HEADLIGHT	1	1	
10	92017-08025	BOLT, BUTTON HEAD	1	1	
11	3TB-84329-00	BOLT, WING 1	2	2	
12	90202-06013	WASHER, PLATE	2	2	
13	90468-12120	CLIP	2	2	
14	3TB-84137-00	BOLT, SPECIAL	2	2	
15	90119-06097	BOLT, WITH WASHER	1	1	
16	90387-063E6	COLLAR	1	1	
17	90387-07391	COLLAR	2	2	
18	90480-14102	GROMMET	3	3	





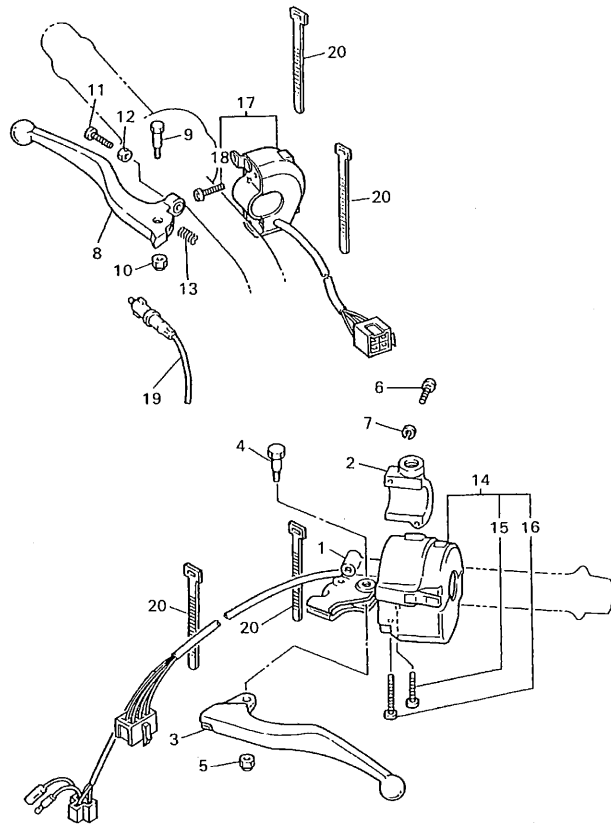

4PT351-5390

FIG. 41 HANDLE SWITCH. LEVER

REF. NO.	PART NO.	DESCRIPTION	4PT7	4SL4	REMARKS
1	1LN-82911-00	HOLDER, LEVER 1	1	1	
2	33G-82913-01	HOLDER, LEVER LOWER 1	1	1	
3	3FY-83912-01	LEVER 1	1	1	
4	90109-06799	BOLT	1	1	
5	95607-06100	NUT, U	1	1	
6	98507-05020	SCREW, PAN HEAD	2	2	
7	92907-05100	WASHER, SPRING	2	2	
8	3YR-83922-00	LEVER 2	1	1	
9	90109-062A8	BOLT	1	1	
10	95607-06100	NUT, U	1	1	
11	90149-06131	SCREW	1	1	
12	90170-06010	NUT	1	1	
13	90501-10312	SPRING, COMPRESSION	1	1	
14	4MY-83969-00	SWITCH, HANDLE 5	1	1	
15	98506-05030	.SCREW, PAN HEAD	1	1	
16	98506-05040	.SCREW, PAN HEAD	1	1	
17	4DW-83975-00	SWITCH, HANDLE 2	1	1	
18	98507-05018	.SCREW, PAN HEAD	2	2	
19	3WP-83980-00	FRONT STOP SWITCH ASSY	1	1	
20	437-83936-01	BAND, SWITCH CORD	4	4	

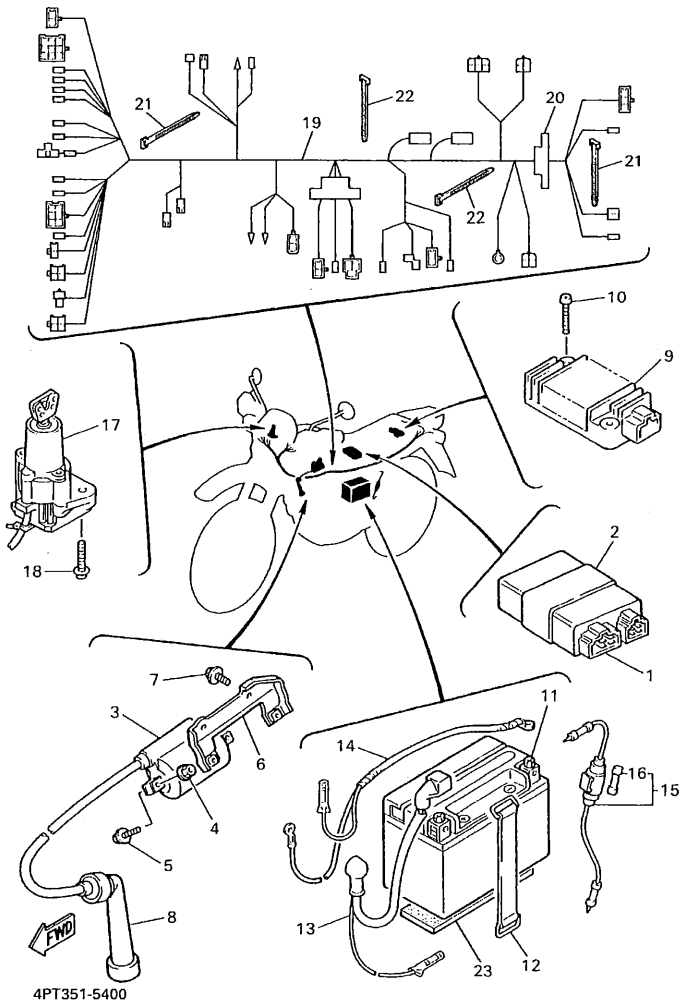
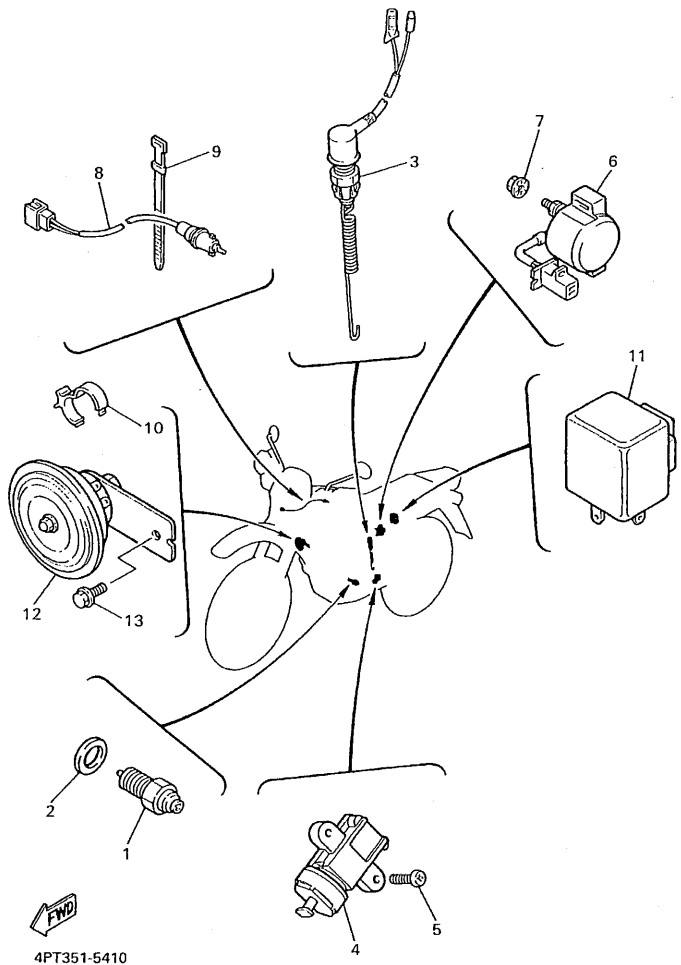

FIG. 42 ELECTRICAL 1

REF. NO.	PART NO.	DESCRIPTION	4PT7	4SL4	REMARKS
1	4PT-82305-01	IGNITOR UNIT ASSY	1		
	3TB-82305-10	IGNITOR UNIT ASSY		1	
2	4FL-85546-00	BAND	1	1	
3	3SX-82310-00	IGNITION COIL ASSY	1	1	
4	90179-05523	NUT	2	2	
5	97007-05025	BOLT	2	2	
6	3TB-82316-01	BRACKET, IGNITION COIL	1	1	
7	95807-06010	BOLT, FLANGE	2	2	
8	371-82370-00	PLUG CAP ASSY	1	1	
9	3TJ-81960-02	RECTIFIER & REGULATOR ASSY	1	1	
10	98507-06025	SCREW, PAN HEAD	2	2	
11	3PK-82100-01	BATTERY ASSY (YTX9-BS 12V-8AH)	1	1	
12	2T4-82131-00	BAND, BATTERY	1	1	
13	4PT-82115-00	WIRE, PLUS LEAD	1	1	
14	4PT-82116-00	WIRE, MINUS LEAD	1	1	
15	2UJ-82150-02	FUSE HOLDER ASSY	1	1	
16	148-82151-00	.FUSE (20A)	1	1	
17	4PU-82501-00	MAIN SWITCH STEERING LOCK	1	1	
18	90109-080G5	BOLT	2	2	
19	4PT-82590-00	WIRE HARNESS ASSY	1	1	
20	8Y0-82599-00	COVER, CONNECTER	1	1	
21	5A8-82591-00	BAND	2	2	
22	90465-13152	CLAMP	2	2	
23	5Y1-82122-00	SEAT, BATTERY	1	1	

FIG. 43 ELECTRICAL 2



REF. NO.	PART NO.	DESCRIPTION	4PT7	4SL4	REMARKS
1	4GY-82540-10	NEUTRAL SWITCH ASSY	1	1	
2	90430-10148	GASKET	1	1	
3	34L-82530-02	STOP SWITCH ASSY	1	1	
4	3LD-82566-40	SWITCH, SIDE STAND	1	1	
5	98507-05016	SCREW, PAN HEAD	2	2	
6	3AY-81940-00	STARTER RELAY ASSY	1	1	
7	95707-06500	NUT, FLANGE	2	2	
8	2NT-82917-00	SWITCH	1	1	
9	447-82591-00	BAND	1	1	
10	90464-25217	CLAMP	1	1	
11	34L-83350-20	FLASHER RELAY ASSY	1	1	
12	34Y-83371-00	HORN	1	1	
13	95027-06010	BOLT, FLANGE	1	1	

NUMERICAL INDEX

PARTNO.	GRID NO.	PARTNO.	GRID NO.	PARTNO.	GRID NO.	PARTNO.	GRID NO.	PARTNO.	GRID NO.	PARTNO.	GRID NO.
3TB-W0041-00	E - 9	2F3-12117-00	B - 7	5Y1-14149-00	C - 5	1JK-14357-00	C - 4	5Y1-14572-00	C - 4	3YF-16351-00	C - 11
4BA-W0042-50	E - 11	1J7-12118-00	B - 7	5Y1-14159-00	C - 3	30X-14358-00	C - 2	4PT-14611-00	C - 6	4HT-16356-01	C - 11
4PT-W0045-00	E - 4	1J7-12119-01	B - 7		C - 5		C - 4	3YF-14613-01	C - 6	4PT-16371-00	C - 11
34X-W0046-02	E - 7	1VJ-12121-00	B - 7	7KF-14162-00	C - 3	5Y1-14358-00	C - 2	3YF-14628-00	C - 6	3JD-16382-00	C - 11
3GD-W0047-00	E - 3	2NX-12146-00	B - 7		C - 5		C - 4	4PT-14711-10	C - 6	5Y1-16383-00	C - 11
34X-W0047-00	E - 7	34K-12151-00	B - 7	1VJ-14197-00	C - 2	2WJ-14367-00	C - 5	3TB-14728-00	C - 6	34K-17121-01	C - 13
1UY-W0048-50	E - 3	2NX-12156-00	B - 7		C - 5	5Y1-14384-00	C - 2	4PT-14752-00	C - 6	1VJ-17131-00	C - 13
51L-W0048-00	E - 7	2NX-12159-00	B - 7	3LD-14197-00	C - 4		C - 4	3YF-14755-00	C - 6	34K-17141-00	C - 13
2KF-W0057-00	E - 7	34K-12161-00	B - 7	3TD-14197-00	C - 3	2JN-14385-00	C - 2	4BD-14766-00	C - 6	3YF-17151-01	C - 13
3TB-W0057-00	E - 3	34K-12162-00	B - 7	5Y1-14198-00	C - 2		C - 4	1JK-1490A-00	C - 3	3AJ-17211-00	C - 13
1VJ-W1141-00	B - 5	34K-12163-00	B - 7		C - 4	689-14386-00	C - 2		C - 5	2JT-17221-00	C - 13
5Y1-W1343-00	B - 9	2NX-12166-00	B - 7	5Y1-14216-00	C - 2		C - 4	2KF-1490J-00	C - 5	1VJ-17231-00	C - 13
3TB-W2147-00-WL	D - 3	1JK-12170-00	B - 8		C - 4	3TB-1441A-00	B - 11	3UX-1490J-10	C - 5	3AJ-17241-00	C - 13
4PT-W2834-50	E - 13	3TB-12176-00	B - 8	7KF-14227-00	C - 2		B - 14	4PT-1490J-00	C - 3	3YF-17251-01	C - 13
4PT-W2834-60	E - 13	3TB-12210-00	B - 8		C - 4	3TB-1441E-00	B - 12	4PT-1490J-10	C - 3	3YF-17401-00	C - 13
4PT-Y2343-00	D - 11	4DW-12213-00	B - 8	1VJ-14286-00	C - 3		B - 14	3GV-1490K-00	C - 3	3YF-17402-00	C - 13
3TB-11101-02	B - 2	34K-12231-00	B - 8		C - 5	3UX-1441L-01	B - 15		C - 5	3YF-17439-00	C - 13
583-11127-00	B - 2	34K-12241-00	B - 8	4PT-14291-00	C - 2	3TB-14411-01	B - 11	1JK-14940-01	C - 2	2NX-17460-01	C - 13
	B - 4	583-13113-00	B - 9		C - 4		B - 14		C - 4	5Y1-17471-00	C - 13
4H7-11133-10	B - 2	3AJ-13161-01	B - 9	2JN-14293-00	C - 2	3TB-14412-00	B - 14	4PT-15100-11	C - 7	1JK-17800-01	B - 2
34K-11145-00	B - 6	3AJ-13300-01	B - 9		C - 4	4PT-14412-00	B - 11	3Y6-15144-00	C - 7	5Y1-18101-02	D - 2
3TB-11166-00	C - 7	3AJ-13325-00	B - 9	3UX-14301-03	C - 4	5Y1-14419-00	B - 12	3YF-15167-00	C - 7	43F-18102-02	D - 2
2KF-11181-01	B - 4	3SX-13329-00	B - 9	4PT-14301-01	C - 2		B - 15	3Y6-15167-00	C - 7	1VJ-18110-01	D - 2
1L9-11186-00	B - 2	4DW-13415-00	B - 9	3UX-14303-00	B - 15	34X-1443E-00	B - 12	5Y1-15383-00	C - 7	1W6-18113-00	D - 2
5Y1-11187-00	B - 2	4X7-13440-01	B - 9	1JK-14313-55	C - 3		B - 15	4PT-15411-00	C - 8	34K-18120-00	D - 2
214-11198-01	B - 9	4PT-13447-00	B - 9		C - 5	4PT-14431-00	B - 11	4PT-15415-00	C - 8	4PT-18140-00	C - 15
4PT-1131E-00	B - 4	3TB-13464-00	B - 10	14T-14323-00	C - 2	43G-14436-00	B - 11	4PT-15421-00	C - 8	4PT-18175-00	C - 15
3TB-11310-00	B - 4	4PT-13465-00	B - 10		C - 4		B - 14	5Y1-15427-01	B - 9	4PT-18511-00	C - 15
1VJ-11351-00	B - 4	16G-13569-00	B - 11	2KF-14341-00	C - 4	4PT-14437-00	B - 11	4PT-15431-10	C - 8	4PT-18512-00	C - 15
3TB-11400-00	B - 5		B - 14		C - 5	2WJ-14445-01	B - 15	3YF-15441-00	C - 8	4PT-18513-00	C - 15
34K-11454-00	B - 5	4PT-13581-00	B - 11	43F-14342-23	C - 3	4PT-14451-01	B - 11	4DW-15451-00	C - 8	3YF-18531-00	C - 15
5Y1-11496-01	B - 5	4PT-13586-00	B - 11		C - 5		B - 14	4DW-15455-00	C - 9	3XV-18535-00	C - 15
5Y1-11531-00	B - 5	43F-13586-01	B - 14	288-14343-60	C - 3	3TB-14452-00	B - 12	4DW-15462-00	C - 8	3YF-18540-00	C - 15
2JT-11536-00	B - 5	1VJ-13596-00	B - 14	288-14343-61	C - 5		B - 15	1VJ-15511-00	C - 10	136-18542-00	C - 15
34K-11565-02	B - 5	4PT-13596-00	B - 11	288-14343-63	C - 5	3TB-14453-00	B - 11	1VJ-15512-00	C - 10	4PT-21110-01-WL	D - 3
34L-11610-00	B - 5	2KF-1410A-00	C - 3	288-14343-65	C - 3		B - 14	3YF-15515-00	C - 10	4R8-21308-00	E - 2
34L-11610-20	B - 5		C - 5		C - 5	3TB-14454-00	B - 11	1VJ-15517-00	C - 10	34L-21315-00	D - 3
34L-11610-40	B - 5	2NX-14103-00	C - 3	288-14343-70	C - 3		B - 14	1VJ-15521-00	C - 10	3TB-21316-00-90	D - 3
3TB-11631-00-YO	B - 5		C - 5	30X-14343-55	C - 5	3TB-14457-00	B - 11	1VJ-15522-00	C - 10	4PT-2137W-01	D - 14
1JK-11633-01	B - 5	51Y-14105-00	C - 3	30X-14343-60	C - 3		B - 14	3TB-15590-01	C - 10	4PT-2137W-20	D - 14
3TB-11636-00	B - 5		C - 5	2WJ-14349-00	C - 5	3YF-14462-00	B - 12	3TB-15594-00	C - 10	4PT-2137X-01	D - 14
3TB-11638-00	B - 5	2JN-14107-00	C - 3	5Y1-14349-00	C - 3	4PT-14462-00	B - 13	3AJ-16111-00	C - 11	4PT-2137X-20	D - 14
3TB-11651-00	B - 5		C - 5		C - 5		B - 15	3AJ-16150-00	C - 11	3TB-2137Y-00	D - 15
1VJ-11681-00	B - 5	1JK-14131-01	C - 4	2KF-14355-00	C - 3	55K-14476-00	B - 12	2JN-16154-00	C - 11	46X-21376-00	D - 7
1VJ-12111-00	B - 7	1XL-14131-00	C - 2		C - 5		B - 14	5Y1-16321-00	C - 11	34M-2139X-00	D - 15
5Y1-12113-00	B - 7	30X-14148-00	C - 3	5Y1-14356-00	C - 2	5Y1-14536-00	C - 2	360-16325-00	C - 11	5Y1-21441-00	D - 3
5Y1-12114-00	B - 7		C - 5		C - 4		C - 4	5Y1-16331-01	C - 11	34K-21485-00	D - 3
4H7-12116-00	B - 7	5Y1-14149-00	C - 3	1JK-14357-00	C - 2	5Y1-14572-00	C - 2	3YF-16340-01	C - 11	34K-21486-00	D - 3

NUMERICAL INDEX

PARTNO.	GRID NO.	PARTNO.	GRID NO.	PARTNO.	GRID NO.	PARTNO.	GRID NO.	PARTNO.	GRID NO.	PARTNO.	GRID NO.
3RW-21511-60	D-5	4V4-22184-00	D-3	5A8-23434-01	D-11	4PT-25336-00	E-3	3BN-26141-20	E-8	3AJ-81850-00	C-10
3RW-21511-70	D-5		D-4	1E6-23441-10-98	D-11	5Y1-25364-00	E-5	3TB-26142-60	E-8	4G0-81871-00	C-10
3TB-21511-60	D-5	3TB-22189-00	D-9	3Y6-23442-00-98	D-11	1VJ-25366-01-98	E-5	3TB-26142-70	E-8	3AY-81940-00	F-7
3TB-21511-70	D-5	38V-22199-00	D-8	3TB-23466-01	E-9	36R-25367-00	E-6	55V-26241-00	E-8	3TB-81953-00	B-11
3TB-21521-01	D-5	4PT-22210-00-33	D-10	4PT-24110-10-06	D-14	1VJ-25377-00	E-5	55V-26242-00	E-8		B-14
4PT-21569-50	D-5	34L-22216-00	D-10	4PT-24110-10-07	D-14	3AJ-25381-01	E-5	1RF-26243-00	E-8	3TJ-81960-02	F-6
4PT-21569-60	D-5	34L-22226-01	D-10	4PT-2414H-00	D-15	1VJ-25383-00	E-6	4PT-26246-00	E-8	3PK-82100-01	F-6
4PT-21611-00	D-5	3TB-22311-00	D-9	4PT-2414J-00	D-15	3Y1-25388-01	E-5	3Y1-26249-00	E-8	4PT-82115-00	F-6
4PT-21611-10	D-5	4PT-23102-00	D-12	4PT-2416F-00	D-15	3Y1-25389-00	E-5	3TB-26280-00	E-8	4PT-82116-00	F-6
1VJ-21621-00	D-6	4PT-23103-00	D-12	4PT-2416F-10	D-15	4PT-2539F-00	E-6	34K-26281-00	E-8	5Y1-82122-00	F-6
3TB-21621-00	B-12	4PT-23110-00	D-12	4PT-2416G-00	D-15	156-25398-00	E-3	1VJ-26282-00	E-8	2T4-82131-00	F-6
	B-15	3EN-23111-50	D-12	4PT-24161-20	D-15		E-5	3TB-26290-00	E-8	2UJ-82150-02	F-6
4PT-2163A-00	D-5		D-13	4PT-24161-40	D-15	5Y1-25412-00	E-5	4PT-26302-00	E-8	148-82151-00	F-6
42U-21639-00	D-5	4PT-23118-00	D-12	4PT-24162-20	D-15	4DN-25445-20	E-5	4PT-26335-00	E-8	3TB-82305-10	F-6
3TB-2164F-01	D-6		D-13	4PT-24162-40	D-15	4PT-2580E-00	E-11	1E6-26342-00	E-8	4PT-82305-01	F-6
2KF-21685-01	D-5	3JD-23125-L0	D-12	3TB-24181-00	D-14	4PT-2580T-00	E-3	1UJ-27114-00	C-6	3SX-82310-00	F-6
2KF-21685-11	D-5	4PT-23126-00	D-12	4PT-24182-00	D-14	3TB-2580W-10	E-7	3TB-27200-02	E-11	3PK-82316-01	F-6
34X-21691-00	B-12	2KF-23127-01	D-13	30X-24183-01	D-14	2KF-25819-00	E-6	2YK-27222-00	E-11	371-82370-00	F-6
	B-15	4PT-23136-00	D-12	30X-24186-01	D-14	2YK-2582A-00	E-11	3KW-27234-00	E-11	4PU-82501-00	F-6
4PT-21711-00	D-7	4PT-23141-00	D-12	3TB-24188-00	D-14	3LP-2582T-00	E-3	55V-27242-00	E-11	34L-82530-02	F-7
4PT-21711-10	D-7		D-13	4PT-24240-50	D-14	3TB-25827-00	E-7	4PT-27311-00	E-10	4GY-82540-10	F-7
4PT-21717-00	D-7	43F-23144-10	D-12	4PT-24240-60	D-14	2KF-25828-00	E-7	5Y1-27315-00	E-10	3LD-82566-40	F-7
4PT-21721-00	D-7	3BN-23145-00	D-12	4PT-24246-50	D-14	2KF-25831-50	E-7	4PT-2741L-00	E-10	4PT-82590-00	F-6
4PT-21721-10	D-7	36Y-23146-10	D-12	4PT-24246-60	D-14	34X-25845-00	E-7	5Y1-27411-00-90	E-10	447-82591-00	F-7
4PT-2173E-50	D-7	4DW-23149-40	D-12	4PT-24247-50	D-15	2KF-25852-50	E-11	34L-27412-00-R4	E-10	5A8-82591-00	F-6
4PT-2173E-60	D-7		D-13	4PT-24247-60	D-15	4H7-25852-00	E-9	4PT-2742L-00	E-10	4PT-82599-00	F-6
4PT-2174A-00	D-7	26H-23156-00	D-12	3FY-24500-00	D-14	360-25854-01	E-12	5Y1-27421-00-90	E-10	1LN-82911-00	F-5
4PT-2174A-10	D-7	509-23158-L0	D-12	360-24512-00	C-2	4L0-25854-00	E-9	2KF-27422-00-R4	E-10	33G-82913-01	F-5
4PT-2174A-20	D-7		D-13		C-4	2GU-25855-00	E-12	120-27431-00	E-10	2NT-82917-00	F-7
4PT-2174L-50	D-7	3XJ-23167-L0	D-13	4X8-24512-00	D-14	2VN-25866-00	E-11	120-27433-00	E-10	3TB-83310-01	E-15
4PT-2174L-60	D-7	4PT-23170-00	D-12	3AJ-24523-00	D-14	4L0-25867-00	E-9	2KF-27491-00	D-9	306-83311-40	E-15
4PT-2174T-00	D-6		D-13	3AJ-24534-00	D-14	3TB-25870-00	E-9	3TB-28100-00	D-7	47J-83312-00	E-15
3TB-21756-00	D-3	3JD-23171-L0	D-12	214-24535-00	C-2	3TB-25872-02	E-9	4PT-28217-00	E-13	47J-83313-00	E-15
3TB-21771-00	D-4	3GM-23173-00	D-12		C-4	4PT-25873-10	E-12	4PT-28365-00	E-13	3TB-83320-01	E-15
8V7-21961-00	E-13		D-13	11H-24602-03	D-14	4PT-25876-00	D-9	4PT-28390-50	E-13	47J-83322-00	E-15
4PT-22110-00-35	D-8	278-23181-50	D-12	3TB-24723-00	E-2	3AJ-25888-00	E-11	4PT-28390-60	E-13	4PT-83330-00	E-15
34L-22117-00	D-9		D-13	4PT-24731-30	E-2	47X-25894-00	E-11	3TB-28415-01	D-4	2KF-83332-00	E-15
1VJ-22123-00	D-8	43F-23188-10	D-12	4PT-24731-40	E-2	4PT-25895-00	E-11	89A-77214-00	B-13	4PT-83340-00	E-15
2K6-22128-01	D-8		D-13	4PT-24770-30	E-2	3JD-25917-00	E-3		B-15	2KF-83342-00	E-15
34L-22128-00	D-8	3TB-23191-11	D-13	4PT-24770-40	E-2	3TB-25919-00	E-3	3TB-81410-01	E-14	34L-83350-20	F-7
23X-22129-00	D-9	43M-23192-L0	D-13	3TB-25104-00	E-3	4MA-25919-00	E-7	3TB-81450-01	E-14	10V-83365-00	E-15
34L-22129-00	D-10	3TB-2331E-00	D-11	3YF-25111-00-98	E-3	2GV-25926-00	E-7	3TB-81800-01	C-10	18G-83365-00	E-15
1VJ-22141-00	D-9	3LD-23318-00	D-11	322-25118-00	E-3	3TB-25933-00	E-4	3AJ-81801-00	C-10	34Y-83371-00	F-7
4PT-22151-00	D-8	3TB-23318-00	E-9	55U-25181-01	E-3	1UY-25937-51	E-3	3AJ-81809-00	C-10	5Y1-83513-00	F-2
3TB-2217A-00	D-8	4PT-23340-00	D-13	34L-25190-01	E-3	34X-25937-00	E-7	3AJ-81820-00	C-10	37T-83517-00	F-2
34L-2217F-00	D-8	4PT-23389-10	D-11	3TB-25304-00	E-5	5R2-25937-00	E-7	3AJ-81830-00	C-10	5Y1-83519-00	F-2
3TB-22178-00	D-3	1W1-23416-00	D-11	2KF-25311-00-98	E-5	4PT-26111-00	E-8	11H-81844-00	C-10	30X-83520-00	F-2
30X-22178-00	D-4	3YF-23418-00	D-11	146-25315-00	E-5	2KF-26141-00	E-8	1FK-81847-00	C-10	437-83525-00	F-2

NUMERICAL INDEX

PARTNO.	GRID NO.	PARTNO.	GRID NO.	PARTNO.	GRID NO.	PARTNO.	GRID NO.	PARTNO.	GRID NO.	PARTNO.	GRID NO.
1M1-83526-00	F-2	90105-12668	D-8	90179-05523	D-15	90201-303P4	C-10	90387-066M3	D-5	90464-25217	F-7
5Y1-83536-00	F-2	90109-062A8	F-5		F-6	90202-05193	D-14	90387-066B1	D-5	90465-08125	B-15
1VJ-83540-41	F-2	90109-063E8	B-7	90179-06668	C-6	90202-06013	F-3	90387-06737	D-8		B-2
5Y1-83541-00	F-2	90109-063E9	B-2	90179-08148	E-8	90202-26142	D-11	90387-07391	D-3	90465-08344	C-7
3ET-83550-02	F-2	90109-06418	B-3	90179-10201	B-4	90206-06090	C-6		F-3	90465-13152	F-6
4PT-83560-00	F-2		C-11	90179-10279	B-4	90206-12075	B-7		F-4	90467-09006	D-14
34L-83570-F1	F-2	90109-06419	B-9	90179-14317	B-5	90209-22191	C-13	90387-075H4	B-12	90467-10008	D-4
43F-83570-G1	F-2	90109-065G4	E-7	90179-18552	C-14	90215-16242	B-6		B-15	90467-10039	B-11
3FY-83912-01	F-5	90109-06799	F-5	90179-25615	D-11	90215-20197	C-11	90387-07717	D-7		B-14
3YR-83922-00	F-5	90109-080G5	F-6	90185-10060	D-9	90215-20231	C-11	90387-07789	D-8	90467-11106	B-12
437-83936-01	F-5	90109-081F0	E-3	90185-12119	E-10	90215-23265	C-13	90387-085E1	D-4		B-15
4MY-83969-00	F-5	90109-082G0	C-6	90185-14070	D-9	90240-08096	E-10	90387-1206D	D-9	90467-12052	B-12
4DW-83975-00	F-5	90109-087F1	E-10	90201-047A2	B-12	90240-08124	E-11	90387-122J6	D-9		B-15
3WP-83980-00	F-5	90109-08705	D-4		B-15	90240-14106	D-10	90387-152J3	E-3	90467-14015	C-7
3TB-84137-00	F-3	90109-102G8	D-9	90201-05033	F-2	90267-32071	D-5	90387-16782	C-7	90467-14057	E-11
3TB-8431R-00	F-3	90110-08193	E-14	90201-06055	D-7	90267-40075	B-11	90387-173M5	E-5	90467-17128	C-7
4PT-84311-01	F-3	90116-06475	B-2	90201-064H0	D-6		B-14	90387-174F0	E-6	90468-12120	F-3
3TB-84312-00	F-3	90116-10263	C-7	90201-06557	D-5	90267-40077	B-12	90387-17783	C-7	90480-01141	D-7
2F9-84314-00	F-3	90116-10348	E-5	90201-080L8	B-4		B-15	90401-08133	B-9	90480-12053	E-13
3TB-84320-10	F-3	90116-10378	B-2	90201-08083	E-11	90267-40080	D-3	90401-10159	E-12	90480-12325	B-11
3TB-84320-20	F-3	90116-10506	C-7	90201-08326	C-6	90267-40110	D-6		E-9		B-14
3TB-84325-00	F-3	90119-06060	D-5	90201-085L3	B-4	90280-16053	B-5	90430-05126	B-9	90480-13398	D-6
3TB-84329-00	F-3	90119-06063	E-2	90201-08753	D-3	90282-05013	B-6	90430-06014	B-3	90480-13428	D-15
5G2-84332-60	F-3	90119-06097	D-5		D-4	90282-07042	C-11		C-11	90480-14102	F-3
198-84334-60	F-3		F-3	90201-10118	E-12	90338-06143	D-8	90430-08119	C-7	90480-14329	B-12
2XJ-84345-00	B-11	90119-06228	D-5		E-9	90338-08174	B-12		D-3		B-15
	B-12		D-9	90201-10119	C-11		B-15	90430-08143	C-8	90480-15064	B-12
306-84347-30	F-3	90123-08046	E-8	90201-10124	B-4	90338-09130	E-3	90430-08178	B-4		B-15
4E2-84347-00	F-3	90149-05110	B-9	90201-10140	E-6		E-5		C-7	90480-15363	D-3
34X-84527-00	F-4	90149-05299	D-15	90201-10141	D-11	90338-22207	B-3	90430-08204	B-9	90501-043E0	B-9
1XL-84710-E0	F-4	90149-06131	F-5	90201-102J5	C-6	90340-08014	C-8	90430-10148	F-7	90501-10312	F-5
1A2-84714-41	F-4	90149-06154	E-2	90201-10430	D-9	90340-14068	B-2	90430-22123	D-3	90501-22721	B-5
3TB-84717-01	F-4	90149-06223	D-15	90201-10590	B-4	90340-14132	B-9	90430-27124	D-4	90501-23142	C-11
53V-84721-40	F-4		D-7	90201-120A5	D-8	90340-36076	C-8	90445-10458	D-14	90507-18055	E-11
34Y-84723-E0	F-4	90149-06263	E-13	90201-12474	D-2	90380-14095	D-8	90445-115J7	D-4	90507-32020	E-10
3YF-84751-00	D-6	90149-08067	C-7	90201-12699	D-9	90380-14130	D-10	90445-122H1	B-12	90508-14352	E-11
3Y6-85130-02	D-6	90151-06017	C-15	90201-13409	D-4	90380-22111	D-8		B-15	90508-14767	C-11
33G-85132-02	D-6	90159-06078	C-15	90201-140G9	D-8	90386-20120	D-8	90450-21082	B-11	90508-20023	E-10
4FL-85546-00	F-6	90159-06092	C-11	90201-14215	E-11	90386-20123	D-9	90450-22017	B-10	90508-26691	C-15
90101-12295	D-10	90170-06010	F-5	90201-14226	B-5	90387-06026	D-7	90460-46206	B-11	90508-29629	D-2
90101-12498	D-9	90170-06128	B-7	90201-150U6	C-11	90387-06033	B-12		B-14	90560-15240	E-3
90105-07342	B-8	90170-10219	E-5	90201-15238	D-9		B-15	90460-51059	B-12	90560-20199	C-14
90105-08505	B-4	90170-16343	B-6	90201-15785	C-11	90387-062E2	D-14		B-15	91317-06012	C-6
90105-10186	C-6	90170-20274	C-11	90201-20276	C-13	90387-063E6	F-3	90460-58124	B-12	91317-06016	B-10
90105-10285	E-10	90170-20327	C-11	90201-20279	E-10	90387-06372	D-5		B-15		C-8
90105-10638	E-7	90176-06065	D-5	90201-244A8	D-8	90387-064J1	D-15	90461-16124	E-9	91317-06018	B-2
90105-10778	E-4	90176-08028	B-4	90201-251F6	D-9		D-5	90462-16102	C-8	91317-06020	B-11
90105-12616	E-10	90176-22050	D-11	90201-301F4	B-5	90387-06500	E-8	90462-20217	B-3		B-14

NUMERICAL INDEX

PARTNO.	GRID NO.	PARTNO.	GRID NO.	PARTNO.	GRID NO.	PARTNO.	GRID NO.	PARTNO.	GRID NO.	PARTNO.	GRID NO.
91317-06025	B- 2	92907-06600	B- 8	93310-212R6	C- 10	95307-06600	D- 6	98501-04010	C- 2	99530-12016	C- 8
	B- 8		D- 8	93310-217R7	C- 10	95307-06800	E- 8		C- 3	99530-14016	C- 7
	C- 8		E- 11	93310-530C7	C- 10	95307-12700	E- 15		C- 4		
	C- 9		E- 8	93310-635D4	B- 5	95604-16200	E- 6		C- 5		
91317-06030	C- 7	92907-10600	D- 3	93315-10838	C- 12	95607-04100	D- 6	98501-04014	C- 2		
	C- 8	92907-14600	D- 10	93315-22251	D- 8	95607-06100	D- 5		C- 4		
91317-06035	B- 4	92907-16200	E- 6	93315-31502	C- 12		F- 5	98501-05010	C- 3		
	B- 9	92990-04100	C- 2	93315-31750	D- 8	95607-10100	D- 11		C- 5		
	C- 8		C- 4	93316-00501	C- 15	95617-10200	D- 3	98506-04016	D- 13		
91317-06040	B- 2	92990-06200	C- 6	93332-00001	D- 11	95617-12100	D- 10	98506-05030	F- 5		
91317-06045	C- 7	93101-14092	C- 8	93332-00008	D- 11		D- 8	98506-05040	F- 5		
91317-06050	B- 2	93101-25106	B- 6	93340-21505	C- 11		D- 9	98507-04012	D- 6		
	C- 8	93102-12106	D- 2	93440-11024	C- 10	95701-08500	D- 13	98507-05016	E- 14		
91317-06055	B- 2	93102-15212	C- 11	93440-12052	B- 2	95707-05500	D- 6		F- 7		
91317-06060	C- 7	93102-20281	E- 3	93440-25084	C- 13	95707-06500	F- 4	98507-05018	F- 5		
	D- 8	93102-25226	C- 13	93450-24028	B- 5		F- 7	98507-05020	B- 12		
91317-06080	B- 9	93102-25311	E- 5	93503-08007	B- 9	95807-06010	D- 9		B- 14		
91317-06115	B- 2	93106-22019	D- 8	93604-10011	C- 15		F- 6		D- 11		
91317-06125	B- 2	93106-30029	E- 5	93605-10090	B- 5	95807-06012	D- 9		E- 8		
91401-16012	E- 11	93108-35004	D- 8	93608-33046	D- 2	95807-06016	D- 14		F- 5		
91401-20012	E- 10	93210-07135	B- 9	93700-06004	D- 9		D- 8	98507-05025	E- 8		
	E- 11		C- 7	93700-06005	D- 9		E- 9	98507-06012	C- 8		
91401-25015	E- 10	93210-08521	B- 7	94109-2108C	E- 3	95807-06020	B- 12	98507-06016	B- 9		
91401-30020	E- 11	93210-100A9	B- 10	94109-2109R	E- 3		B- 15	98507-06020	E- 11		
91401-30025	D- 10	93210-13361	B- 9	94112-1708D	E- 5	95807-08012	D- 3	98507-06025	E- 14		
91701-06022	E- 11		C- 8	94112-1708S	E- 5	95817-06030	C- 10		F- 6		
91701-06040	E- 10	93210-13657	B- 2	94209-21277	E- 3	95817-10070	D- 3	98507-06030	E- 8		
92014-06012	C- 6	93210-14104	F- 2	94212-17264	E- 5	95817-10100	D- 3	98580-04016	C- 2		
92017-08020	E- 11	93210-15171	B- 10	94212-17281	E- 5	95821-08055	D- 13		C- 4		
92017-08025	F- 3	93210-15620	E- 11	94227-21101	E- 3	95827-06025	B- 12	98706-04012	E- 9		
92017-08050	D- 6	93210-32172	B- 2	94330-17158	E- 5		B- 15	98707-06012	C- 7		
92902-04100	C- 2	93210-36510	C- 8	94330-21084	E- 3		D- 3	98707-06030	B- 2		
	C- 4	93210-36769	B- 11	94418-21492	E- 3	95827-08035	D- 11	98907-06020	D- 7		
92907-03200	D- 5		B- 14	94425-17491	E- 5	95827-10030	E- 6	98980-08010	C- 6		
92907-04200	B- 12	93210-62523	B- 2	94581-45106	E- 5	97007-05025	F- 6	99001-09600	D- 2		
	B- 15	93210-64297	B- 9	94590-27126	B- 8	97007-06020	D- 8	99001-10600	D- 2		
	D- 3	93210-98473	B- 4	94701-00241	B- 2	97007-06025	D- 5	99009-10400	C- 12		
	D- 6	93306-00426	C- 13	95027-06010	D- 3	97017-10080	D- 3	99009-11400	B- 9		
92907-04600	B- 11	93306-00431	C- 13		F- 7	97027-06014	C- 13	99009-20400	C- 13		
	B- 14	93306-20006	C- 10	95027-06012	D- 6	97027-06016	B- 8		C- 14		
92907-05100	E- 14	93306-20205	E- 3	95027-06016	D- 14		C- 7	99247-00080	D- 6		
	F- 5	93306-20310	E- 5		D- 5	97027-06020	D- 2	99510-08016	C- 7		
92907-05600	B- 12	93306-30416	E- 5	95027-06025	E- 9	97701-40630	F- 4	99530-08016	B- 4		
	B- 14	93306-30525	B- 5	95027-08016	D- 4	97706-40620	E- 15		C- 7		
	D- 11	93306-30534	B- 5	95027-08040	C- 6	97707-50520	B- 11		C- 8		
	E- 14	93306-30535	C- 13		D- 11		B- 12	99530-10116	B- 2		
92907-06100	E- 14	93306-30540	C- 13	95302-08600	E- 11		B- 14	99530-12016	B- 4		
92907-06600	B- 2	93306-30702	B- 5	95307-05600	D- 11	97801-03008	D- 14		C- 7		